

Features and Benefits

The WM-12 is a wall-mounted steel enclosure that provides up to eighteen fibre ports in a minimum of space. The WM-12 has an integral configurable panel that accepts up to six USO II modules.

Modules may be mixed for fibre, UTP, STP, and coax, making it the most versatile and compact wall mount enclosure for mixed media. Its design guarantees that all of the media will be protected and proper fibre bend radius is maintained.

- Up to 18 fibre ports
- Accepts up to 6 USO II modules
- Fully configurable using Molex Premise Networks' USO II modules
- Available with fully lockable steel doors when security is a primary concern.

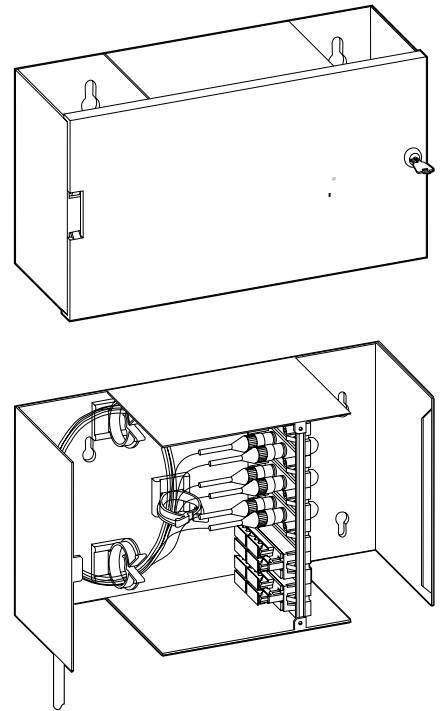

ORDERING INFORMATION

Order No.	SAP No.	Description
WFR-00018	Consult Molex	WM-12 - Graphite Grey
WFR-00020	Consult Molex	WM-12 - Champagne

MOLEX PREMISE NETWORKS

Americas
Tel: 630 969 4550
www.molexpn.com

EMEA
Tel: 44 (0)2392 205800
www.molexpn.co.uk

APAC
Tel: 61 3 9971 7111
www.molexpn.com.au