

# Art. 4842 .. 4845 Button expansion modules

## DESCRIPTION

Push button modules allow the expansion of the number of call buttons. Available in versions with 2, 3, 4 or 5 call push buttons. Each button has its own connection terminals, but the module can be configured to have a single common terminal for all buttons. The common terminals configuration can be selecting on the 4 jumpers, accessible from the rear of the module.

Depending on the number of push buttons available, the module can have 2 or 4 illumination LED's for the card name holder. Looking at the module from the front, push buttons are numbered as shown in the drawing. Each button has the relevant terminals: button 1-terminals **1,1C**, button 2-terminals **2,2C** etc.

## COMMON TERMINAL SETTING

Settings referred to the module with the maximum number of push buttons: Art. 4845 – 5 push buttons.

The settings shown are for all buttons common together to **1C** or all buttons individual, but you can choose any combination of this for each button.

## AVAILABLE VERSIONS

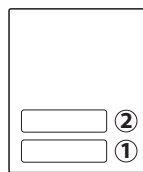

**Art. 4842**  
2 call button

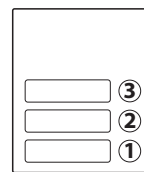

**Art. 4843**  
3 call button

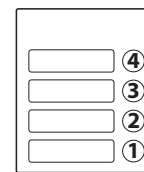

**Art. 4844**  
4 call button

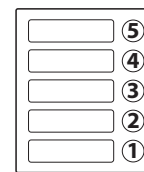

**Art. 4845**  
5 call button

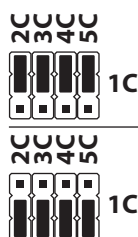

All push button common terminals are linked to common terminal **1C**.

Each button has its own common terminal.

## HOW TO REMOVE/INSERT THE CARD NAME HOLDER

- To avoid damage to the module front plate, mask the side that will be in contact with the screwdriver blade;
- Insert the screwdriver (flat side) into the card-holder hole as shown in **Fig. 1**;
- Move the screwdriver to the left as shown in **Fig. 2** to extract the card name holder;
- Edit the card name then replace it inside the holder and refit: insert the holder inside its housing from the left or right side then push the other side until it clips into place.

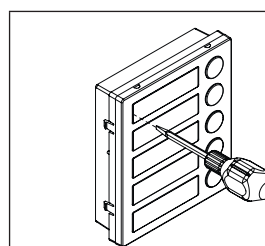

**Fig. 1**

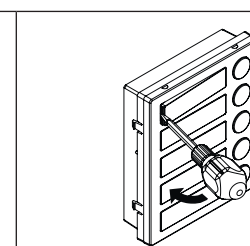

**Fig. 2**

## ADHESIVE GASKET PLACEMENT

Apply the **(Y)** seal as shown in **Fig. 3**.

## ANTI-TAMPERING LOCKS FIXING

Fit the anti-tampering locks **(W)** as shown in **Fig. 4**.

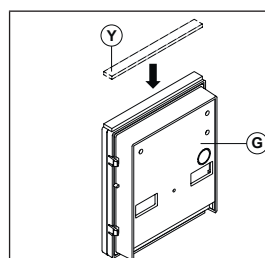

**Fig. 3**

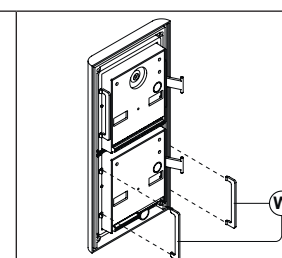

**Fig. 4**

## CONNECTION TERMINALS SIGNALS

-	12Vdc power input for illumination LED's supply
+	
<b>1C</b>	Push button 1 common
<b>1</b>	Push button 1
<b>2C</b>	Push button 2 common
<b>2</b>	Push button 2
<b>3C</b>	Push button 3 common
<b>3</b>	Push button 3
<b>4C</b>	Push button 4 common
<b>4</b>	Push button 4
<b>5C</b>	Push button 5 common
<b>5</b>	Push button 5

## TECHNICAL SPECIFICATIONS

<b>Power supply:</b>	12Vdc
<b>Power consumption:</b>	45mA max
<b>Working temperature:</b>	-20 +60 °C

## CLEANING OF THE PLATE

Use a clean and soft cloth. Use moderate warm water or non-aggressive cleansers.

### Do not use:

- abrasive liquids;
- chlorine-based liquids;
- metal cleaning products.

**Art. 4842 .. 4845** Moduli d'espansione pulsantiera**DESCRIZIONE**

I moduli pulsantiera permettono di espandere il numero di chiamate e sono disponibili in versione da 2, 3, 4 e 5 pulsanti.

Ciascun pulsante dispone del proprio morsetto comune, ma all'occorrenza il modulo può essere configurato per avere un solo morsetto comune. La configurazione avviene tramite i 4 jumper accessibili nella parte posteriore del modulo.

A seconda del numero di pulsanti presenti, il modulo può essere equipaggiato con 2 o 4 LED d'illuminazione cartellini. Guardando il modulo frontalmente, i pulsanti sono numerati come mostrato nel disegno. A ciascun pulsante corrispondono i relativi morsetti: pulsante 1 - morsetti **1,1C**, pulsante 2 - morsetti **2,2C** ecc.

**IMPOSTAZIONE COMUNE PULSANTI**

I settaggi si riferiscono al modulo col numero massimo di pulsanti: Art.4845 – 5 pulsanti di chiamata.

Le impostazioni mostrate sono relative alla configurazione contemporanea di tutti i pulsanti del modulo, ma è possibile scegliere singolarmente per ciascun pulsante se collegare il relativo morsetto comune al morsetto **1C**.

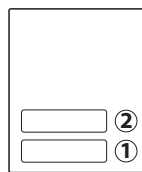
**VERSIONI DISPONIBILI**

**Art. 4842**  
2 pulsanti

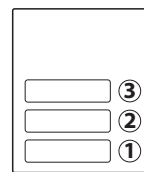

**Art. 4843**  
3 pulsanti

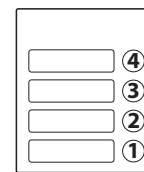

**Art. 4844**  
4 pulsanti

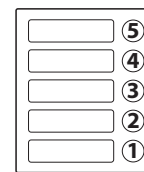

**Art. 4845**  
5 pulsanti



I comuni di tutti i pulsanti sono collegati al morsetto comune **1C**.

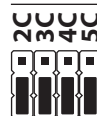

Ogni pulsante ha il proprio comune.

**RIMOZIONE/INSERIMENTO DEL PORTA-CARTELLINO**

- Per evitare ammaccature della placca frontale, proteggere il lato che verrà in contatto con la lama del cacciavite utilizzando una striscia di nastro isolante;
- Inserire il cacciavite (lato piatto della lama) nell'apposita fessura del porta cartellino come mostrato in **Fig. 1**;
- Fare leva con il cacciavite come mostrato in **Fig. 2** per rimuovere il porta-cartellino (fare attenzione a non ammaccare la placca);
- Modificare il cartellino e riporlo all'interno del porta-cartellino quindi riposizionare lo stesso al suo posto inserendolo nel suo alloggiamento dal lato destro o sinistro e premendo il lato rimasto libero fino all'aggancio (compiendo un movimento contrario a quello fatto per estrarlo).

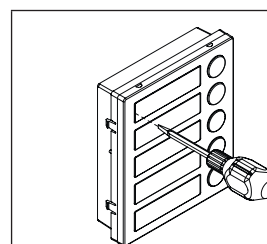

**Fig. 1**

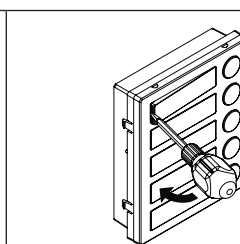

**Fig. 2**

**APPLICAZIONE GUARNIZIONE ADESIVA**

Applicare la guarnizione adesiva (Y) come mostrato in **Fig. 3**.

**INSERIMENTO FERMI ANTI-EFFRAZIONE**

Inserire i fermi anti-effrazione (W) come mostrato in **Fig. 4**.

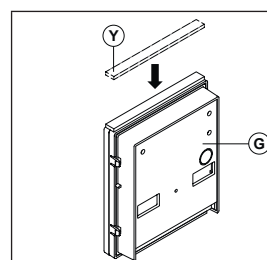

**Fig. 3**

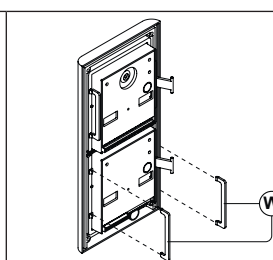

**Fig. 4**

**SEGNALI MORSETTERIA DI CONNESSIONE**

-	Ingresso 12Vdc per LED d'illuminazione cartellini
+	
<b>1C</b>	Comune pulsante 1
<b>1</b>	Pulsante 1
<b>2C</b>	Comune pulsante 2
<b>2</b>	Pulsante 2
<b>3C</b>	Comune pulsante 3
<b>3</b>	Pulsante 3
<b>4C</b>	Comune pulsante 4
<b>4</b>	Pulsante 4
<b>5C</b>	Comune pulsante 5
<b>5</b>	Pulsante 5

**SPECIFICHE TECNICHE**

**Tensione d'alimentazione:** 12Vdc

**Assorbimento:** 45mA max

**Temperatura di lavoro:** -20 +60 °C

**PULIZIA DELLA PLACCA**

Usare un panno morbido e pulito. Usare acqua tiepida o un detersivo non aggressivo.

**Non usare:**

- prodotti abrasivi;
- prodotti contenenti cloro;
- prodotti per la pulizia dei metalli.

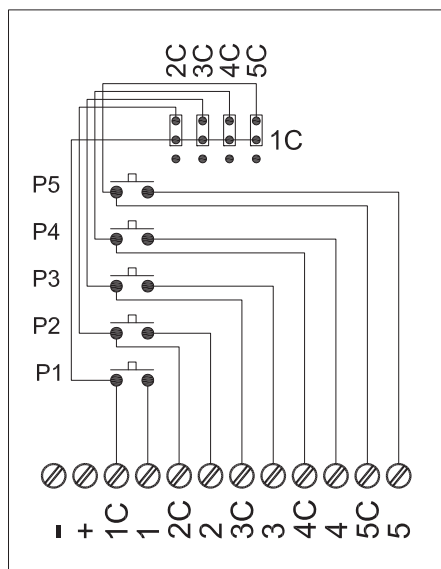

Push buttons internal connection  
Collegamento interno dei pulsanti

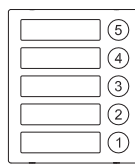

Art.4845

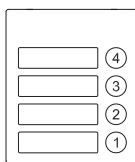

Art.4844

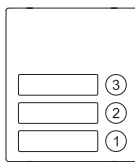

Art.4843

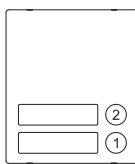

Art.4842

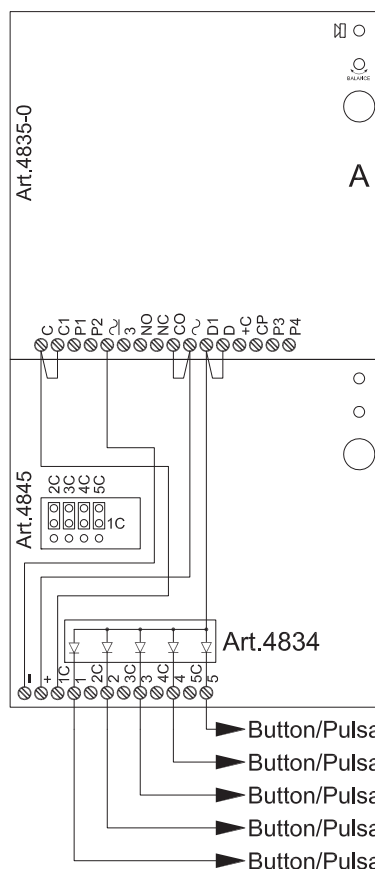

Example of connection with speakerunit Art.4835  
Esempio di collegamento con portiere elettrico Art.4835

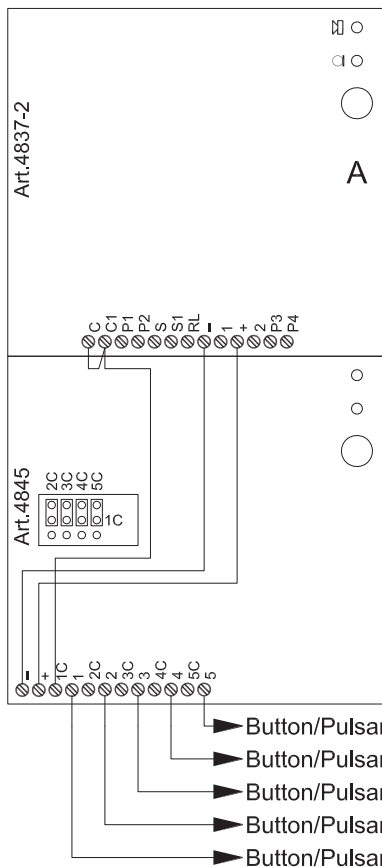

Example of connection with speaker unit Art.4837  
Esempio di collegamento con portiere elettrico Art.4837

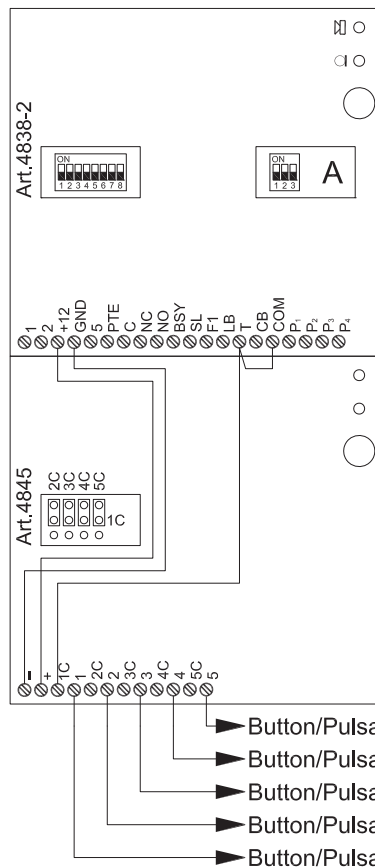

Example of connection with speakerunit Art.4838  
Esempio di collegamento con portiere elettrico Art.4838

Title: Button Expansion Modules 4842..4845 Connection

Collegamento moduli d'espansione pulsantiera 4842..4845

Videx Electronics S.p.A.  
Via del Lavoro 1, 63846 Monte Giberto (FM)  
Phone: +39 0734 631669 - Fax: +39 0734 631669  
www.videx.it - Info@videx.it

Notes:  
.  
Note:  
.

Data creazione: 10/06/2014  
Foglio 1 / 1

Data modif: 10/06/2014

Autore: Marco Rongoni  
Cod.Fil: 4842-4845 b.dwg

Blank page with horizontal dashed lines for writing.

Blank page with horizontal dashed lines for writing.

Blank page with horizontal dashed lines for writing.

## ENG DISPOSAL

In accordance with the Legislative Decree no. 49 of 14 March 2014 "Implementation of the Directive 2012/19/EU on waste electrical and electronic equipment (WEEE)".

The crossed-out bin symbol on the equipment or on the packaging indicates that when the product reaches the end of its lifetime, it must be collected separately from mixed municipal waste. The user must, therefore, dispose of the equipment at the end of its lifetime in the suitable waste collection centres or bring it to the retailer during the purchase of a new equipment of equivalent type at the ratio of one-to-one. Furthermore, the user is allowed to dispose of the WEEEs of very small size (domestic appliances without any external dimension exceeding 25 cm (9.84 inches) for free to the retailers, without any purchase obligation. The correct waste disposal of the WEEEs contributes to their reuse, recycling and recovery and avoids potential negative effects on the environment and human health due to the possible presence of dangerous substances within them.



## ITA SMALTIMENTO

Ai sensi del Decreto Legislativo 14 marzo 2014, n° 49 "Attuazione della direttiva 2012/19/UE sui rifiuti di apparecchiature elettriche ed elettroniche (RAEE)".

Il simbolo del cassonetto barrato riportato sull'apparecchiatura o sulla sua confezione indica che il prodotto alla fine della propria vita utile deve essere raccolto separatamente dagli altri rifiuti urbani misti. L'utente dovrà, pertanto, conferire l'apparecchiatura giunta a fine vita presso gli idonei centri di raccolta differenziata oppure riconsegnarla al rivenditore al momento dell'acquisto di una nuova apparecchiatura di tipo equivalente, in ragione di uno a uno. L'utente ha, inoltre, la possibilità di conferire gratuitamente presso i distributori, senza alcun obbligo di acquisto, per i RAEE di piccolissime dimensioni (per le apparecchiature di tipo domestico con nessuna dimensione esterna superiore a 25 cm).

L'adeguata raccolta differenziata dei RAEE contribuisce al loro riutilizzo, riciclaggio e recupero ed evita potenziali effetti negativi sull'ambiente e sulla salute umana dovuti alla eventuale presenza di sostanze pericolose al loro interno.

## FRA ÉLIMINATION

Conformément au décret législatif n° 49 du 14 mars 2014 relatif à l'« Application de la directive 2012/19 / UE relative aux déchets d'équipements électriques et électroniques (DEEE) ».

Le symbole de la poubelle barrée sur l'équipement ou sur son emballage indique que le produit en fin de vie utile doit être collecté séparément des autres déchets municipaux en mélange. L'utilisateur doit donc remettre l'équipement en fin de vie aux centres de collecte appropriés ou le restituer au revendeur lors de l'achat d'un nouveau type d'équipement équivalent, dans le rapport de un à un. De plus, l'utilisateur a la possibilité de conférer gratuitement aux distributeurs, sans aucune obligation d'achat, de très petits DEEE (pour les appareils ménagers sans dimensions extérieures supérieures à 25 cm). La collecte séparée adéquate des DEEE contribue à leur réutilisation, leur recyclage et leur valorisation et évite les éventuels effets négatifs sur l'environnement et la santé humaine en raison de la présence possible de substances dangereuses dans ceux-ci.

## SPA ELIMINACIÓN

De conformidad con el Decreto legislativo n. 49 de 14 de marzo 2014 "Aplicación de la Directiva 2012/19/UE relativa a residuos de aparatos eléctricos y electrónicos (RAEE)".

El símbolo del contenedor tachado indicado sobre los aparatos o sobre los embalajes señala que el producto al final de su vida útil debe ser recogido separadamente de otros residuos municipales mezclados. Por tanto, el usuario deberá conferir los aparatos al final de su vida útil en los apropiados centros de recogida selectiva o devolverlos al revendedor al momento de la compra de nuevos aparatos equivalentes, en una relación de uno a uno. Además, el usuario tiene la posibilidad de entregar sin cargo a los distribuidores, sin ninguna obligación de compra, los RAEEs muy pequeños (para electrodomésticos sin dimensiones externas superiores a 25 cm).

La recogida selectiva apropiada de los RAEEs contribuye a su reutilización, reciclaje y valorización y evita potenciales impactos negativos sobre el medio ambiente y la salud humana debidos a la posible presencia de sustancias peligrosas dentro de ellos.

## NLD VERWIJDERING

In overeenstemming met het Wetsbesluit nr. 49 van 14 maart 2015 "Implementatie van de Richtlijn 2012/19/EU inzake afgedankte elektrische en elektronische apparaten (AEEA)".

Het doorgekruiste vuilnisbaksymbool op het apparaat of de verpakking geeft aan dat het product aan het einde van zijn levensduur niet samen met het gewone huisvuil weggegooid mag worden. De gebruiker moet het apparaat aan het einde van zijn levensduur inleveren bij een gepast inzamelpunt of de winkel waar hij een nieuw apparaat van een gelijksoortig type zal kopen. De gebruiker kan tevens AEEA's van een zeer klein formaat (huishoudapparaten met een buitenafmeting kleiner dan 25 cm (9,84 inch) gratis en zonder enige aankoopverplichting bij handelaars inleveren. Een juiste verwijdering van AEEA's draagt bij tot hergebruik, recycling en terugwinning, en voorkomt potentiële negatieve effecten op het milieu en de menselijke gezondheid door de mogelijke aanwezigheid van gevaarlijke stoffen.

## POR ELIMINAÇÃO

De acordo com o Decreto Legislativo n.º 49 de 14 de março de 2014 "Implementação da Diretiva 2012/19/UE relativa aos resíduos de equipamentos elétricos e eletrónicos (REEE)".

O símbolo do caixote do lixo riscado no equipamento ou na embalagem indica que quando o produto atinge o fim da sua vida útil, deve ser recolhido separadamente dos resíduos urbanos mistos. O utilizador deve, portanto, eliminar o equipamento no final da sua vida útil nos centros de recolha de resíduos adequados ou levá-lo ao vendedor durante a compra de um novo equipamento de tipo equivalente, na proporção de um para um. Além disso, o utilizador pode eliminar gratuitamente os REEE de dimensões muito reduzidas aos vendedores, sem qualquer obrigação de compra. (só aparelhos domésticos sem qualquer dimensão externa que exceda 25 cm, ou seja 9,84 polegadas). A correta eliminação dos REEE contribui para a sua reutilização, reciclagem e recuperação e evita potenciais efeitos negativos sobre o ambiente e a saúde humana devido à possível presença de substâncias perigosas no seu interior.

<b>MANUFACTURER</b> <b>FABBRICANTE</b> <b>FABRICANT</b> <b>FABRICANTE</b> <b>FABRIKANT</b> <b>FABRICANTE</b> الشركة المصنعة	<b>VIDEX ELECTRONICS S.P.A.</b> Via del Lavoro, 1 63846 Monte Giberto (FM) Italy Tel (+39) 0734 631669 Fax (+39) 0734 632475 www.videx.it - info@videx.it	
<b>CUSTOMER SUPPORT</b> <b>SUPPORTO CLIENTI</b> <b>SUPPORTS CLIENTS</b> <b>ATENCIÓN AL CLIENTE</b> <b>KLANTENDIENST</b> <b>APOIO AO CLIENTE</b> خدمة العملاء	<b>VIDEX ELECTRONICS S.P.A.</b> www.videx.it - technical@videx.it Tel: +39 0734-631669 Fax: +39 0734-632475	UK Customers only: <b>VIDEX SECURITY LTD</b> www.videxuk.com Tech Line: 0191 224 3174 Fax: 0191 224 1559

*Main UK office:*  
**VIDEX SECURITY LTD**  
 1 Osprey Trinity Park  
 Trinity Way  
 LONDON E4 8TD  
 Phone: (+44) 0370 300 1240  
 Fax: (+44) 020 8523 5825  
 www.videxuk.com  
 marketing@videxuk.com

*Northern UK office:*  
**VIDEX SECURITY LTD**  
 Unit 4-7  
 Chillingham Industrial Estate  
 Chapman Street  
 NEWCASTLE UPON TYNE - NE6 2XX  
 Tech Line: (+44) 0191 224 3174  
 Phone: (+44) 0370 300 1240  
 Fax: (+44) 0191 224 1559

*Greece office:*  
**VIDEX HELLAS Electronics**  
 48 Filolaou Str.  
 11633 ATHENS  
 Phone: (+30) 210 7521028  
 (+30) 210 7521998  
 Fax: (+30) 210 7560712  
 www.videx.gr  
 videx@videx.gr

*Danish office:*  
**VIDEX DANMARK**  
 Hammershusgade 15  
 DK-2100 COPENHAGEN  
 Phone: (+45) 39 29 80 00  
 Fax: (+45) 39 27 77 75  
 www.videx.dk  
 videx@videx.dk

*Benelux office:*  
**NESTOR COMPANY NV**  
 E3 laan, 93  
 B-9800 Deinze  
 Phone: (+32) 9 380 40 20  
 Fax: (+32) 9 380 40 25  
 www.videx.be  
 info@videx.be

*Dutch office:*  
**NESTOR COMPANY BV**  
 Business Center Twente (BCT)  
 Grotestraat, 64  
 NL-7622 GM Borne  
 www.videxintercom.nl  
 info@videxintercom.nl



The product is CE marked demonstrating its conformity and is for distribution within all member states of the EU with no restrictions. This product follows the provisions of the European Directives 2014/30/EU (EMC); 2014/35/EU (LVD); 2011/65/EU (RoHS); CE marking 93/68/EEC.

Le produit est marqué CE à preuve de sa conformité et peut être distribué librement à l'intérieur des pays membres de l'union européenne UE.  
 Ce produit est conforme aux directives européennes 2014/30/EU (EMC) ; 2014/35/EU (LVD) ; 2011/65/EU (RoHS); marquage CE 93/68/EEC.

Het product heeft de CE-markering om de conformiteit ervan aan te tonen en is bestemd voor distributie binnen de lidstaten van de EU zonder beperkingen. Dit product volgt de bepalingen van de Europese Richtlijnen 2014/30/EU (EMC); 2014/35/EU (LVD); 2011/65/EU (RoHS); CE-markering 93/68/EEC.

يحمل المنتج علامة التوافق الأوروبي CE لإظهار توافقه مع المواصفات ذات الصلة وإمكانية توزيعه في كافة دول الاتحاد الأوروبي بدون أية قيود. يلبي هذا المنتج جميع متطلبات التوجيهات الأوروبية 2014/30/UE (EMC) ; 2014/35/UE (LVD) ; 2011/65/UE (RoHS) : علامة المطابقة للمواصفات الأوروبية CE 93/68/EEC.

Il prodotto è marchiato CE a dimostrazione della sua conformità e può essere distribuito liberamente all'interno dei paesi membri dell'Unione Europea UE.  
 Questo prodotto è conforme alle direttive Europee: 2014/30/UE (EMC); 2014/35/UE (LVD); 2011/65/UE (RoHS); marcatura CE 93/68/EEC.

El producto lleva la marca CE que demuestra su conformidad y puede ser distribuido en todos los estados miembros de la unión europea UE.  
 Este producto cumple con las Directivas Europeas 2014/30/EU (EMC); 2014/35/EU (LVD); 2011/65/EU (RoHS); marca CE 93/68/EEC.

O produto tem a marca CE que demonstra a sua conformidade e destina-se a distribuição em todos os estados membros da UE, sem restrições. Este produto segue as disposições das Diretivas Europeias 2014/30/UE (EMC); 2014/35/UE (LVD); 2011/65/UE (RoHS); marcação CE 93/68/EEC.

