

LDP3- 12- 24DC - Stikkmodul



2833770

El-nr.: 4315018

<https://www.phoenixcontact.com/no/produkter/2833770>

Vær oppmerksom på at dataene som er angitt i dette PDF-dokumentet genereres fra vår onlinekatalog. Du finner komplette data i brukerdokumentasjonen. De generelle bruksvilkårene for nedlastinger fra Internett gjelder.



Pluggmodul, med friløpsdiode og gul LED, polaritet **A1+**, **A2-**, inngangsspenning 12 ... 24 V
DC ± 20 %

Dine fordeler

- Mekanisk koding som beskytter mot feilplugging
- Demping av induktiv spolereturspenning

Forretningsinformasjon

Artikkelnummer	2833770
Pakkestørrelse	10 Stk.
Minimum bestillingsmengde	10 Stk.
Rabattgruppe	31BC63
Produkt nøkkel	CK6346
Katalogside	Side 392 (C-7-2015)
GTIN	4017918933968
Vekt pr. stk. (inkl. forpakning)	6,47 g
Vekt pr. stk. (ekskl. forpakning)	6,29 g
Tolltariffnummer	85366990
Opprinnelsesland	CN

LDP3- 12- 24DC - Stikkmodul



2833770

El-nr.: 4315018

<https://www.phoenixcontact.com/no/produkter/2833770>

Tekniske spesifikasjoner

Artikkelegenskaper

Produkttype	Pluggmodul
Produktserie	ESSENTIAL edition

Elektriske egenskaper

Nominell spenning U_N	12 V DC ... 24 V DC
-------------------------	---------------------

Inngangsdata

Inngangsspenningsområde	12 V DC ... 24 V DC
Beskyttelseskobling	Friløpsdiode, LED

Montering

Monteringstype	Pluggmontering
----------------	----------------

LDP3- 12- 24DC - Stikkmodul

2833770

El-nr.: 4315018

<https://www.phoenixcontact.com/no/produkter/2833770>



Tegninger

Koblingskjema

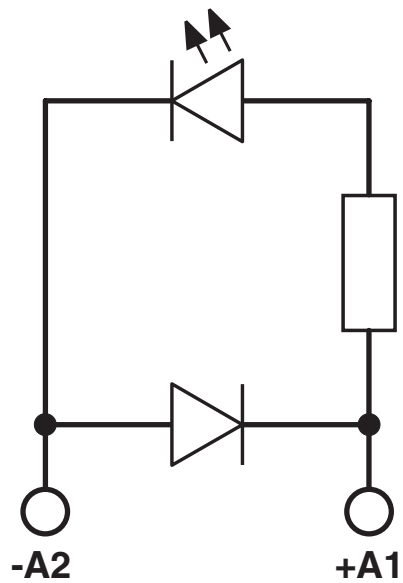

LDP3- 12- 24DC - Stikkmodul



2833770

EI-nr.: 4315018

<https://www.phoenixcontact.com/no/produkter/2833770>

Godkjenninger

To download certificates, visit the product detail page: <https://www.phoenixcontact.com/no/produkter/2833770>



cUL Recognized

Godkjennings-ID: FILE E 140324



UL Recognized

Godkjennings-ID: FILE E 140324



EAC

Godkjennings-ID: RU C-DE.A*30.B.01742

cULus Recognized

LDP3- 12- 24DC - Stikkmodul



2833770

EI-nr.: 4315018

<https://www.phoenixcontact.com/no/produkter/2833770>

Klassifiseringer

ECLASS

ECLASS-11.0	27371692
ECLASS-12.0	27371692
ECLASS-13.0	27371692

ETIM

ETIM 9.0	EC002586
----------	----------

UNSPSC

UNSPSC 21.0	39122300
-------------	----------

LDP3- 12- 24DC - Stikkmodul



2833770

EI-nr.: 4315018

<https://www.phoenixcontact.com/no/produkter/2833770>

Environmental product compliance

China RoHS	Tidsrom for forskriftsmessig bruk: ubegrenset = EFUP-e
	Ingen farlige stoffer over grenseverdiene

Phoenix Contact 2023 © - Alle rettigheter forbeholdt
<https://www.phoenixcontact.com>

PHOENIX CONTACT AS
Strømsveien 344
N-1081 Oslo
+47 22 07 68 00
norge@phoenixcontact.com