



Hovedkarakteristikk

Produktspekter	Altivar 71
Produkt eller komponent type	Frekvensomformer
Produktspesifikk applikasjon	Complex, high-power machines
Type komponent	ATV71
Motoreffekt kW	11 kW på 380...480 V 3 faser
Motoreffekt hk	15 hp på 380...480 V 3 faser
Motorkabelengde	
[Us] matespenning	380...480 V (- 15...10 %)
Antall faser	3 faser
Nettstrøm	30 A for 480 V 3 faser 11 kW / 15 hp 36.6 A for 380 V 3 faser 11 kW / 15 hp
EMC filter	Integrert
Monteringsmåte	Med kjølelegeme
Variant	Forsterket versjon
Tilsynelatende effekt	24.1 kVA på 380 V 3 faser 11 kW / 15 hp
Maks kortslutningsnivå I _{sc}	<= 22 kA, 3 faser
Nominell utgangsstrøm	21 A at 4 kHz 460 V 3 faser 11 kW / 15 hp 27.7 A at 4 kHz 380 V 3 faser 11 kW / 15 hp
Maksimal transient strøm	41.6 A for 60 s 3 faser 11 kW / 15 hp 45.7 A for 2 s 3 faser 11 kW / 15 hp
Output frequency	0.1...599 Hz
Nominell svitsjefrekvens	4 kHz
Switching frequency	1...16 kHz Justrbar 4...16 kHz with derating factor
Motorkontroll metode	ENA (Energy tilpasning) system for ubalanserte laster Fluks vektor kontroll (FVC) med sensor (strømvektor) Sensorløs fluks vektor kontroll (SFVC) (spenning eller strøm vektor) Spennings- / frekvensforhold (2 eller 5 poeng)
Polarisasjonstype	No impedance for Modbus

Alternativer

Produsert i	Asynkrone motorer Synchronous motors
Spenningsgrenser	323...528 V
Nettffrekvens	50...60 Hz (- 5...5 %)
Nettverksfrekvens	47.5...63 Hz
Speed range	1...100 for asynchronous motor in open-loop mode, without speed feedback 1...50 for synchronous motor in open-loop mode, without speed feedback 1...1000 for asynchronous motor in closed-loop mode with encoder feedback
Hastighet nøyaktighet	+/- 0.01 % of nominal speed for 0.2 T _n to T _n torque variation in closed-loop mode with encoder feedback +/- 10 % of nominal slip for 0.2 T _n to T _n torque variation without speed feedback
Dreiemoment nøyaktighet	+/- 15 % in open-loop mode, without speed feedback +/- 5 % in closed-loop mode with encoder feedback
Forbigående overbelastning (vridmoment)	220 % of nominal motor torque +/- 10 % for 2 s 170 % of nominal motor torque +/- 10 % for 60 s every 10 minutes
Bremsemoment	<= 150 % with braking or hoist resistor 30 % without braking resistor
Synchronous motor control profile	Vector control without speed feedback
Reguleringsløyfe	Justerbar PI regulator

&nbps;informasjonen i denne dokumentasjonen inneholder generelle beskrivelser og / eller tekniske egenskaper ved ytelsen til produktene heri.
 Denne dokumentasjonen er ikke tenkt som en erstatning for, og skal ikke brukes til avgjørelse for egnethet eller pålitelighet av disse produktene til spesifikke brukerapplikasjoner.
 Det er brukers eller integrators plikt til å foreta den nødvendige risikoanalyse, evaluering og utprøving av produkter med hensyn til den relevante spesifikke anvendelse eller bruk.
 Hverken Schneider Electric Industries SAS, eller noen av de tilknyttede selskaper eller datterselskaper er ansvarlig for, eller hfter for misbruk av innværende opplysninger.

Motor slip kompensasjon	Justrbar Automatic whatever the load Not available in voltage/frequency ratio (2 or 5 points) Suppressable
Lokal varsling	1 LED rød presence of drive voltage
Utgangsspenning	<= strømforsyningsspenning
Isolasjon	Electrical between power and control
Type kabel	With a NEMA Type1 kit: 3-strand UL 508 cable på 40 °C, copper 75 °C PVC With an IP21 or an IP31 kit: 3-strand IEC cable på 40 °C, copper 70 °C PVC Without mounting kit: 1-strand IEC cable på 45 °C, copper 70 °C PVC Without mounting kit: 1-strand IEC cable på 45 °C, copper 90 °C XLPE/EPR
Elektrisk tilkobling	AI1-/AI1+, AI2, AO1, R1A, R1B, R1C, R2A, R2B, LI1...LI6, PWR klemme 2.5 mm ² / AWG 14 L1/R, L2/S, L3/T, U/T1, V/T2, W/T3, PC/-, PO, PA/+, PA, PB klemme 16 mm ² / AWG 4
Tiltrekningsmoment	L1/R, L2/S, L3/T, U/T1, V/T2, W/T3, PC/-, PO, PA/+, PA, PB 3 N.m / 26.5 lb.in AI1-/AI1+, AI2, AO1, R1A, R1B, R1C, R2A, R2B, LI1...LI6, PWR 0.6 N.m
Supply	Internal supply for reference potentiometer (1 to 10 kOhm), 10.5 V DC +/- 5 %, <= 10 mA for overload and short-circuit protection Internal supply, 24 V DC, voltage limits 21...27 V, <= 200 mA for overload and short-circuit protection
Antall analoge innganger	2
Analogue input type	AI1-/AI1+ bipolar differential voltage +/- 10 V DC, input voltage 24 V max, resolution 11 bits + sign AI2 software-configurable current 0...20 mA, impedance 242 Ohm, resolution 11 bits AI2 software-configurable voltage 0...10 V DC, input voltage 24 V max, impedance 30000 Ohm, resolution 11 bits
Sampling varighet	AI1-/AI1+ 2 ms, +/- 0.5 ms for analog input(s) AI2 2 ms, +/- 0.5 ms for analog input(s) LI1...LI5 2 ms, +/- 0.5 ms for discrete input(s) LI6 (if configured as logic input) 2 ms, +/- 0.5 ms for discrete input(s)
Responstid	<= 100 ms in STO (Safe Torque Off) AO1 2 ms, tolerance +/- 0.5 ms for analog output(s) R1A, R1B, R1C 7 ms, tolerance +/- 0.5 ms for discrete output(s) R2A, R2B 7 ms, tolerance +/- 0.5 ms for discrete output(s)
Nøyaktighet	AI1-/AI1+ +/- 0.6 % for a temperature variation 60 °C AI2 +/- 0.6 % for a temperature variation 60 °C AO1 +/- 1 % for a temperature variation 60 °C
Lineær feil	AI1-/AI1+, AI2 +/- 0.15 % of maximum value AO1 +/- 0.2 %
Analog utgangsnummer	1
Analog utgangstype	AO1 software-configurable current 0...20 mA, impedance 500 Ohm, resolution 10 bits AO1 software-configurable logic output 10 V <= 20 mA AO1 software-configurable voltage 0...10 V DC, impedance 470 Ohm, resolution 10 bits
Discrete output number	2
Digitale utganger	R1A, R1B, R1C configurable relay logic NO/NC, electrical durability 100000 sykluser R2A, R2B configurable relay logic Nei, electrical durability 100000 sykluser
Minimum brytestrøm	Configurable relay logic 3 mA på 24 V DC
Maximum svitsjestrøm	R1, R2 på ohmsk last, 5 A på 250 V AC, cos phi = 1, R1, R2 på ohmsk last, 5 A på 30 V DC, cos phi = 1, R1, R2 på induktiv last, 2 A på 250 V AC, cos phi = 0.4, R1, R2 på induktiv last, 2 A på 30 V DC, cos phi = 0.4,
Discrete input number	7
Discrete input type	LI6: programmerbar bryter 24 V DC med nivå 1 PLC, impedance: 3500 Ohm PWR: safety input 24 V DC, impedance: 1500 Ohm i samsvar med ISO 13849-1 level d LI1...LI5: programmerbar 24 V DC med nivå 1 PLC, impedance: 3500 Ohm LI6: switch-configurable PTC probe 0...6, impedance: 1500 Ohm
Diskrét inngangs logikk	LI1...LI5 positive logic (source), < 5 V (state 0), > 11 V (state 0) LI1...LI5 negative logic (sink), > 16 V (state 0), < 10 V (state 0) LI6 (if configured as logic input) positive logic (source), < 5 V (state 0), > 11 V (state 0) LI6 (if configured as logic input) negative logic (sink), > 16 V (state 0), < 10 V (state 0)
Akselerasjons- og retardasjonsramper	Automatisk tilpasning av rampen hvis bremsekapasitet overskrides, ved hjelp av motstand Lineær justerbare separat fra 0,01 til 9000 s S, U eller tilpasset
Bremsing til stillstand	Ved DC-bremsing
Beskyttelsestype	Drive mot overskridelse av hastighetsgrenser Drive mot bortfall av nettfase

	Drive break on the control circuit Drive input phase breaks Drive line supply overvoltage Drive line supply undervoltage Drive overcurrent between output phases and earth Drive overheating protection Drive overvoltages on the DC bus Drive short-circuit between motor phases Drive thermal protection Motor mot brudd av motorfase Motor power removal Motor thermal protection
Isolasjonsmotstand	> 1 mOhm på 500 V DC for 1 minute to earth
Frekvensopløsning	Analog inngang 0.024/50 Hz Display unit 0,1 Hz
Kommunikasjonsprotokoll	CANopen Modbus
Type konnektor	1 RJ45 for Modbus on front face 1 RJ45 for Modbus on terminal Male SUB-D 9 on RJ45 for CANopen
Fysisk interface	2-wire RS 485 for Modbus
Ramme for overføring	RTU for Modbus
Transmission rate	20 kbps, 50 kbps, 125 kbps, 250 kbps, 500 kbps, 1 Mbps for CANopen 4800 bps, 9600 bps, 19200 bps, 38.4 Kbps for Modbus on terminal 9600 bps, 19200 bps for Modbus on front face
Datoformat	8 bits, 1 stop, even parity for Modbus on front face 8 bits, odd even or no configurable parity for Modbus on terminal
Antall adresser	1...247 for Modbus 1...127 for CANopen
Tilgangsmetode	Slave for CANopen
Merking	CE
Driftsposisjon	Vertikal +/- 10 grader
Høyde	295 mm
Dybde	213 mm
Bredde	210 mm
Vekt	8 kg
Funksjonskort	CC-Link kommunikasjon kort Controller inside programmable card DeviceNet kommunikasjon kort Ethernet/IP kommunikasjon kort Fipio kommunikasjon kort I/O extension card Interbus-S kommunikasjon kort Interface card for encoder Modbus Plus kommunikasjon kort Modbus TCP kommunikasjon kort Modbus/Uni-Telway kommunikasjon kort Overhead crane card Profibus DP kommunikasjon kort Profibus DP V1 kommunikasjon kort

Miljø

noise level	57.4 dB i samsvar med 86/188/EEC
dielektrisk styrke	3535 V DC between earth and power terminals 5092 V DC between control and power terminals
elektromagnetisk kompatibilitet	Conducted radio-frequency immunity test i samsvar med IEC 61000-4-6 nivå 3 Electrical fast transient/burst immunity test i samsvar med IEC 61000-4-4 nivå 4 Immunitetstest for elektrostatisk utladning i samsvar med IEC 61000-4-2 nivå 3 Radiated radio-frequency electromagnetic field immunity test i samsvar med IEC 61000-4-3 nivå 3 Voltage dips and interruptions immunity test i samsvar med IEC 61000-4-11 1.2/50 µs - 8/20 µs surge immunity test i samsvar med IEC 61000-4-5 nivå 3
standarder	EN 55011 klasse A gruppe 2 EN 61800-3 environments 1 category C3 EN 61800-3 environments 2 category C3 EN/IEC 61800-3 EN/IEC 61800-5-1 IEC 60721-3-3 class 3C2 UL Type 1

produktcertifikater	CSA C-Tick GOST NOM 117 UL
Forurensninggrad	2 i henhold til EN/IEC 61800-5-1
IP-grad	IP20 on upper part without blanking plate on cover i samsvar med EN/IEC 60529 IP20 on upper part without blanking plate on cover i samsvar med EN/IEC 61800-5-1 IP21 i samsvar med EN/IEC 60529 IP21 i samsvar med EN/IEC 61800-5-1 IP41 on upper part i samsvar med EN/IEC 60529 IP41 on upper part i samsvar med EN/IEC 61800-5-1 IP54 on lower part i samsvar med EN/IEC 60529 IP54 on lower part i samsvar med EN/IEC 61800-5-1
Vibrasjonsmotstand	1.5 mm peak to peak (f = 3...13 Hz) i samsvar med EN/IEC 60068-2-6 1 gn (f = 13...200 Hz) i henhold til EN/IEC 60068-2-6
støtmotstand	15 gn for 11 ms i henhold til EN/IEC 60068-2-27
relativ fuktighet	5...95 % uten kondens i henhold til IEC 60068-2-3 5...95 % without dripping water i samsvar med IEC 60068-2-3
omgivelsestemperatur for drift	-10...50 °C uten lastreduksjon
omgivelsestemperatur for lagring	-25...70 °C
operating altitude	<= 1000 m uten lastreduksjon 1000...3000 m with current derating 1 % per 100 m

UL Type 1/IP 20 Drives

Dimensions without Option Card

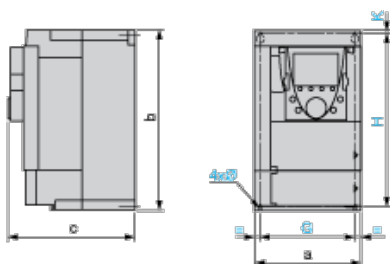

Dimensions in mm

a	b	c	G	H	K	Ø
210	295	213	190	283	6	6

Dimensions in in.

a	b	c	G	H	K	Ø
8.26	11.61	8.38	7.48	11.14	0.23	0.23

Dimensions with 1 Option Card (1)

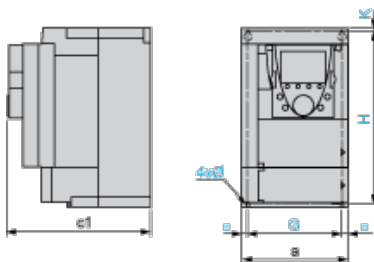

Dimensions in mm

a	c1	G	H	K	Ø
210	236	190	283	6	6

Dimensions in in.

a	c1	G	H	K	Ø

8.26	9.29	7.48	11.14	0.23	0.23
------	------	------	-------	------	------

(1) Option cards: I/O extension cards, communication cards or "Controller Inside" programmable card.

Dimensions with 2 Option Cards (1)

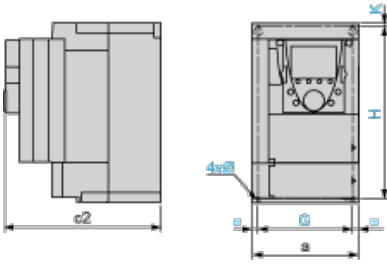

Dimensions in mm

a	c2	G	H	K	Ø
210	259	190	283	6	6

Dimensions in in.

a	c2	G	H	K	Ø
8.26	10.20	7.48	11.14	0.23	0.23

(1) Option cards: I/O extension cards, communication cards or "Controller Inside" programmable card.

Mounting Recommendations

Depending on the conditions in which the drive is to be used, its installation will require certain precautions and the use of appropriate accessories.

Install the unit vertically:

- ┆ Avoid placing it close to heating elements
- ┆ Leave sufficient free space to ensure that the air required for cooling purposes can circulate from the bottom to the top of the unit.

Clearance

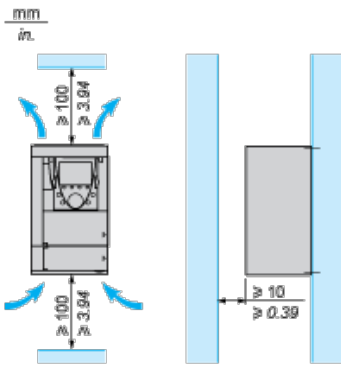

Mounting Types

Type A Mounting

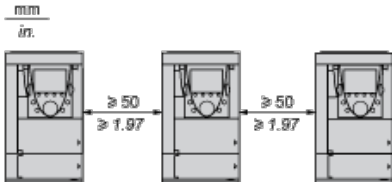

Type B Mounting

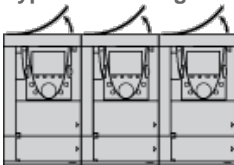

Type C Mounting

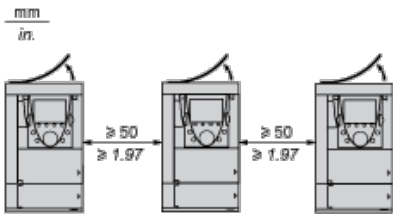

By removing the protective blanking cover from the top of the drive, the degree of protection for the drive becomes IP 20.

The protective blanking cover may vary according to the drive model (refer to the user guide).

The protective blanking cover must be removed from ATV 71P•••N4Z drives when they are mounted in a dust and damp proof enclosure.

Specific Recommendations for Mounting the Drive in an Enclosure

Ventilation

To ensure proper air circulation in the drive:

- 1 Fit ventilation grilles.
- 1 Ensure that there is sufficient ventilation. If there is not, install a forced ventilation unit with a filter. The openings and/or fans must provide a flow rate at least equal to that of the drive fans (refer to the product characteristics).

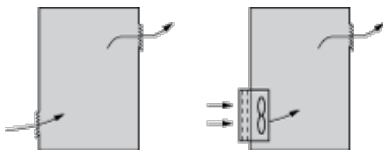

- 1 Use special filters with IP 54 protection.
- 1 Remove the blanking cover from the top of the drive.

Dust and Damp Proof Metal Enclosure (IP 54)

The drive must be mounted in a dust and damp proof enclosure in certain environmental conditions: dust, corrosive gases, high humidity with risk of condensation and dripping water, splashing liquid, etc.

This enables the drive to be used in an enclosure where the maximum internal temperature reaches 50°C.

Wiring Diagram Conforming to Standards EN 954-1 Category 1, IEC/EN 61508 Capacity SIL1, in Stopping Category 0 According to IEC/EN 60204-1

Three-Phase Power Supply with Upstream Breaking via Contactor

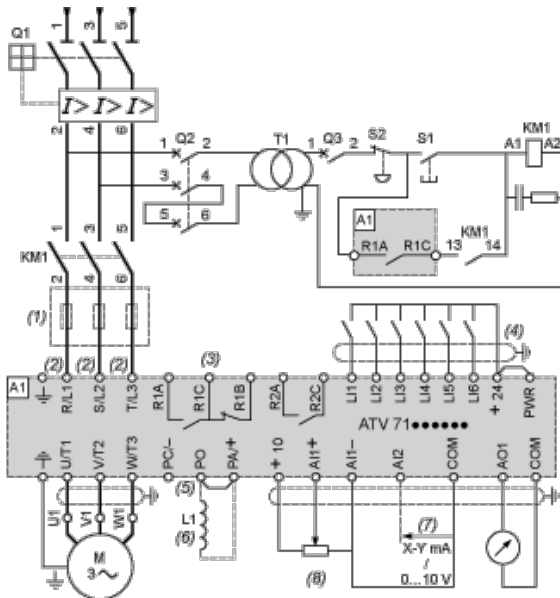

A1 ATV71 drive

KM1 Contactor

L1 DC choke

Q1 Circuit-breaker

Q2 GV2 L rated at twice the nominal primary current of T1

Q3 GB2CB05

S1, XB4 B or XB5 A pushbuttons

Three-Phase Power Supply, Low Inertia Machine, Vertical Movement

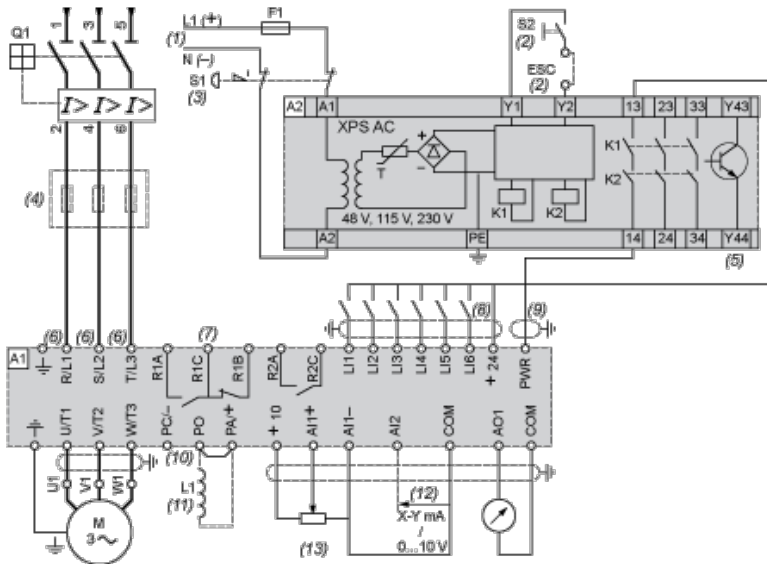

- A1 ATV71 drive
- A2 Preventa XPS AC safety module for monitoring emergency stops and switches. One safety module can manage the "Power Removal" function for several drives on the same machine. In this case, each drive must connect its PWR terminal to its + 24 V via the safety contacts on the XPS AC module. These contacts are independent for each drive.
- F1 Fuse
- L1 DC choke
- Q1 Circuit-breaker
- S1 Emergency stop button with 2 contacts
- S2 XB4 B or XB5 A pushbutton
- (1) Power supply: 24 Vdc or Vac, 48 Vac, 115 Vac, 230 Vac.
- (2) S2: resets XPS AC module on power-up or after an emergency stop. ESC can be used to set external starting conditions.
- (3) Requests freewheel stopping of the movement and activates the "Power Removal" safety function.
- (4) Line choke (three-phase), mandatory for and ATV71HC11Y...HC63Y drives (except when a special transformer is used (12-pulse)).
- (5) The logic output can be used to signal that the machine is in a safe stop state.
- (6) For ATV71HC40N4 drives combined with a 400 kW motor, ATV71HC50N4 and ATV71HC40Y...HC63Y, refer to the power terminal connections diagram.
- (7) Fault relay contacts. Used for remote signalling of the drive status.
- (8) Connection of the common for the logic inputs depends on the positioning of the SW1 switch. The above diagram shows the internal power supply switched to the "source" position (for other connection types, refer to the user guide).
- (9) Standardized coaxial cable, type RG174/U according to MIL-C17 or KX3B according to NF C 93-550, external diameter 2.54 mm / 0.09 in., maximum length 15 m / 49.21 ft. The cable shielding must be earthed.
- (10) There is no PO terminal on ATV71HC11Y...HC63Y drives.
- (11) Optional DC choke for ATV71H...M3, ATV71HD11M3X...HD45M3X, ATV71•075N4...•D75N4 and ATV71P...N4Z drives. Connected in place of the strap between the PO and PA/+ terminals. For ATV71HD55M3X, HD75M3X, ATV71HD90N4...HC50N4 drives, the choke is supplied with the drive; the customer is responsible for connecting it.
- (12) Software-configurable current (0...20 mA) or voltage (0...10 V) analog input.
- (13) Reference potentiometer.

All terminals are located at the bottom of the drive. Fit interference suppressors on all inductive circuits near the drive or connected on the same circuit, such as relays, contactors, solenoid valves, fluorescent lighting, etc.

Wiring Diagram Conforming to Standards EN 954-1 Category 3, IEC/EN 61508 Capacity SIL2, in Stopping Category 1 According to IEC/EN 60204-1

Three-Phase Power Supply, High Inertia Machine

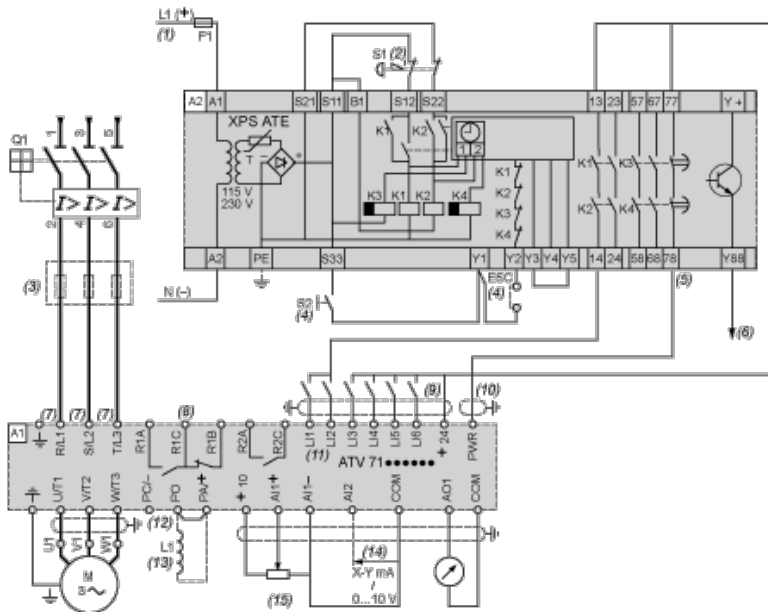

- A1 ATV71 drive
- A2 Preventa XPS ATE safety module for monitoring emergency stops and switches. One safety module can manage the "Power Removal" safety function for several drives on the same machine. In this case the time delay must be adjusted on the drive controlling the motor that requires the longest stopping time. In addition, each drive must connect its PWR terminal to its + 24 V via the safety contacts on the XPS ATE module. These contacts are independent for each drive.
- (5) Removal safety function for several drives on the same machine. In this case the time delay must be adjusted on the drive controlling the motor that requires the longest stopping time. In addition, each drive must connect its PWR terminal to its + 24 V via the safety contacts on the XPS ATE module. These contacts are independent for each drive.
- F1 Fuse
- L1 DC choke
- Q1 Circuit-breaker
- S1 Emergency stop button with 2 N/C contacts
- S2 Run button
- (1) Power supply: 24 Vdc or Vac, 115 Vac, 230 Vac.
- (2) Requests controlled stopping of the movement and activates the "Power Removal" safety function.
- (3) Line choke (three-phase), mandatory for ATV71HC11Y...HC63Y drives (except when a special transformer is used (12-pulse)).
- (4) S2: resets XPS ATE module on power-up or after an emergency stop. ESC can be used to set external starting conditions.
- (5) For stopping times requiring more than 30 seconds in category 1, use a Preventa XPS AV safety module which can provide a maximum time delay of 300 seconds.
- (6) The logic output can be used to signal that the machine is in a safe state.
- (7) For ATV71HC40N4 drives combined with a 400 kW motor, ATV71HC50N4 and ATV71HC40Y...HC63Y, refer to the power terminal connections diagram.
- (8) Fault relay contacts. Used for remote signalling of the drive status.
- (9) Connection of the common for the logic inputs depends on the positioning of the SW1 switch. The above diagram shows the internal power supply switched to the "source" position (for other connection types, refer to the user guide).
- (10) Standardized coaxial cable, type RG174/U according to MIL-C17 or KX3B according to NF C 93-550, external diameter 2.54 mm/0.09 in., maximum length 15 m/49.21 ft. The cable shielding must be earthed.
- (11) Logic inputs LI1 and LI2 must be assigned to the direction of rotation: LI1 in the forward direction and LI2 in the reverse direction.
- (12) There is no PO terminal on ATV71HC11Y...HC63Y drives.
- (13) Optional DC choke for ATV71H...M3, ATV71HD11M3X...HD45M3X, ATV71•075N4...•D75N4 and ATV71P...N4Z drives. Connected in place of the strap between the PO and PA/+ terminals. For ATV71HD55M3X, HD75M3X, ATV71HD90N4...HC50N4 drives, the choke is supplied with the drive; the customer is responsible for connecting it.
- (14) Software-configurable current (0...20 mA) or voltage (0...10 V) analog input.
- (15) Reference potentiometer.

All terminals are located at the bottom of the drive. Fit interference suppressors on all inductive circuits near the drive or connected on the same circuit, such as relays, contactors, solenoid valves, fluorescent lighting, etc.

Derating Curves

The derating curves for the drive nominal current (I_n) depend on the temperature, the switching frequency and the mounting type. For intermediate temperatures (e.g. 55°C), interpolate between 2 curves.

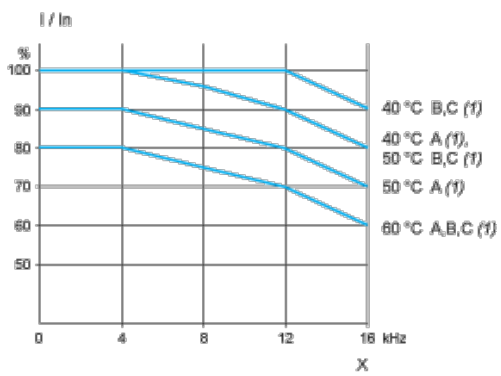

X Switching frequency

(1) Mounting type