

INSTALLATION INSTRUCTION

Enclosed Safety Switches and Switch-Disconnectors

OT200...1600_, OKL125-720_

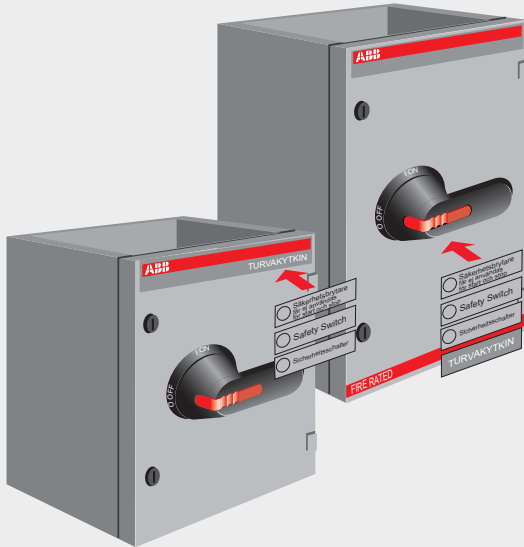

Terminal markings

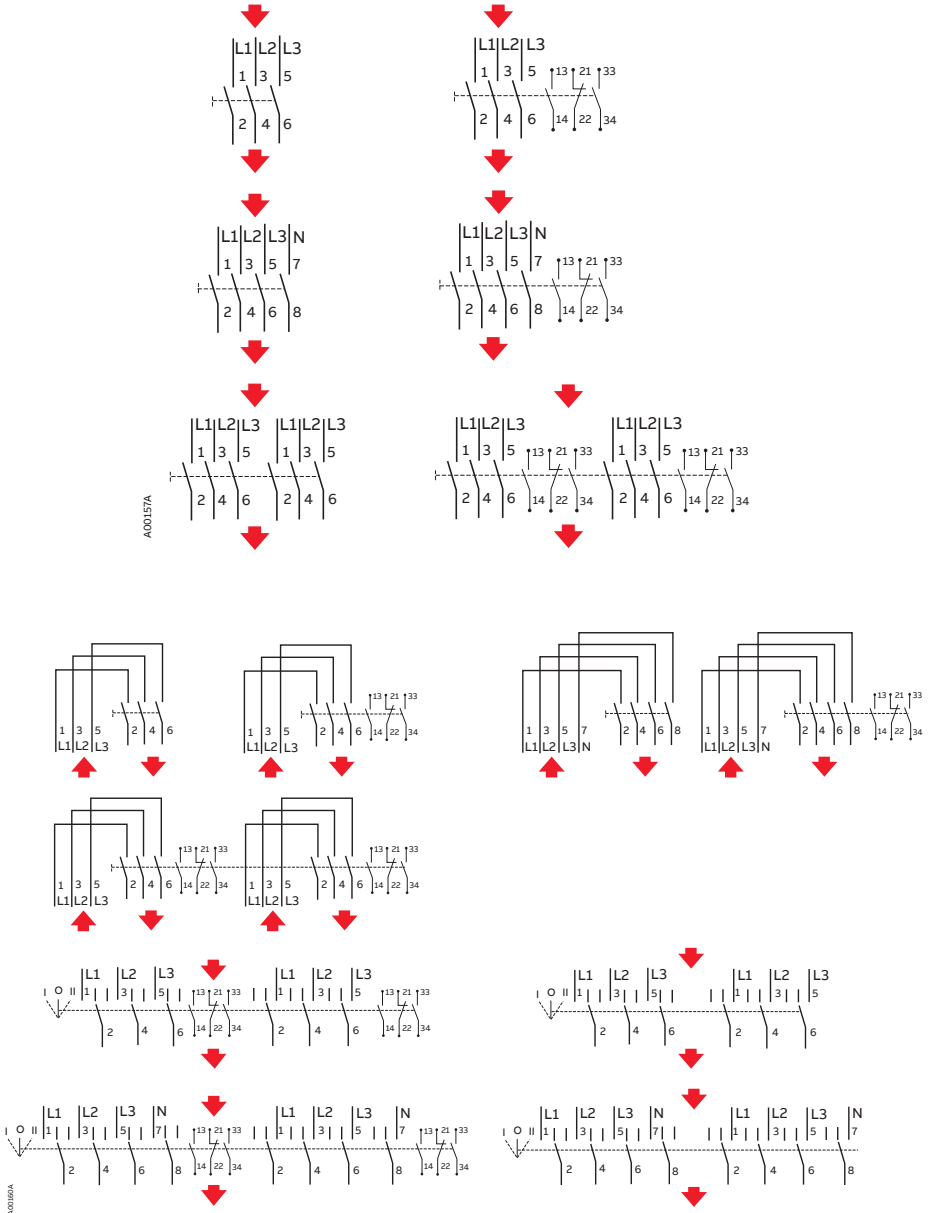

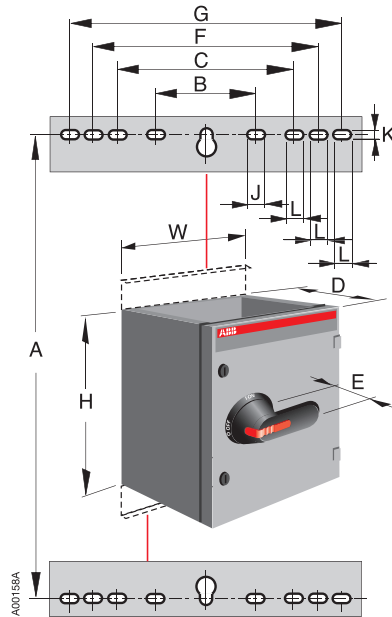

Enclosure dimensions and fixing



[mm]	H	W	D	E	A	B	C	F	G	J	K	L
400 x 250 x 180	400	250	180	45	445	162	-	-	-	27	11	-
400 x 400 x 230	400	400	230	45	445	303	-	-	-	35	11	-
400 x 400 x 330	400	400	330	45	445	303	-	-	-	35	11	-
600 x 400 x 230	600	400	230	45	645	303	-	-	-	35	11	-
600 x 400 x 330	600	400	330	45	645	303	-	-	-	35	11	-
600 x 400 x 430	600	400	430	45	645	303	-	-	-	35	11	-
800 x 400 x 230	800	400	230	45	845	303	-	-	-	35	11	-
800 x 400 x 330	800	400	330	45	845	303	-	-	-	35	11	-
1000 x 400 x 230	1000	400	230	45	1045	303	-	-	-	35	11	-
1000 x 400 x 330	1000	400	330	45	1045	303	-	-	-	35	11	-
1200 x 400 x 230	1200	400	230	45	1245	303	-	-	-	35	11	-
1200 x 400 x 330	1200	400	330	45	1245	303	-	-	-	35	11	-
400 x 800 x 230	400	800	230	45	445	303	512	612	712	35	11	27
400 x 800 x 330	400	800	330	45	445	303	512	612	712	35	11	27
600 x 800 x 230	600	800	230	45	645	303	512	612	712	35	11	27
600 x 800 x 330	600	800	330	45	645	303	512	612	712	35	11	27
800 x 800 x 230	800	800	230	45	845	303	512	612	712	35	11	27
800 x 800 x 330	800	800	330	45	845	303	512	612	712	35	11	27
1000 x 800 x 230	1000	800	230	45	1045	303	512	612	712	35	11	27
1000 x 800 x 330	1000	800	330	45	1045	303	512	612	712	35	11	27
1200 x 800 x 230	1200	800	230	45	1245	303	512	612	712	35	11	27
1200 x 800 x 330	1200	800	330	45	1245	303	512	612	712	35	11	27

Tightening torques of connectors

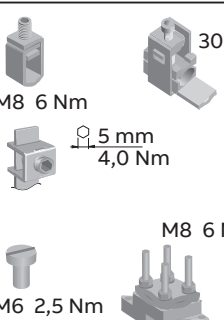
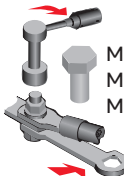
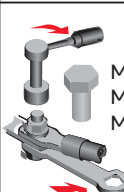
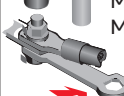
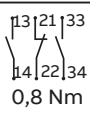
[Nm] ↻

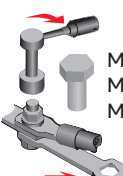
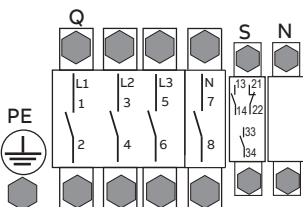
PE	Q	S	N
 <p>M8 6 Nm</p> <p>5 mm 4,0 Nm</p> <p>M8 6 Nm</p> <p>M6 2,5 Nm</p>  <p>M8 15...22 Nm M10 30...44 Nm M12 50...75 Nm</p>	 <p>M8 15...22 Nm M10 30...44 Nm M12 50...75 Nm</p> 	 <p>13 21 33 14 22 34 0,8 Nm</p>	 <p>M8 6 Nm</p> <p>M8 15...22 Nm M10 30...44 Nm M12 50...75 Nm</p> 
 <p>Q S N</p> <p>PE</p> <p>L1 1 2 L2 3 4 L3 5 6 N 7 8</p> <p>13 21 33 14 22 34</p>			

Handle padlocking and bypass locking in ON-position

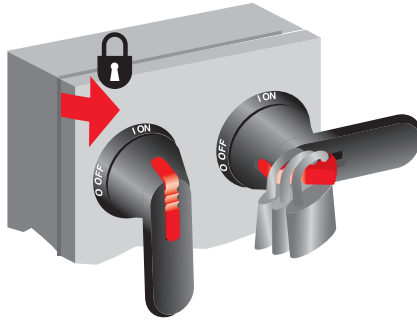

Ø5...10 mm

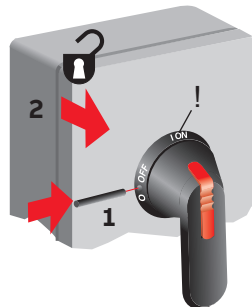
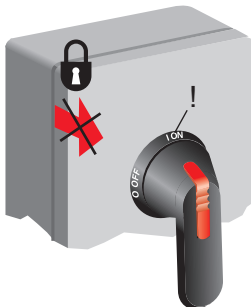
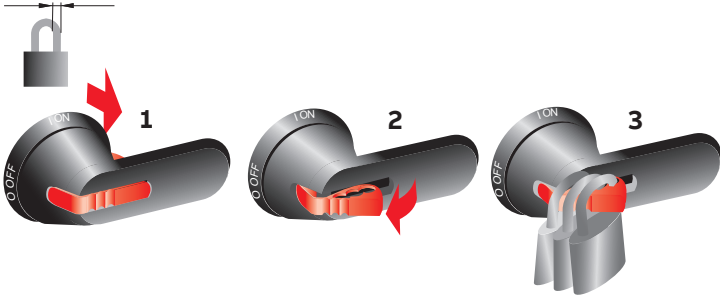

Contact us

ABB Oy

Muottitie 2A, 65320

Vaasa, Finland

abb.com/lowvoltage



BG	Внимание! Опасно напрежение! Да се монтира само от лице с електротехническа квалификация.
FR	Avertissement! Tension électrique dangereuse! Installation uniquement par des personnes qualifiées en électrotechnique.
MT	Twissija! Vultaġġ perikoluż! Għandu jġi installat biss minn persuna b'kompetenza elettroteknika.
HR	Upozorenje! Opasan napon! Postavljati smije samo elektrotehnički stručnjak.
DE	Warnung! Gefährliche Spannung! Installation nur durch elektrotechnische Fachkraft.
PL	Ostrzeżenie! Niebezpieczne napięcie! Instalacji może dokonać wyłącznie osoba z fachową wiedzą w dziedzinie elektrotechniki.
CZ	Varování! Nebezpečné napětí! Montáž smí provádět výhradně elektrotechnik!
EL	Προειδοποίηση! Υψηλή τάση! Η εγκατάσταση πρέπει να γίνεται μόνο από εξειδικευμένους ηλεκτροτεχνικούς.
PT	Aviso! Tensão perigosa! A instalação só deve ser realizada por um eletricitista especializado.
DA	Advarsel! Farlig elektrisk spænding! Installation må kun foretages af personer med elektroteknisk ekspertise.
HU	Figyelmeztetés! Veszélyes feszültség! Csak elektrotechnikai tapasztalattal rendelkező szakember helyezheti üzembe.
RO	Avertizare! Tensiune periculoasă! Instalarea trebuie efectuată numai de către o persoană cu experiență în electrotehnică.
NL	Waarschuwing! Gevaarlijke spanning! Mag alleen geïnstalleerd worden door een deskundige elektrotechnicus.
IE	Rabhadh! Voltas guaiseach! Ba chóir do dhuine ag a bhfuil saineolas leictreicniúil, agus an té sin amháin, é seo a shuiteáil.
SK	Varovanie! Nebezpečné napätie! Montáž môže vykonávať iba skúsený elektrotechnik.
EN	Warning! Hazardous voltage! Installation by person with electrotechnical expertise only.
IT	Avvertenza! Tensione pericolosa! Fare installare solo da un elettricista qualificato.
SL	Opozorilo! Nevarna napetost! Vgradnjo lahko opravi le oseba z elektrotehničnim strokovnim znanjem.
ET	Hoiatus! Ohtlik pinge. Paigaldada võib ainult elektrotehnikalaalne ekspert.
LV	Uzmanību! Bīstami - elektrība! Montāžas darbus drīkst veikt tikai personas, kurām ir atbilstošas elektrotehnikās zināšanas.
ES	¡Advertencia! ¡Tensión peligrosa! La instalación deberá ser realizada únicamente por electricistas especializados.
FI	Varoitus! Vaarallinen jännite! Asennuksen voi tehdä vain sähköalan ammattihenkilö.
LT	Dėmesio! Pavojinga įtampa! Dirbti leidžiama tik elektrotechniko patirties turinties asmenims.
SE	Varning! Farlig spänning! Installation får endast utföras av elektriker.
CN	警告！电压危险！只能由专业电工进行安装。
RU	Осторожно! Опасное напряжение! Монтаж должен выполняться только специалистом-электриком.