

**Bewegungsmelder Cube 120**

2442 ..

**Bewegungsmelder Cube 240**

2444 ..

**IR-Fernbedienung PIR 3**

2373 00

**GIRA**

## Inhaltsverzeichnis / table of contents

### DE

Bewegungsmelder Cube .....	8
IR-Fernbedienung PIR 3 .....	12

### EN

Motion detector Cube .....	16
IR remote control PIR 3 .....	20

### NL

Bewegingsmelder Cube .....	24
IR-afstandsbediening PIR 3 .....	28

### ES

Detector de movimiento Cube .....	32
Mando a distancia IR PIR 3 .....	37

# Wandmontage / wall installation



Bild / Fig. 1



Bild / Fig. 5

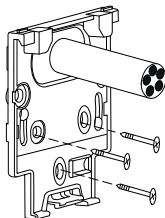

Bild / Fig. 2

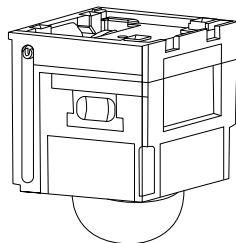

Bild / Fig. 6

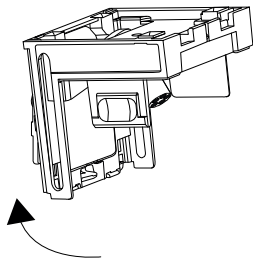

Bild / Fig. 3

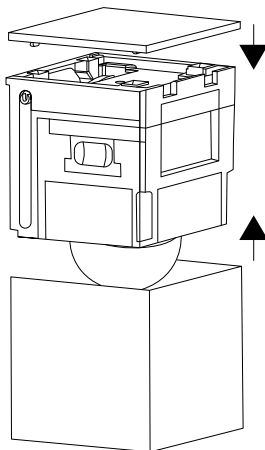

Bild / Fig. 4

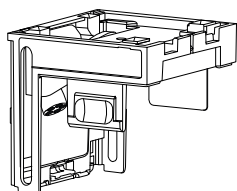

Bild / Fig. 7

# Deckenmontage / ceiling installation

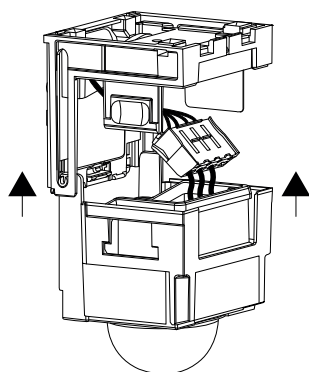

Bild / Fig. 8

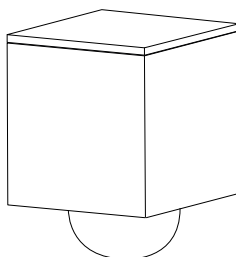

Bild / Fig. 12

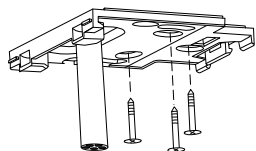

Bild / Fig. 9

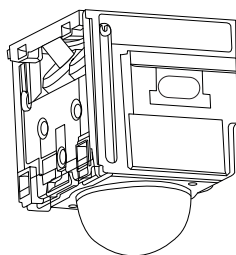

Bild / Fig. 13

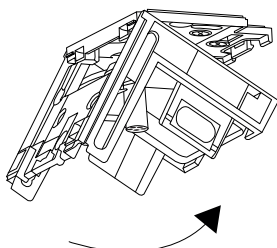

Bild / Fig. 10

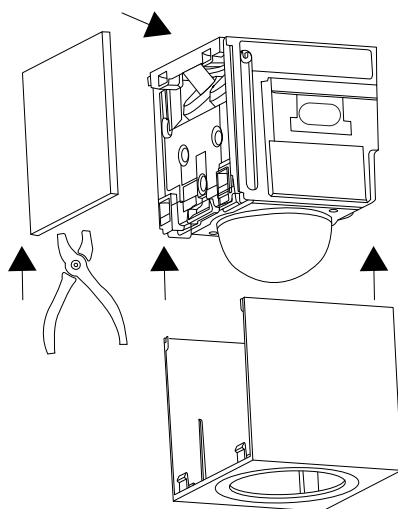

Bild / Fig. 11

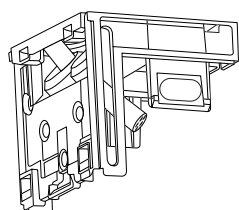

Bild / Fig. 14

# Anschlussplan / connection diagram

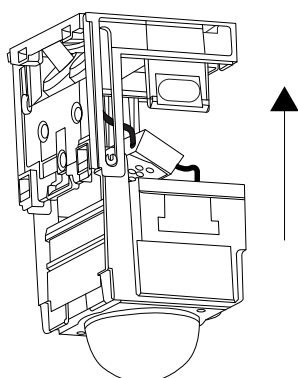

Bild / Fig. 15

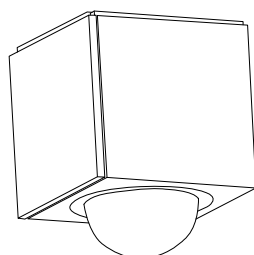

Bild / Fig. 17

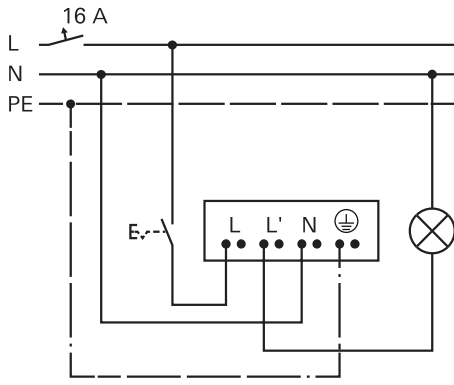

Bild / Fig. 16

# Erfassungsfeld / detection field

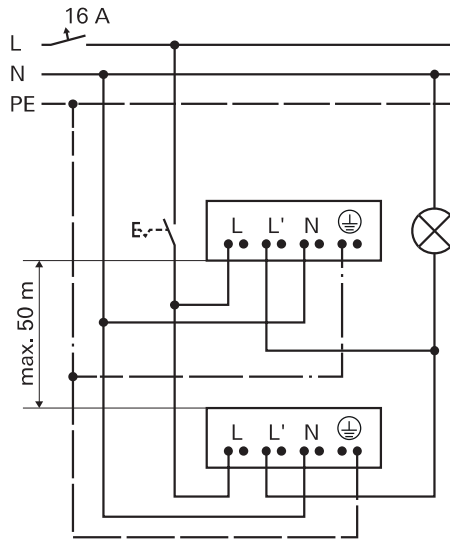

Bewegungsmelder Cube 120

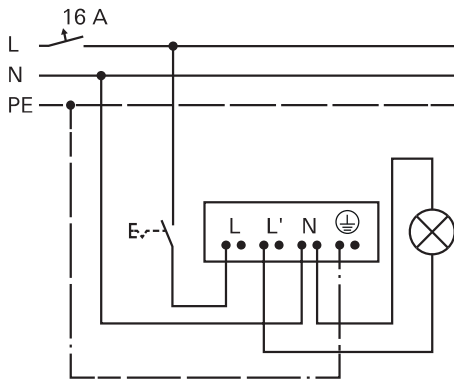
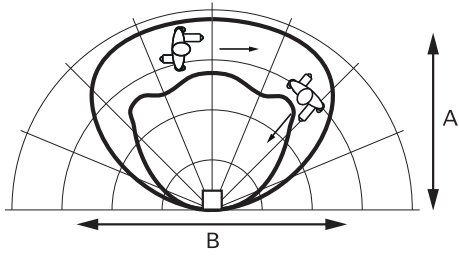
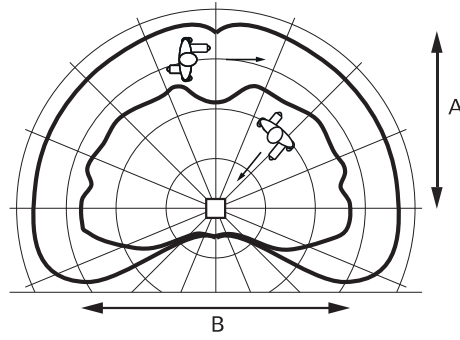

Bewegungsmelder Cube 240

	A x B	
25 %	≈ 4 x 6 m	≈ 0,5 x 1 m
50 %	≈ 7 x 7 m	≈ 1 x 2 m
75 %	≈ 12 x 20 m	≈ 2 x 4 m
100 %	≈ 16 x 22 m	≈ 4 x 7 m

Bild / Fig. 18

	A x B	
25 %	≈ 3 x 8 m	≈ 0,5 x 1 m
50 %	≈ 5 x 12 m	≈ 1 x 3 m
75 %	≈ 11 x 24 m	≈ 2 x 4 m
100 %	≈ 16 x 32 m	≈ 4 x 10 m

Bild / Fig. 19



Bild / Fig. 20

# Erfassungsfeld einschränken / Limit detection field



Bild / Fig. 21

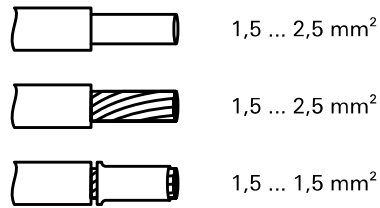

Bild / Fig. 24

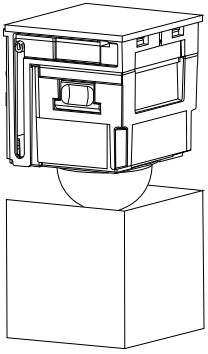

Bild / Fig. 22

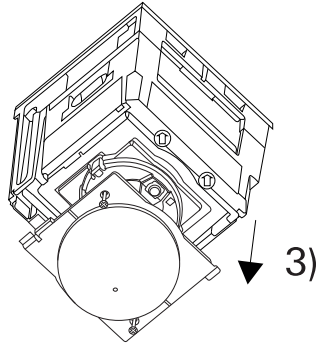

Bild / Fig. 25

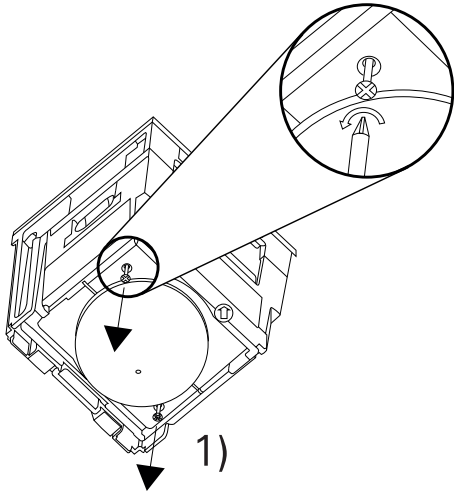

Bild / Fig. 23

**Motion detector Cube 120**

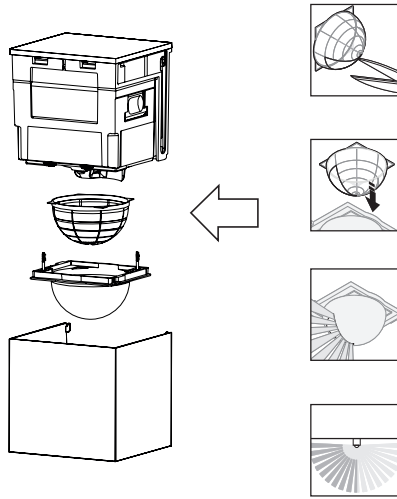
2442 ..

**Motion detector Cube 240**

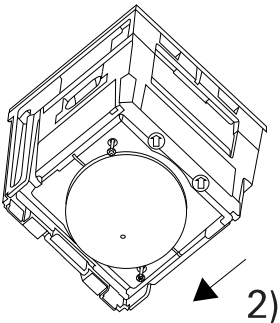
2444 ..

**IR remote control PIR 3**

2373 00

# GIRA

## Safety information



Electrical devices may only be installed and connected by a qualified electrician.

**Failure to observe the instructions can result in damage to the device, fire or other dangers.**

**Danger of electric shock. Device is not suitable for isolation.**

**Danger of electric shock. Isolate before working on the device or load. Take all circuit breakers supplying dangerous voltage to the device or load into account.**

**Do not press on the sensor window. This may damage the device.**

**The device is not suitable for use in burglar alarm technology or alarm technology.**

**These instructions are part of the product and must remain with the end customer.**

## Intended use

- Automatically switches lighting on/off, depending on thermal motion and ambient brightness.
- Suitable for indoor and outdoor ceiling mounting and wall installation.

## Product properties

- Floor and rear field monitoring (only with motion detector Cube 240).
- Continuous light (max. 2 h) can be activated with optional switch.
- Test mode for evaluation of the detection range.
- Individual adaptation of the detection range via the enclosed, cut-to-size covering panel.
- Delay time: 5 s to 15 minutes or short-term operation 1 s adjustable on the motion detector Cube.  
A delay time of max. 60 minutes can be set with the remote control PIR 3.
- Teach-in, save current twilight value.
- Glare protection, brightness independent sensor evaluation for 60 s in the event of glare caused by extraneous light.

- Short-time operation, output is switched on for approx. 1 s.
- Optional: Remote control via IR remote control PIR 3.



## Note

- Test operation is only possible with the optional IR remote control PIR 3.
- An optional cover with cable entry for Cube motion detectors is available for connecting a surface-mounted line.

## Automatic mode

The motion detector detects thermal movements of persons, animals or objects.

- The light is switched on if the detection range is entered and the set brightness threshold is not reached.
- The delay time is re-started with every motion detected.
- The light is switched off when no motion is detected any more in the detection range and the delay time expires or the ambient light is sufficiently bright.







## Response to a power failure

- Shorter than 0.2 s: Once the power supply is restored, the old switching position is re-established.
- Longer than 0.2 s: When the power supply is restored, the motion detector is in test mode for approx. 30 seconds.

## Operation

### Twilight setting controller

The switch-on threshold of the motion detector can be adjusted infinitely variably from approx. 2 to 1000 lx.

	Night mode approx. 2 lx
	Day mode Switches regardless of brightness level. <ul style="list-style-type: none"> <li>Set the setting controller to . The LED flashes five times for confirmation.</li> </ul>
	Teach-in Save ambient brightness as brightness threshold. <ul style="list-style-type: none"> <li>Set the setting controller to . The LED flashes five times for confirmation.</li> </ul> After 10 seconds, the measured ambient brightness value is saved. The load is switched off. Change value: Set the setting controller to any twilight value and then reset it to  to calibrate a new value.

### Setting controller time

Min.	delay time approx. 5 seconds
Max.	delay time approx. 15 minutes
	Short-time operation, the output is switched on for approx. 1 second. Afterwards, no movement is evaluated for approx. 8 seconds.



#### Note

If short-term operation  is set using the setting controller, the time cannot be set using the remote control.

### Operation with connected switch

The switch should be operated in the range of 0.5 to 1 second.

Switch 1x	Light ON	for set delay time
Switch 2x	Continuously ON	for 2 hours

Switching again cancels the permanent ON operating state.

## Mounting and electrical connection



#### DANGER!

**Risk of death from electric shock. Isolate the device. Cover any live parts.**

### Selecting the installation location

- The installation location should have a distance of at least 50 cm from any other light, since heat radiation can trigger the motion detector.
- Select a installation location that is free of vibrations, as vibrations can lead to unintentional switching.
- Take the direction of walking into account.
- Optimum mounting height of 2.50 m.
- Not included in scope of supply. Wall plugs, ø 6, and round head screws 6 x 35 mm for assembly.

### Detection field

Motion detector Cube 120, mounting height 2.5 m (Fig. 18)

Motion detector Cube 240, mounting height 2.5 m (Fig. 19)

### Wall installation

- Fasten the mounting plate to the wall (Fig. 1).
- Pierce the rubber grommet in the angled mounting bracket and insert the lines. Attach the angled mounting bracket to the mounting plate (Fig. 2) and press it closed (Fig. 3).
- Attach the sensor unit to the angled mounting bracket (Fig. 4) and connect it according to the wiring diagram (Fig. 15 to 17).
- Push the sensor unit up into the angled mounting bracket and snap it in place (Fig. 5).
- Slide the cover over the sensor unit and place the cover on the angled mounting bracket (Fig. 6).

### Ceiling mounting

- Fasten the mounting plate to the ceiling (Fig. 8).
- Pierce the rubber grommet in the angled mounting bracket and insert the lines. Attach the angled mounting bracket to the mounting plate (Fig. 2) and press it closed (Fig. 3).
- Attach the sensor unit to the angled mounting bracket (Fig. 11) and connect it according to the wiring diagram (Fig. 15 to 17).
- Push the sensor unit up into the angled mounting bracket and snap it in place (Fig. 12).
- Break out the drainage opening in the cover (Fig. 13).
- Slide the cover over the sensor unit and place the cover on the rear of the angled mounting bracket (Fig. 13).



### Note on parallel mounting (Fig. 17)

- Do not exceed the maximum connected load of a motion detector.
- Connect all motion detectors to the same phase.
- Up to 10 motion detectors can be connected in parallel.
- The cable length between two motion detectors must not exceed 50 m.

### LED function

Normal operation	LED off
Test operation	LED lights up during movement
Continuously ON/OFF	LED lights up
Teach-in / day mode	The LED flashes five times. Teach-in or day mode is activated.
Remote control	LED flashes

### Restrict detection field

The detection field can be restricted using the covering panel, e.g. to suppress sources of interference.

- Slide the cover down (Fig. 21).
- Loosen the lens screws on the sensor unit (Fig. 22).
- Push the lens in the direction of the angled mounting bracket (Fig. 23).
- Remove the lens (Fig. 24).
- If necessary, cut out the covering panel with scissors along the marked lines (Fig. 25).
- Place the covering panel in the lens and mount the lens again in reverse order.

## Technical data

Rated voltage:	230 V~ (50 / 60 Hz)
Connected load	
HV LED lamps:	typically 200 W
Light bulbs:	2000 W
Fluorescent lamps, uncompensated:	1000 VA ( $\cos \phi = 0.5$ )
Fluorescent lamps, parallel-compensated:	500 W (45.6 $\mu$ F)
Fluorescent lamps, row-compensated:	900 W
Setting controller	
Brightness value:	2 to 1000 lx
Delay time:	5 seconds to 15 minutes
Protection level:	IP54
Connection cross section:	Fig. 20
Ambient temperature:	-25 °C to +55 °C
Dimensions WxHxD in mm	
without lens	87 x 87 x 85
with lens	87 x 113 x 85

## Troubleshooting

### Motion detector does not switch on

- Cause 1: Ambient brightness is higher than the brightness threshold set.  
→ Increase brightness threshold with twilight setting controller.
- Cause 2: Lamp defective.  
→ Replace the lamp.
- Cause 3: Fuse defective.  
→ New fuse, check connection if necessary.
- Cause 4: Detection range not set.  
→ Re-adjust it.

### Motion detector does not switch off

- Cause 1: Continuous movement in the detection range.  
→ Check the range and readjust or cover if necessary.

Cause 2: Switched light is within the detection range and switches on again due to a change in temperature.  
→ Change or cover range.

Cause 3: Switched light is in continuous ON operation (LED on).  
→ Deactivate continuous light operation.

### Motion detector always switches ON and OFF

Cause 1: Switched light is in the detection range.  
→ Change or cover range and increase distance.

Cause 2: Animals are moving within the detection range.  
→ Change or cover range.

### Motion detector switches on although this is not desired

Cause 1: Wind moves trees and shrubs in the detection range.  
→ Restrict detection range.

Cause 2: Detection of cars on the road.  
→ Restrict detection range.

Cause 3: Sunlight falls on the lens.  
→ Attach in a protected manner or change the range.

Cause 4: Sudden change in temperature due to weather (wind, rain, snow) or air from fans or open windows.  
→ Change range, relocate installation location.

Cause 5: Anti-glare active.  
→ Manual switching via switch.  
→ No movement within the set delay time + 60 seconds (glare protection).

Cause 6: Motion detector near WLAN or other radio sources.  
→ Install at a distance of least 2 m from the radio source

### LED flashes 1 x every 15 seconds

Cause: Too large load connected.  
→ Reduce load or use relay.

## IR remote control PIR 3

### Battery safety instructions

**DANGER!** Batteries can be swallowed. This can lead directly to death by suffocation. Dangerous substances can cause severe internal burns leading to death within 2 hours.

Keep new and used batteries away from children.

Do not use any equipment on which the battery compartment cannot be closed reliably or keep it away from children.

If you suspect that a battery has been swallowed or is in any orifice of the body, seek medical attention immediately.

**WARNING!** Improper handling of batteries may result in an explosion, fire or burns due to leakage.

Do not heat batteries or throw batteries into fires.

Do not reverse the polarity, short-circuit or recharge batteries.

Do not deform or disassemble batteries.

Only replace batteries with the same or equivalent type.













Remove flat batteries immediately and dispose of them in an environmentally sound manner.

### Intended use



- Infrared remote control for manual operation and setting of motion detectors.

## Operation

Table 1: IR remote control function buttons

Button	Function
<b>Auto</b>	Automatic mode
<b>ON</b> 	Continuously On for 2 hours
<b>OFF</b> 	Continuously Off for 2 hours
<b>Mas./ Slave</b>	no function
	no function
<b>25 %</b> , <b>50 %</b> , <b>75 %</b> , <b>100 %</b>	Setting the detection sensitivity
<b>- 5 %</b>	Fine adjustment of detection sensitivity in 5 % decrements until minimum range is reached
<b>+ 5 %</b>	Fine adjustment of detection sensitivity in 5 % increments until maximum range is reached
<b>1 sec</b> 	Short-term operation
<b>30 sec</b> 	Delay time 30 seconds
<b>2 min</b> 	Delay time 2 minutes
<b>5 min</b> 	Delay time 5 minutes
<b>30 min</b> 	Delay time 30 minutes
<b>START</b>  / <b>STOP</b> 	Set individual delay time, max. 60 minutes
	Night mode switch-on threshold approx. 2 lx
	Switch-on threshold approx. 10 lx
	Switch-on threshold approx. 150 lx

**Tabelle 1: IR remote control function buttons**

Button	Function
	Day mode, switches regardless of brightness level
TEACH 	Save ambient brightness as switch-on threshold
TEST	Test mode (day mode, 1 second delay time). Test mode is switched on for 10 minutes, then the motion detector switches back to automatic mode. The <b>TEST</b> button can be used to switch to automatic mode at any time.
RESET	The switch-on threshold and delay time are set to the values set at the setting controller.

## Start-up

### Inserting the battery



**Observe battery safety instructions.**

- Keep battery and device contacts free of grease.
- Insert the enclosed battery with the correct polarity (see imprint on IR remote control).

## Technical data

Rated voltage: DC 3 V  
Battery type: 1×lithium CR 2025

## Battery disposal



**Remove flat batteries immediately and dispose of them in an environmentally sound manner. Do not dispose of batteries together with household waste. Local authorities provide information about environmentally sound disposal. The end consumer is legally obliged to return used batteries in accordance with statutory requirements.**

## Warranty

The warranty is provided in accordance with statutory requirements via the retailer.

Please submit or send faulty devices postage paid and with a fault description to your sales representative (retailer / installation company / electronics retailer). They will forward the devices to the Gira Service Centre.