

## Ethernet2Dali

DALI sensors

### DALI2 PIR CLS SENSORHEAD 10M

Multi-sensor

#### Product description

- Sensor developed to work with the latest DALI specification
- Monitoring of ambient light and motion detection
- Remote control interface allowing infrared remote control interaction
- Individual adjustment of the parameters with configuration software
- Power supply via DALI line
- Shutter for preventing movement detection in one direction included
- Small dimensions allowing easy and inconspicuous integration in luminaries
- Wide range of accessories allowing extended application range
- 5-year guarantee

#### Housing properties

- Casing: polycarbonate, white
- Type of protection up to IP66

#### Note

- Our DALI2 family sensors are developed according to DALI Standard EN 62386-101 Ed.2, also known as DALI-2. To be able to use the sensor in such installation, an application controller is necessary. List of approved application controller can be found on our WEB page [„Application\\_controllers\\_MSensor\\_G3.pdf“](#)



Fig. 1



Fig. 2

**Technical data**

Supply via	DALI
Supply voltage <sup>①</sup>	9.5 – 22.5 V
Current consumption (no LED)	max. 8 mA
Current consumption (with LED)	max. 9 mA
Mounting height	5 – 10 m
Mounting hole diameter	23 mm
Cover size of luminaire	0.75 – 4.00 mm
Detection angle for PIR detection (tagential / radial)	72° / 44°
Detection angle for light measurement	30° – 40°
Detection range for light measurement <sup>②</sup>	0.5 – 2,000 lx
Min. temperature difference between ambient temperature and detected object	± 4 °C
Ambient temperature ta	-20 ... +50 °C
tc	60 °C
Storage temperature	-25 ... +60 °C
Housing material body	PC polycarbonate
Housing material lens	PE polyethylene
Housing colour body	White (similar to RAL 9010)
Housing colour lens	White
Type of installation	Fitted in luminaires
Type of protection <sup>③</sup>	Up to IP66

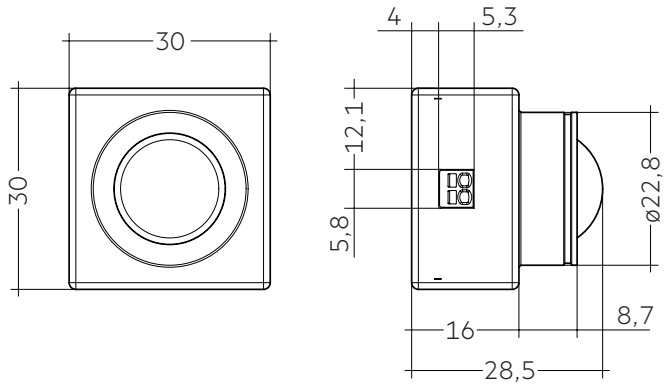

Fig. 1

**Ordering data**

Type	Article number	Figure	Dimensions L x W x H	Packaging carton	Weight per pc.
DALI2 PIR CLS SENSORHEAD 10M Luminaire Installation	B07004003	1	30 x 30 x 28.5 mm	10 pc(s).	0.013 kg

85@&A BH%&A G9B GCF!G  
 A ci bh]b[ Vcl zcf W]]b[

① Uin acc. IEC 62386-101.

② The measured value at the sensor head corresponds to approx. 3 to 6,300 lux on the surface measured.

③ Depending on the installation type up to IP66 for more details see chapter 3.7.

## Accessories SENSOR HOUSING

### Product description

- Mounting frame for wired MSensor G3 SFI 30 PIR 10DPI WH sensors allowing direct mounting to the ceiling
- Available as configured bundle with sensor and as sensor-free version
- Easy „click in“ installation of the sensor
- IP20
- Casing: polycarbonate, white
- UV stabilized plastic
- MSensor G3 SFI 30 PIR 10DPI WH is powered via DALI circuit
- Mounting kit with screws and decorative plugs
- 0.5 mm wiring for the sensor
- Two 3 x 1.5 mm<sup>2</sup> clamps with cable management (2 entry points on oppsite sides)
- Including gasket for ideal IP protection
- Casing passed glow wire test with 850 °C according to EN 61347-1

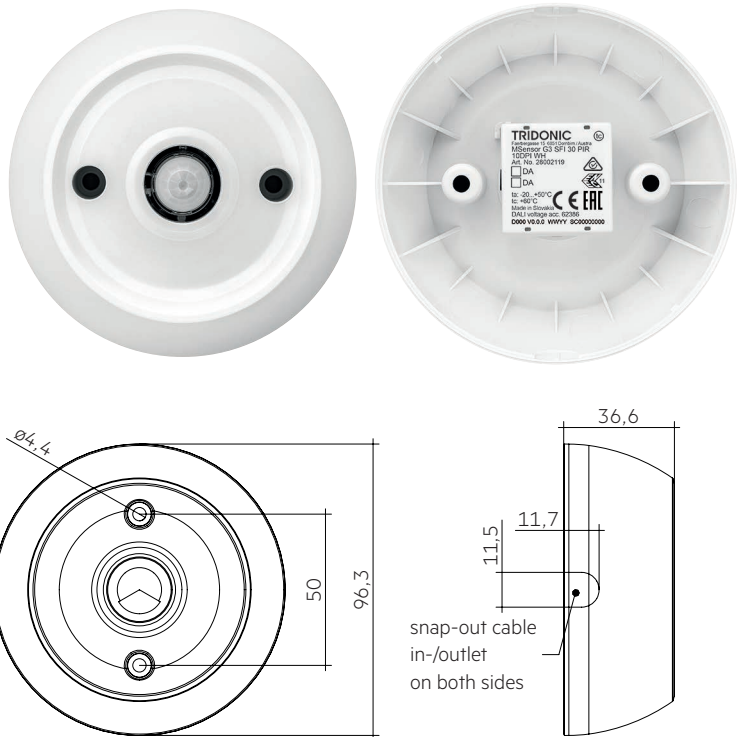

### Ordering data

Type	Article number	Packaging carton	Weight per pc.
DALI2 MNT 10M SENSOR-S	B07004005	57 pc(s).	0.054 kg

## Accessories

### SENSOR HOUSING

#### Product description

- Mounting frame for wired MSensor G3 SFI 30 PIR 10DPI WH sensors allowing direct mounting to the ceiling
- Available as configured bundle with sensor and as sensor-free version.
- Easy „click in“ installation of the sensor
- IP66
- Casing: PC polycarbonate, white
- UV stabilized plastic
- MSensor G3 SFI 30 PIR 10DPI WH is powered via DALI circuit
- Optional shutter for reduction of movement detection area allowing to decrease the movement detection area from 360° to 240°
- Mounting kit with screws and decorative plugs
- Including gasket for ideal IP protection
- Casing passed glow wire test with 850 °C according to EN 61347-1

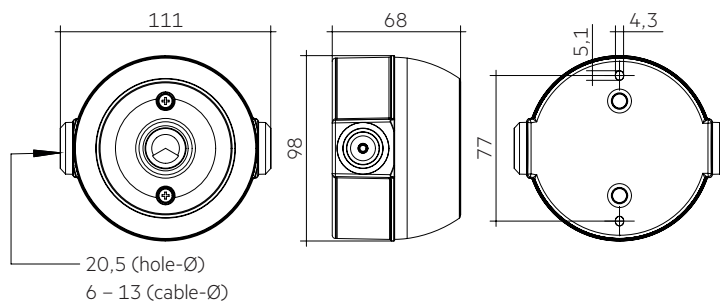

#### Ordering data

Type	Article number	Packaging carton	Weight per pc.
DALIZ MNT 10M IP66 SEN-S	B07004006	26 pc(s).	0.105 kg

## 1. Standards

EN/IEC 61347-2-11:2001 EN  
55015:2013  
EN 61000-3-2:2014 Part 3-2  
EN 61000-3-3:2013 Part 3-3  
EN 61547:2009  
EN 62386-101 Ed.2  
EN 62386-103 Ed.1  
EN 62386-301  
EN 62386-303  
EN 62386-304

## 2. Common

LMS DALI2 PIR CLS 10M SENSOR is one of the new generation of our sensors.  
With this Sensor, the customer gets a small sized sensor for medium height applications and a protection against environmental influence up to IP66.

This sensor provides measurement of ambient light, motion detection via PIR sensor and IR remote control input as well as a LED output for signalisation.  
DALI2 PIR CLS 10M SENSOR is created for following main applications:  
Medium height buildings such as

- Factory buildings
- Storage buildings and warehouses
- Corridors, passages und Garages
- Outdoor applications

## 3. Installation

- The MSensor must not be connected to the mains. It is supplied directly via the DALI power supply.
- DALI is not SELV.  
The installation instructions for mains voltage therefore apply.
- Please ensure that the detection range of the sensor lies in the lighting area of the controlled luminaires.
- Please ensure that the detection ranges of the sensors do not overlap.  
This may have influence to the lighting control.
- When installed at a height other than the recommended installation height, the presence sensor might show different characteristics. When mounted at a higher level, its sensitivity is reduced.  
If mounted at a lower level, its range is reduced.
- Heaters, fans, printers and copiers located in the detection zone may cause incorrect presence detection.
- Avoid direct illumination of the light source on the sensor including housing.

### 1.1 DALI note



Tridonic MSensor G3 family sensors are developed according to DALI Standard EN 62386-101 Ed.2, also known as DALI-2.  
To be able to use the sensor in such installation, an application controller is necessary.  
List of approved application controller can be found on our WEB page „[Application controllers MSensor G3.pdf](#)“

### 1.2 Glow wire test

according to EN 61347-2-11 passed for temperatures up to 750°

C.

### 3.1 Wiring

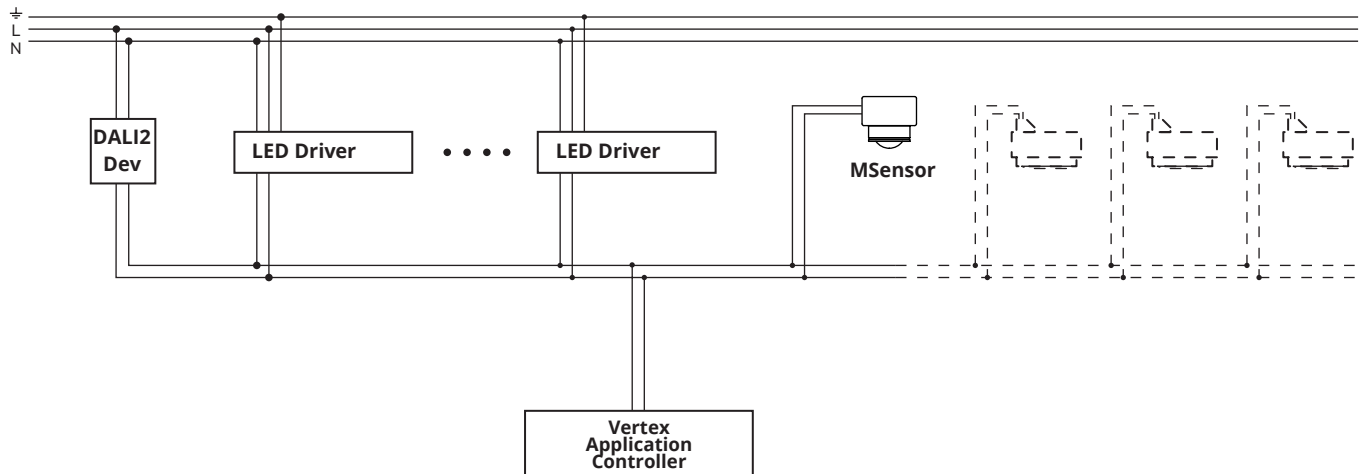

### 3.2 Wiring type and cross section

The wiring can be solid wire or stranded wire with a cross-section for solid wire of 0.14 mm<sup>2</sup> to 0.5 mm<sup>2</sup> and a cross-section for stranded wire of 0.2 mm<sup>2</sup> to 0.5 mm<sup>2</sup>.

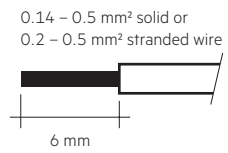

3.3.2 Installation in Sensor housing MNT 10M IP66 SEN-S  
 To ensure the right IP protection please read chapter 3.6 Gasket.

Step 1: Cover placed on base plate

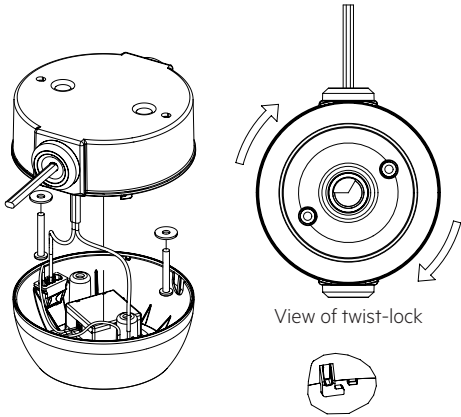

View of twist-lock

Step 2: Cover locked

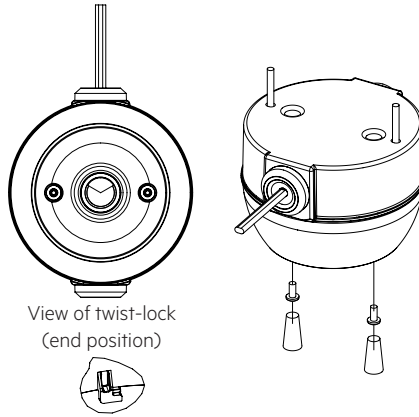

View of twist-lock (end position)

Mount base plate. Feed cable (cable diameter: 6 – 13 mm) of the lateral grommets into the installation terminals.

After the cover is loosely mounted on the base plate, insert and tighten the 2 screws. In the last step insert in the sealing plugs.

3.3.3 Installation in Sensor housing MNT 10M SENSOR-S  
 To ensure the right IP protection please read chapter 3.6 Gasket.

Exploded view

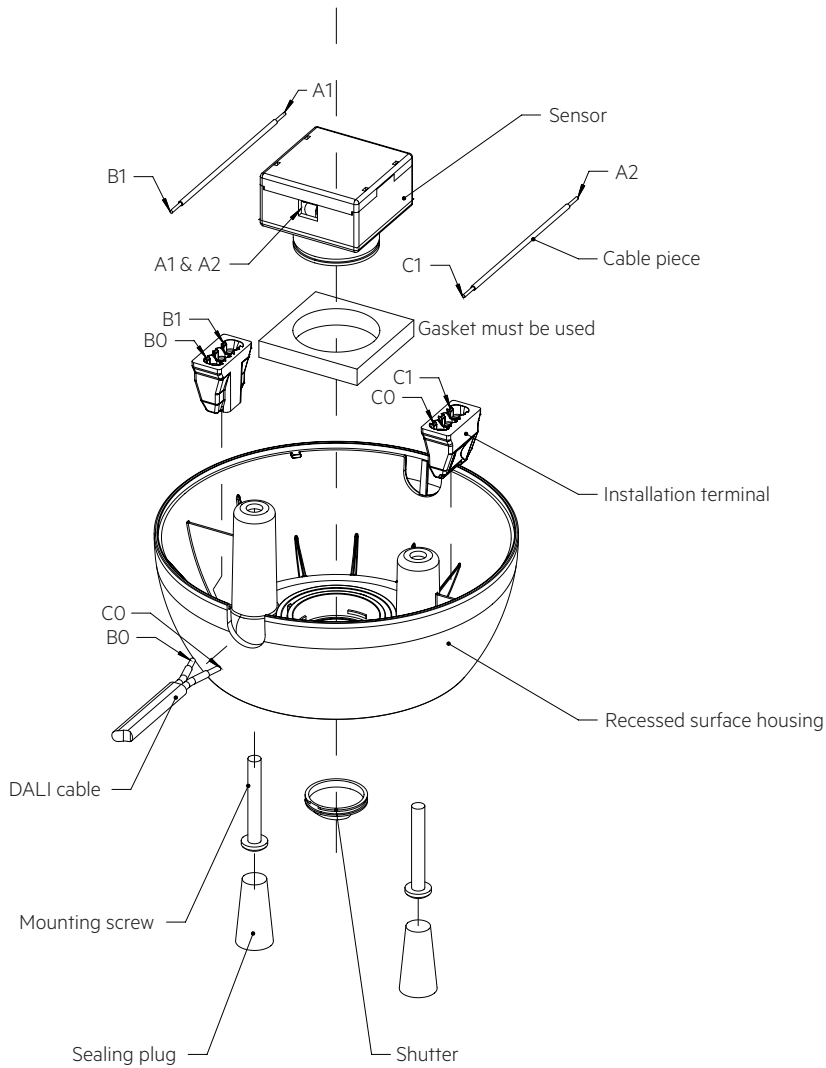

Top view

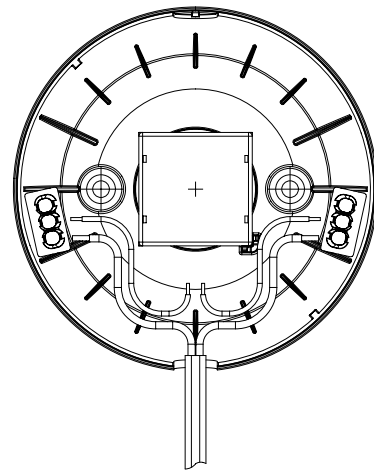

### 3.4 Detection area covers

Included in each Sensor there are two detection area covers. Each of these cover can be attached to the front of the sensor.

The 120° cover offers the possibility to reduce the detection area of PIR Sensor by 120° or 1/3 of its detection area.

There is no influence of detection area of light measurement or IR receiver by this cover.

0° cover is made only for aesthetical reasons to give the sensor a flush surface. It is not needed for proper operation of the sensor.

Type of material: PC polycarbonate  
 Colour: transparent  
 Surface finish: polished

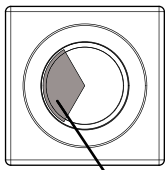
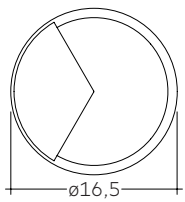
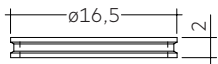

Attach the detection area cover to the sensor by inserting it into the corresponding groove at the front of the sensor.

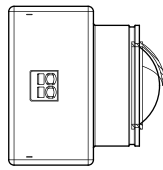

Area which is masked by the shutter:

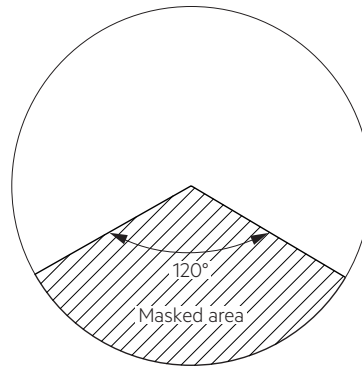
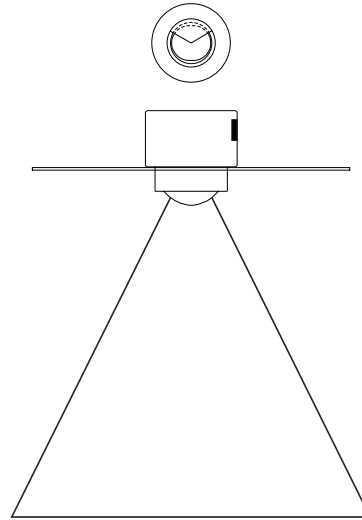

### 3.5 Mounting ring

Included in each Sensor mounting kit MNT 10M IP66 SEN-S there is a mounting ring. This Ring allows to mount the sensor into a luminaire in an easy and visual attractive way.

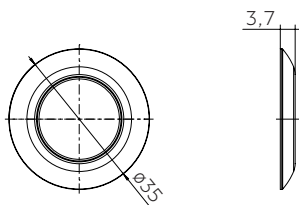

## 4. Sensor function

### 4.1 Motion detection

For motion detection PIR technology is used. PIR Lens is made to detect moving people in working areas such as warehouses, storage buildings and similar working areas with the following performance criteria:

- Ceiling height from 5 up to 10 m
- Movement of human body (increment  $\geq 1.5$  m), no slight motion (no sitting person)
- Movement  $\geq 1.0$  m/s for mounting heights up to 7.5 m
- Movement  $\geq 1.5$  m/s for mounting heights up to 10.0 m

### 4.2 Detection area

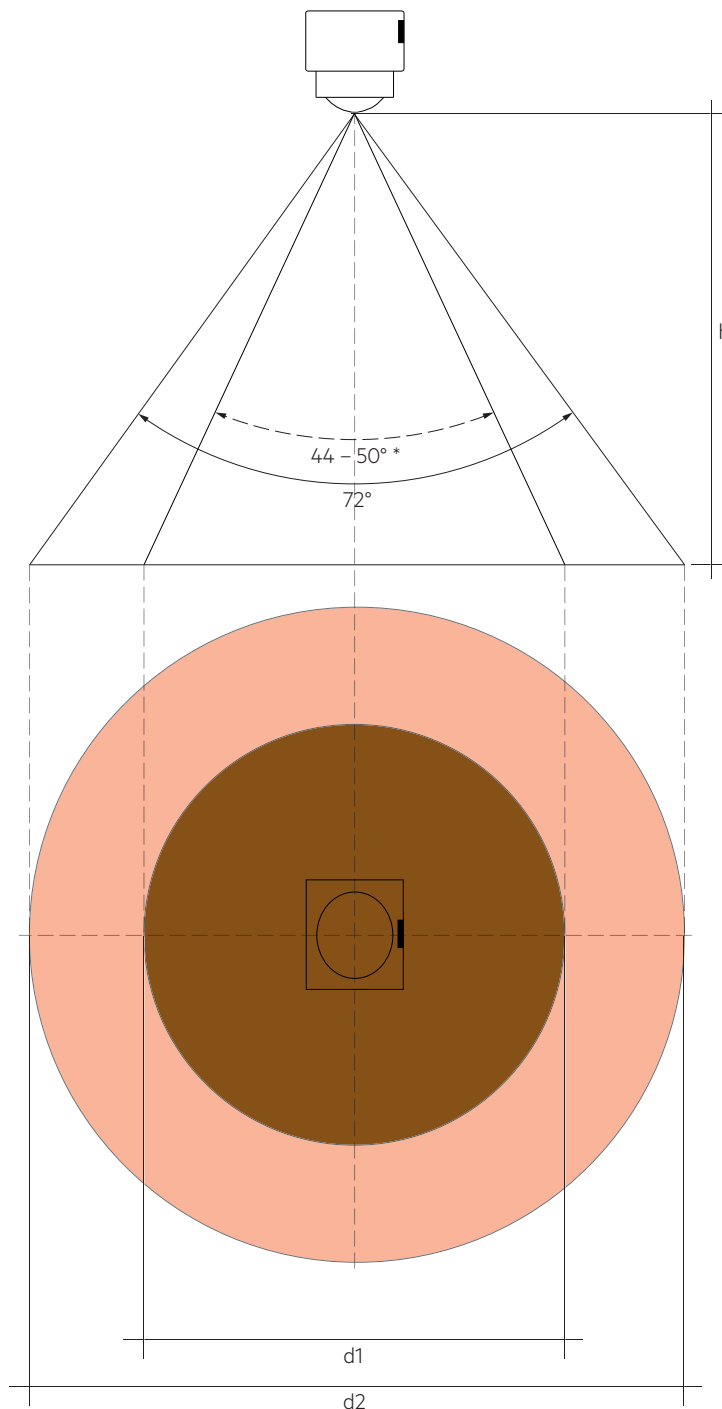

Reaction time of the sensor (time between motion detected and event information send to DALI Bus) is  $\leq 25$  ms.

The reaction time of the system can be extended by factors such as the amount of data on the bus, the number of connected devices or the control device used (Application Controller).

The point at which the light responds must therefore not be equated with the outer detection range.

h = Height	d1 = Radial	Radial detection angle	d2 = Tangential (72°)
5 m	4.6 m	50°	7.0 m
6 m	5.6 m	50°	8.4 m
7 m	6.6 m	50°	9.8 m
8 m	7.4 m	50°	11.2 m
9 m	7.2 m	44°	12.6 m
10 m	8.0 m	44°	14.0 m

Schematic illustration of radial / tangential movements:

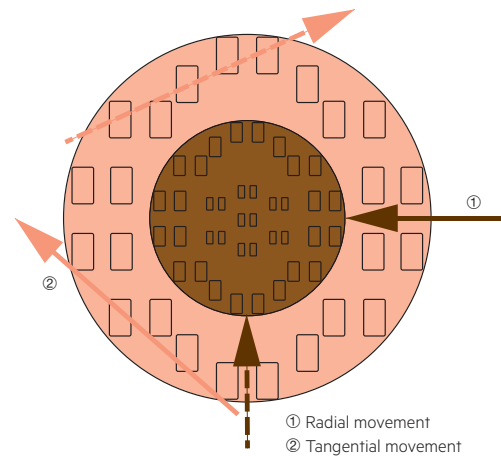

\* The detection angle for the radial movement varies with the different mounting height between 44 and 50°.

Detection example at 5 m mounting height:

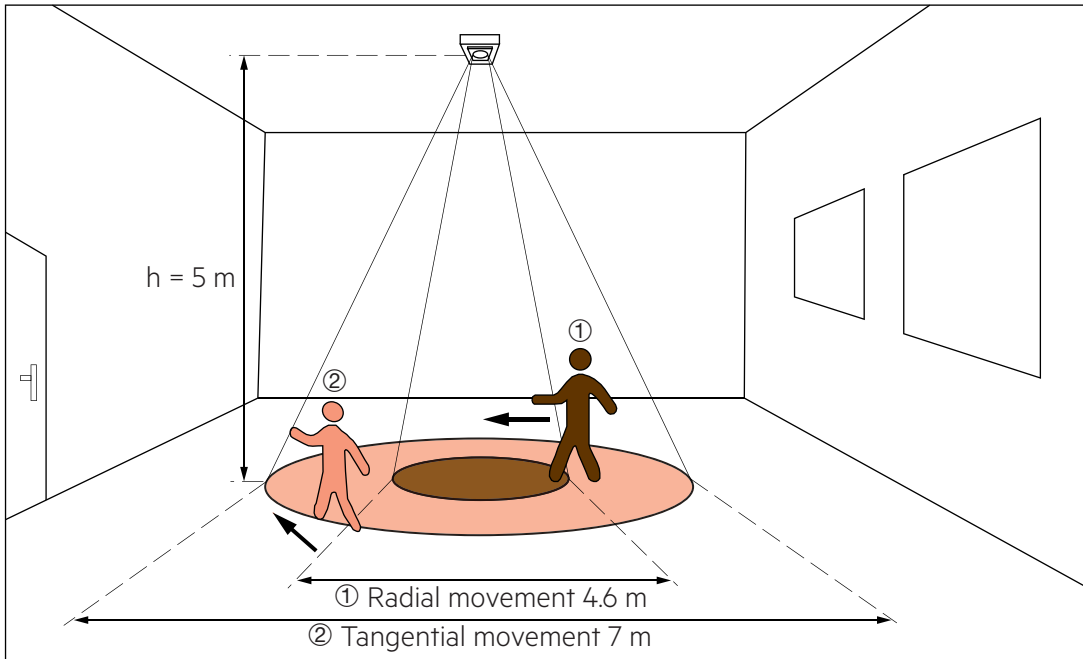

### 4.3 Light measurement

The light measurement has a cone-shaped detection area with a half angle of approximately 20° in x-direction and 15° in y-direction.

The following operating modes can be set for lighting control via the mobile App configuration software:

Active	Constant light control is active.
Inactive	Constant light control is deactivated. The lighting is switched on an adjustable light value.

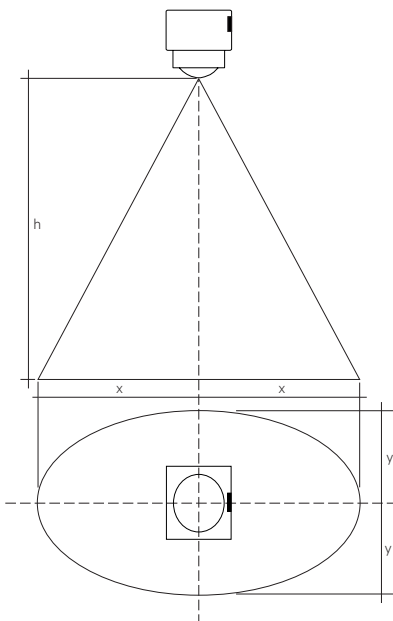

h	dx	dy
5.0 m	3.6 m	2.7 m
7.5 m	5.5 m	4.0 m
10.0 m	7.2 m	5.4 m

The measurement range is between 0.5 and 2000 lx. Measured at the sensor head.



To be able to measure values < 5 lx in an accurate way it is needed to change integration time of light sensor to 800 ms. Integration time of light sensor is set to 100 ms by default. For values > 5 lx there is no difference in between these measurements.

### 4.4 Status LED's

There is a LED built in to indicate different status information to the user. This LED is controlled from the sensor itself.



To not have any influence from LED to the light measurement, LED is disabled while light sensor is measuring by default.

## 5. Miscellaneous

### 5.1 Disposal of equipment



Return old devices in accordance with the WEEE directive to suitable recycling facilities.