

SOFTSTARTER TYPE PSTX

Fieldbus communication

Anybus CompactCom BACnet MS/TP
and BACnet IP



PREPARED 2024-07-03	STATUS Approved	SECURITY LEVEL Public		
RELEASED 2024-07-27	DOCUMENT KIND Manual			
OWNING ORGANIZATION Smart Power	DOCUMENT ID. 1SFC132381M0201	REV. C	LANG. en	PAGE 1/27

Contents

- 1. BACnet MS/TP and BACnet IP 4**
 - 1.1. Terminology 4
 - 1.2. Topology of the BACnet/IP and BACnet MS/TP network.....5
 - 1.3. Anybus module BACnet/IP 6
 - 1.3.1. Front view 6
 - 1.3.2. Network Status LED 6
 - 1.3.3. Module Status LED7
 - 1.3.4. Link/Activity LED.....7
 - 1.4. Anybus module BACnet MS/TP 8
 - 1.4.1. Front view 8
 - 1.4.2. Network Status LED 8
 - 1.4.3. Module Status LED 9
 - 1.4.4. BACnet Connector 9
 - 1.5. Software compatibility 9
- 2. Start-up.....10**
 - 2.1. Required Settings10
 - 2.2. Communication Fault 11
 - 2.3. Softstarter Control 11
 - 2.4. Restore Default Object Names 11
 - 2.5. Mailbox Read/Write 12
 - 2.6. Supported Services 12
 - 2.6.1. Change of Value.....12
 - 2.6.2. Time Synchronization.....12
 - 2.6.3. Device Communication Control13
 - 2.6.4. Alarms13
 - 2.7. Protocol Implementation Conformance Statement (PICS) 13
 - 2.8. BACnet Objects 16
 - 2.8.1. Device Object Instance Summary16
 - 2.8.2. Binary Value Object Instance Summary17
 - 2.8.3. Analog Value Object Instance Summary 20
- 3. Additional Information.....27**
 - 3.1. Listing of related documents.....27
- 4. Contact us27**

STATUS	SECURITY LEVEL	DOCUMENT ID.	REV.	LANG.	PAGE
Approved	Public	1SFC132381M0201	C	en	2/27

Cyber Security Legal Disclaimer

The Anybus CompactCom BACnet IP product is designed to be connected to and to communicate information and data via a network interface. It is your sole responsibility to provide and continuously ensure a secure connection between the product and your network or any other network (as the case may be). You shall establish and maintain any appropriate measures (such as but not limited to the installation of firewalls, application of authentication measures, encryption of data, installation of anti-virus programs, etc.) to protect the product, the network, its system and the interface against any kind of security breaches, unauthorized access, interference, intrusion, leakage and/or theft of data or information. ABB Ltd and its affiliates are not liable for damages and/or losses related to such security breaches, any unauthorized access, interference, intrusion, leakage and/or theft of data or information.

Risk Mitigation and Secure Deployment

The idea is to create defence-in-depth protection for each network by allocating firewall solutions to the front of internal trusted networks of each network by manage firewalls, their configurations and access rules. The softstarter must be positioned in a trusted network, strictly limited and in a hosted portion of a network or control system. Configure firewalls according to the principle of denying everything that is not needed nor used. For secure remote access, use a VPN connection with an encryption layer to create a secure channel over an insecure network. It is recommended to implement a rate limiter either at device or network level. For more information regarding cyber security and risk mitigation, download the document [Cyber security for ABB drives](#) from the ABB library.



Information

The Anybus CompactCom BACnet IP product uses the default UDP BACnet port 47808 (0xBAC0). This port must be opened in firewall to allow mandatory BACnet traffic.

STATUS	SECURITY LEVEL	DOCUMENT ID.	REV.	LANG.	PAGE
Approved	Public	1SFC132381M0201	C	en	3/27

1. BACnet MS/TP and BACnet IP

BACnet is a standard data communication protocol that enables interoperability between different building systems (e.g. fire, security, lighting, HVAC, elevator, etc.) and devices in building automation and control applications. It enables data sharing among different types of devices from a broad set of suppliers.

The BACnet protocol is a fieldbus protocol that provides full control and status information of the softstarter, reading as well as writing of parameters. Through the fieldbus it is possible to start and stop the motor, read out currents and frequency, get information about protections, warnings, faults and much more. See chapter 8 in the Installation and commissioning manual, document 1SFC132081M0201 for fieldbus related settings.

1.1. Terminology

The following terminology are mentioned in the manual:

Objects

BACnet object is a logical representation used in the BACnet protocol. It can be used to represent many different aspects of a control system.

Services

Information exchange between objects is provided by services. Services are used to perform reads, writes, and I/O. The object that provides the service is a server and the object that requests the service is the client. Most objects can be both a server and a client, depending on the system's needs.

Properties

A property contains information about an object. Objects may contain a large collection of properties, some of which may be required for the specific object type. Every object in BACnet must have at least the following three properties:

- Object identifier
- Object name
- Object type

STATUS	SECURITY LEVEL	DOCUMENT ID.	REV.	LANG.	PAGE
Approved	Public	1SFC132381M0201	C	en	4/27

1.2. Topology of the BACnet/IP and BACnet MS/TP network

The below examples show the allowable topologies for BACnet/IP and BACnet MS/TP networks. The example in Figure 1 works for BACnet/IP. The example in Figure 2 works for both BACnet/IP and BACnet MS/TP. We use BACnet/IP in the examples.

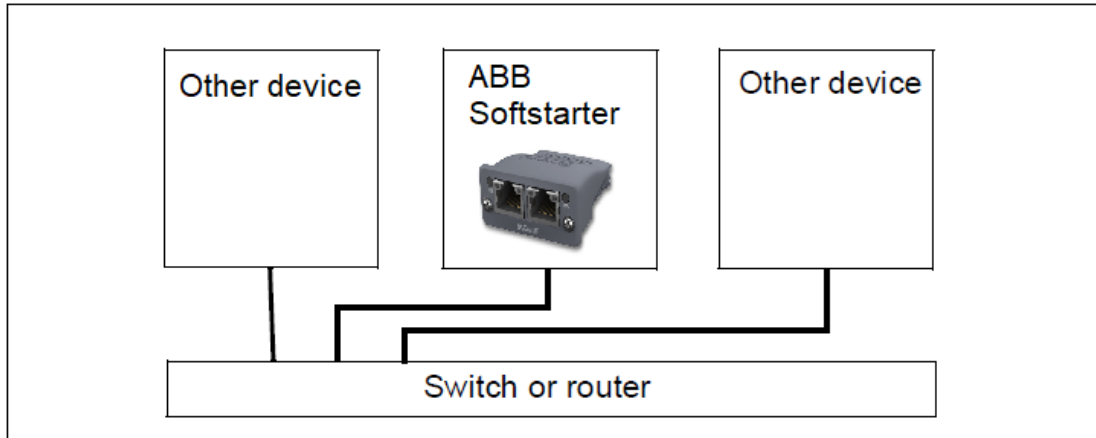

Figure 1. Allowed topology for BACnet/IP

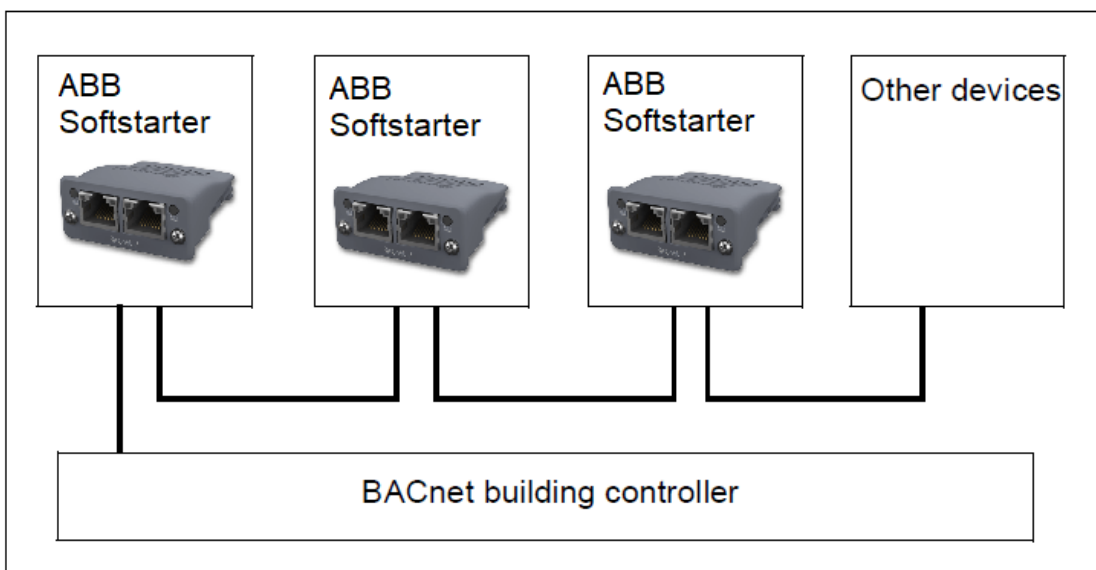

Figure 2. Allowed topology for both BACnet/IP and BACnet MS/TP

1.3. Anybus module BACnet/IP

The Anybus CompactCom BACnet/IP module is connected to the COM 1 interface on the PSTX softstarter. It can be used to control the softstarter, get status information, and to configure softstarter parameters.



1.3.1. Front view

Description of Ports and LEDs.

#	Item
1	Network Status LED
2	Module Status LED
3	Ethernet Interface, Port 1
4	Ethernet Interface, Port 2
5	Link/Activity Port 1
6	Link/Activity Port 2

1.3.2. Network Status LED

A test sequence is performed on this LED during startup.

LED State	Indication/Description
Off	No power or no IP address
Green	Online, one or more BACnet messages have arrived Module has active COV subscriptions At least one value object has one or more events enabled
Green, flashing	Online, waiting for first BACnet message.
Red	Duplicate IP address, FATAL error
Red, flashing	Connection timeout. No BACnet message has been received within the configured “process active timeout” time. A COV or Alarm/Event notification could not be sent to its recipient.

1.3.3. Module Status LED

A test sequence is performed on this LED during startup LED State	Indication/Description
Off	No power
Green	Normal operation
Red/green, alternating	Firmware update from file system in progress
Red	Major fault
Red, flashing	Recoverable fault(s)

1.3.4. Link/Activity LED

LED State	Indication/Description
Off	No link, no activity
Green	Link (100 Mbit/s) established
Green, flickering	Activity (100 Mbit/s)
Yellow	Link (10 Mbit/s) established
Yellow, flickering	Activity (10 Mbit/s)

1.4. Anybus module BACnet MS/TP

The Anybus CompactCom BACnet MS/TP module is connected to the COM 1 interface on the PSTX Softstarter. It can be used to control the Softstarter, get status information, and to configure softstarter parameters.



1.4.1. Front view

Description of Ports and LEDs.

#	Item
1	Network Status LED
2	Module Status LED
3	BACnet connector

1.4.2. Network Status LED

A test sequence is performed on this LED during startup.

LED State	Indication/Description
Off	No power
Green	Online, one or more BACnet messages have arrived Module has active COV subscriptions At least one value object has one or more events enabled
Green, flashing	Online, waiting for first BACnet message.
Red	FATAL error
Red, flashing	Connection timeout. No BACnet message has been received within the configured "process active timeout" time. A COV or Alarm/Event notification could not be sent to its recipient.

1.4.3. Module Status LED

A test sequence is performed on this LED during startup.

LED State	Indication/Description
Off	No power
Green	Normal operation
Red	Major fault
Red, flashing	Recoverable fault(s)

1.4.4. BACnet Connector

Pin Number	Name	Description
1	Common	Signal common
2	Data-	Negative RS485 RxD/TxD
3	Shield	Cable shield
4	Data+	Positive RS485 RxD/TxD
5	(not used)	

1.5. Software compatibility

BACnet is supported from PSTX_CB v1.39.8.

STATUS	SECURITY LEVEL	DOCUMENT ID.	REV.	LANG.	PAGE
Approved	Public	1SFC132381M0201	C	en	9/27

2. Start-up

This chapter contains information on configuring the softstarter with the BACnet IP and BACnet MS/TP module.

2.1. Required Settings

Before the BACnet fieldbus can be taken into operation the following parameters must be set in the softstarter:

- Parameter 12.02 FB interface connector is set to Anybus.
- Parameter 12.33 Fieldbus BACnet Device Instance is set to a value that is under the default value. This BACnet Device Instance is unique to the device across the network that comprise the BACnet system. It is with the Device Instance that messages are exchanged between BACnet devices. The valid numeric values are between 0 and 4194302. The default value is 4194303 which is not a valid value and means the communication will then not work.

For **BACnet IP:**

- Parameter 12.05 Fieldbus IP address is set to the IP address for this device in the network.
- Parameter 12.34 BACnet FDR (Foreign Device Registration) IP address is set to the IP address of the BACnet IP broadcast management device (BBMD).
- Parameter 12.35 BACnet FDR UDP port is set to the UDP port number of the BBMD.
- Parameter 12.36 BACnet FDR time interval is set to the registration time interval in seconds to keep a live connection to the BBMD.

For **BACnet MS/TP:**

- Parameter 12.04 Fieldbus address (MAC address) is set to a unique ID within its own network. The valid numeric values are between 0 and 127.



Information

After changing any of the communication parameters it is needed to perform a power cycle of the device for the parameter values to be taken into effect. Or another way for a communication parameter value change to be taken into effect is to set parameter 12.2 FB interface connector to “None” and then set it back to “Anybus”.

When changing the time through SoftstarterCare or through HMI, it does not affect the time in the BACnet client.

STATUS	SECURITY LEVEL	DOCUMENT ID.	REV.	LANG.	PAGE
Approved	Public	1SFC132381M0201	C	en	10/27

2.2. Communication Fault

BACnet has no built-in feature to detect communication timeout because it is not a synchronous protocol. If communication timeouts are needed, you can use the following parameters to detect timeouts and specify an action if required:

- Parameter 12.03 Fieldbus control set to On to enable the fieldbus failure protection.
- Parameter 19.03 Fieldbus failure out specifies which even group the protection belongs to.
- Parameter 19.04 Fieldbus failure op sets the operation for when the protection is raised.
- Parameter 19.12 Fieldbus failure timeout is set to time in seconds without a message passed to the PSTX for the fieldbus failure protection to be raised.

2.3. Softstarter Control

To enable fieldbus control of the softstarter through BACnet, set the Control-Override-Command (BV18) present-value to 1 (On).

When BACnet is in control, BACnet will override the DI logic of Start/Stop, Motor Heating, Lock Parameters, Emergency Mode, User Defined Trip, and Stand Still Brake. As a safety precaution, switching to local control via the HMI will always have priority over BACnet.



Information

Even if Fieldbus control (parameter 12.03) is set to Off, BACnet can always take control of the softstarter. This parameter is not used to enable softstarter control via BACnet but is still used to enable the fieldbus timeout protection. See section 2.2 Communication Fault for more information.

2.4. Restore Default Object Names

The BACnet object names can be reset to default via the HMI:

1. Start from the **Home** view.
2. Press the **Menu** button.
3. Scroll down to **Settings** and press **Select**.
4. Scroll to **Reset to defaults** and press **Select**.
5. Select the **Reset all parameters** option.
6. Press **Yes** to confirm.



Information

All PSTX parameters will be reset, including the communication parameters. Backup any parameters you wish to save before performing these steps.

STATUS	SECURITY LEVEL	DOCUMENT ID.	REV.	LANG.	PAGE
Approved	Public	1SFC132381M0201	C	en	11/27

2.5. Mailbox Read/Write

The softstarter provides a Mailbox function to access parameters that have not been pre-defined by the protocol. Using the mailbox, any parameter can be read or written. Table 1 describes the use of this function.

PSTX Parameter		BACnet object
Mailbox Parameter	Enter the fieldbus ID of the parameter to access ¹	AV25
Mailbox Data	Writing a value to the Mailbox Data will change the parameter specified in Mailbox Parameter. Reading this object will return the current value of the parameter specified in Mailbox Parameter.	AV26

Table 1. Mailbox function

¹⁾ See section 7.25 in the installation and commissioning manual (document number 1SFC132081M0201) to get the fieldbus ID of each parameter.

2.6. Supported Services

2.6.1. Change of Value

The Change of Value (COV) service allows a client to subscribe to be notified whenever an object has changed its value. The device will send a COV notification to the client every time the value changes for the present-value property.

The analog value objects include a COV_INCREMENT property to specify a minimum change before a COV notification is sent. With a default value of 0, the device will send a notification for even the smallest change.

2.6.2. Time Synchronization

The softstarter supports time and date synchronization via BACNET with both the TimeSynchronization and UTC TimeSynchronization service.

Reading the current date or time is achieved by reading the properties local-date and local-time.



Information

The softstarter has no concept of time zones. This means UTC Time Synchronization and the normal Time Synchronization have the same behavior.

When changing the time through SoftstarterCare or through HMI, it does not affect the time in the BACnet client.

STATUS	SECURITY LEVEL	DOCUMENT ID.	REV.	LANG.	PAGE
Approved	Public	1SFC132381M0201	C	en	12/27

2.6.3. Device Communication Control

The Device Communication Control service enables or disables the BACnet communication. Once disabled, the module will only respond to Device Communication Control and ReinitializeDevice requests.



Information

By default, the password for the Anybus BACnet module is Admin.

2.6.4. Alarms

Alarms are supported with 6 notification class objects (Notification_Class, 0 to 5). The notification class objects contain the list of recipients to receive an alarm as well as a priority.

To register an object to be monitored, set the NOTIFICATION_CLASS property of the desired analog or binary value object to the notification class of your choice. Binary values set the alarm value with the ALARM_VALUE property. Alarms for analog values can utilize the limit properties to alarm when the current value falls outside the LOW_LIMIT and HIGH_LIMIT properties of the monitored object, when LIMIT_ENABLE is true for at least one of the limits.

2.7. Protocol Implementation Conformance Statement (PICS)

Product Description:

The PSTX softstarter is a high-performance softstarter designed for HVAC and refrigeration applications. Product supports native BACnet, connecting to the MS/TP and IP LAN. MS/TP baud rates are supported up to 76.8 kbps. Over BACnet, the softstarter can be fully controlled and monitored as a standard softstarter. In addition, the softstarter’s standard and extension I/O is available over BACnet to the user application.

BACnet Standardized Device Profile (Annex L):

- BACnet Operator Workstation (B-OWS)
- BACnet Advanced Operator Workstation (B-AWS)
- BACnet Operator Display (B-OD)
- BACnet Building Controller (B-BC)
- BACnet Advanced Application Controller (B-AAC)
- BACnet Application Specific Controller (B-ASC)
- BACnet Smart Sensor (B-SS)
- BACnet Smart Actuator (B-SA)

STATUS	SECURITY LEVEL	DOCUMENT ID.	REV.	LANG.	PAGE
Approved	Public	1SFC132381M0201	C	en	13/27

List all BACnet Interoperability Building Blocks Supported (Annex K):

- DS-RP-B** Data Sharing-ReadProperty
- DS-RPM-B** Data Sharing-ReadProperty Multiple
- DS-WP-B** Data Sharing-WriteProperty
- DS-WPM-B** Data Sharing-WriteProperty Multiple
- DS-COV-B** Data Sharing-Change of Value
- DM-DDB-B** Device Management-DynamicDeviceBinding
- DM-DOB-B** Device Management-DynamicObjectBinding
- DM-DCC-B** Device Management-DeviceCommunicationControl
- DM-RD-B** Device Management-ReinitializeDevice
- DM-TS-B** Device Management-Time Synchronization

Segmentation Capability BACnet MSTP:

- Able to transmit segmented messages Window Size: 480
- Able to receive segmented messages Window Size: 480

Segmentation Capability BACnet IP:

- Able to transmit segmented messages Window Size: 1476
- Able to receive segmented messages Window Size: 1476

Standard Object Types Supported:

Object instantiation is static, i.e. objects cannot be created or deleted.

Refer to tables at end of this document for object details.

Data Link Layer Options:

- BACnet IP, (Annex J)
- BACnet IP, (Annex J), Foreign Device
- ISO 8802-3, Ethernet (Clause 7)
- ATA 878.1, 2.5 Mb. ARCNET (Clause 8)
- ATA 878.1, EIA-485 ARCNET (Clause 8), baud rate(s)
- MS/TP master (Clause 9), baud rate(s): 9.6k, 19.2k, 38.4k, 76.8k
- MS/TP slave (Clause 9), baud rate(s): 9.6k, 19.2k, 38.4k, 76.8k
- Point-To-Point, EIA 232 (Clause 10), baud rate(s):
- Point-To-Point, modem, (Clause 10), baud rate(s):
- LonTalk, (Clause 11), medium:
- BACnet/ZigBee (ANNEX O)
- Other:

Device Address Binding:

Is static device binding supported? (This is currently necessary for two-way communication with MS/TP slaves and certain other devices.)

- Yes No

STATUS	SECURITY LEVEL	DOCUMENT ID.	REV.	LANG.	PAGE
Approved	Public	1SFC132381M0201	C	en	14/27

Networking Options:

Router, Clause 6

- BACnet/IP to MS/TP
- BACnet/ ISO 8802-3, Ethernet to MS/TP
- BACnet/IP to BACnet/ ISO 8802-3, Ethernet
- BACnet/IP to BACnet/ ISO 8802-3, Ethernet to MS/TP

Annex H, BACnet Tunneling Router over IP

BACnet/IP Broadcast Management Device (BBMD)

- Does the BBMD support registrations by Foreign Devices? Yes No
- Max BDT (Broadcast Distribution Table)-Entries: -
- Does the BBMD support network address translation? Yes No

Network Security Options:

Non-secure Device - is capable of operating without BACnet Network Security

Secure Device - is capable of using BACnet Network Security (NS-SD BIBB)

- Multiple Application-Specific Keys:
- Supports encryption (NS-ED BIBB)
- Key Server (NS-KS BIBB)

Character Sets Supported:

Indicating support for multiple character sets does not imply that they can all be supported simultaneously.

- ISO 10646 (UTF-8) IBM™/Microsoft™ DBCS ISO 8859-1
- ISO 10646 (UCS-2) ISO 10646 (UCS-4) JIS X 0208

Table 2 summarizes the Object Types/Properties Supported:

Property	Object type	
	Binary value	Analog value
Object Identifier	R	R
Object Name	R, W, P	R, W, P
Object Type	R	R
Present Value	R, W ⁽¹⁾	R, W ⁽²⁾
Status Flags	R	R
Event State	R	R
Out-of-service	R ⁽³⁾	R ⁽³⁾
Units		R ⁽⁴⁾
Property List	R	R

Table 2. Object Types/Properties

R=Read Only, W=Writable, P=Persist

⁽¹⁾ BV10, BV14, BV18, BV28, BV85-BV87, BV92-BV96, BV101, BV103, BV105 are writable

⁽²⁾ AV25, AV26, AV28, AV123, AV124, AV134 are writable

⁽³⁾ Always FALSE

⁽⁴⁾ Always No units (95)

STATUS	SECURITY LEVEL	DOCUMENT ID.	REV.	LANG.	PAGE
Approved	Public	1SFC132381M0201	C	en	15/27

2.8. BACnet Objects

2.8.1. Device Object Instance Summary

Error! Reference source not found. summarizes the Device Objects supported:

Device Object			
Property	Flag	Type	Default value
Object Identifier	R, W	OID	4194303 ⁽¹⁾
Object Name	R, W, P	CharString	Softstarter 4194303 ⁽²⁾
Object Type	R	Enum	DEV (8)
System Status	R	Enum	
Vendor Name	R	CharString	ABB
Vendor Identifier	R	Unsigned	127
Model Name	R	CharString	PSTX
Firmware Revision	R	CharString	1.1
Application Software Revision	R	CharString	
Protocol Version	R	Unsigned	1
Protocol Revision	R	Unsigned	14
Protocol Services Supported	R	BitString	
Protocol Object Types Supported	R	BitString	
Object List	R	Array of OID	
Max APDU Length Accepted	R	Unsigned	1024
Segmentation Supported	R	Enum	No segmentation (3)
Local Time	R	BACnetTime	
Local Date	R	BACnetDate	
APDU Timeout	R, W	Unsigned	10000 ms
Number of APDU Retries	R, W	Unsigned	3
Device Address Binding	R	List of Struct	
Database Revision	R	Unsigned	1
Active COV Subscriptions	R	Array of BAC-netCOVSubscription	
Property List	R	Array of Unsigned	

Table 3. Device objects

Flags: R=Read Only, W=Writable, P=Persist

⁽¹⁾ With this default value, the BACnet communication will not work. Change parameter 12.33 Fieldbus BACnet Device Instance to a value between 0 – 4194302

⁽²⁾ It is recommended to change the default object name

2.8.2. Binary Value Object Instance Summary

Error! Reference source not found. summarizes the Binary Value Objects supported:

Object ID	Object Name	Description ⁽⁵⁾	Present Value Access Type
BV0	RUN-STOP-Monitor-[0=Stop][1=Run]	Softstarter's run status. During run the softstarter can be in ramp mode or bypass mode	R
BV1	<Reserved>		
BV2	Fault-Monitor-[0=OK][1=Fault]	Actual fault status of softstarter	R
BV3	<Reserved>		
BV4	REMOTE-LOCAL-Monitor-[0=Remote][1=Local]	Actual operating mode	R
BV5	Warning-Monitor-[0=OK][1=Warning]	Actual warning status of softstarter	R
BV6	<Reserved>		
BV7	Ready-To-Start-Monitor-[0=Not-Ready][1=Ready]	Actual ready to start status. Is active when a start command will be successful and inactive otherwise	R
BV8	<Reserved>		
BV9	Enable-Monitor-[0=Disabled][1=Enabled]	Actual enable status of softstarter.	
BV10	RUN-STOP-Command-[0=Stop][1=Run]	Command to start softstarter	W
BV11-BV13	<Reserved>		
BV14	Event-Reset-Command-[0=No-Reset][1=Reset]	Command to reset event	W
BV15-BV17	<Reserved>		
BV18	Control-Override-Command-[0=Off][1=On]	Command the softstarter into BACnet Control Override. In this mode, BACnet acquires softstarter control from its normal source. Note that LOCAL mode of the panel has priority over BACnet Control Override	W

Object ID	Object Name	Description ⁽⁵⁾	Present Value Access Type
BV19	Control-Override-Monitor-[0=Off][1=On]	Indicates if softstarter has been placed in BACnet Control Override by writing BV18. In this mode, BACnet acquires softstarter control from its normal source. Note that LOCAL mode of the panel has priority over BACnet Control Override	R
BV20-BV27	<Reserved>		
BV28	Motor-Heating-Command-[0=Off][1=On]	Command to run motor heating. Use AV28 to set the heating capacity in W to be generated in the motor	W
BV29	Motor-Heating-Monitor-[0=Off][1=On]	Actual status of motor heating mode	R
BV30-BV70	<Reserved>		
BV71	In0-Input-Monitor-[0=Off][1=On]	Status of In0 digital input	R
BV72	In1-Input-Monitor-[0=Off][1=On]	Status of In1 digital input	R
BV73	In2-Input-Monitor-[0=Off][1=On]	Status of In2 digital input	R
BV74	1DI0-Input-Monitor-[0=Off][1=On]	Status of 1DI0 external I/O digital input	R
BV75	1DI1-Input-Monitor-[0=Off][1=On]	Status of 1DI1 external I/O digital input	R
BV76	1DI2-Input-Monitor-[0=Off][1=On]	Status of 1DI2 external I/O digital input	R
BV77	1DI3-Input-Monitor-[0=Off][1=On]	Status of 1DI3 external I/O digital input	R
BV78	1DI4-Input-Monitor-[0=Off][1=On]	Status of 1DI4 external I/O digital input	R
BV79	2DI5-Input-Monitor-[0=Off][1=On]	Status of 2DI5 external I/O digital input	R
BV80	2DI6-Input-Monitor-[0=Off][1=On]	Status of 2DI6 external I/O digital input	R
BV81	2DI7-Input-Monitor-[0=Off][1=On]	Status of 2DI7 external I/O digital input	R
BV82	K4-Relay-Monitor-[0=Off][1=On]	Status of K4 relay	R
BV83	K5-Relay-Monitor-[0=Off][1=On]	Status of K5 relay	R

STATUS	SECURITY LEVEL	DOCUMENT ID.	REV.	LANG.	PAGE
Approved	Public	1SFC132381M0201	C	en	18/27

Object ID	Object Name	Description ⁽⁵⁾	Present Value Access Type
BV84	K6-Relay-Monitor-[0=Off][1=On]	Status of K6 relay.	R
BV85	K4-Relay-Command-[0=Off][1=On]	Output state of K4 relay.	W
BV86	K5-Relay-Command-[0=Off][1=On]	Output state of K5 relay.	W
BV87	K6-Relay-Command-[0=Off][1=On]	Output state of K6 relay.	W
BV88	1DO0-Output-Monitor-[0=Off][1=On]	Status of 1DO0 external I/O digital output.	R
BV89	1DO1-Output-Monitor-[0=Off][1=On]	Status of 1DO1 external I/O digital output.	R
BV90	2DO2-Output-Monitor-[0=Off][1=On]	Status of 2DO2 external I/O digital output.	R
BV91	2DO3-Output-Monitor-[0=Off][1=On]	Status of 2DO3 external I/O digital output.	R
BV92	1DO0-Output-Command-[0=Off][1=On]	Output state of 1DO0 external I/O digital output.	W
BV93	1DO1-Output-Command-[0=Off][1=On]	Output state of 1DO1 external I/O digital output.	W
BV94	2DO2-Output-Command-[0=Off][1=On]	Output state of 2DO2 external I/O digital output.	W
BV95	2DO3-Output-Command-[0=Off][1=On]	Output state of 2DO3 external I/O digital output.	W
BV96	Lock-Parameters-Command-[0=No-Lock][1=Lock]	Command to lock parameters.	W
BV97	Event-Monitor-[0=OK][1=Event]	Actual event status of softstarter.	R
BV98	Stop-Monitor-[0=Not-Stopped][1=Stopped]	Actual stop status.	R
BV99	Event-Reset-Monitor-[0=No-Reset][1=Reset]	Actual event reset status of softstarter.	R
BV100	Top-Of-Ramp-Monitor-[0=Not-TOR][1=TOR]	Top of ramp status which is active when softstarter is in bypass mode and inactive otherwise.	R
BV101	Emergency-Mode-Command-[0=Off][1=On]	Command to set the softstarter in emergency mode.	W
BV102	Emergency-Mode-Monitor-[0=Off][1=On]	Actual emergency mode status of softstarter.	R
BV103	User-Defined-Trip-Command-[0=Off][1=On]	Command to trip the user defined protection function.	W

STATUS	SECURITY LEVEL	DOCUMENT ID.	REV.	LANG.	PAGE
Approved	Public	1SFC132381M0201	C	en	19/27

Object ID	Object Name	Description ⁽⁵⁾	Present Value Access Type
BV104	User-Defined-Trip-Monitor-[0=Off][1=On]	User defined protection trip status.	R
BV105	Stand-Still-Brake-Command-[0=Off][1=On]	Command to run stand still brake. Use AV134 to set the stand still brake strength in percent.	W
BV106	Stand-Still-Brake-Monitor-[0=Off][1=On]	Actual status of stand still brake mode.	R
BV107	Refresh-FB-Parameters-[0=Off][1=On]	Restart fieldbus interface to refresh communication parameters.	W

Table 4. Binary value objects

⁽⁵⁾ Property not supported



Information

For Present Value Access Types

R = Read-only

W = Writable

2.8.3. Analog Value Object Instance Summary

Table 5 summarizes the Analog Value Objects supported:

Object ID	Default Object Name	Description ⁽⁵⁾	Min / Max Present Value ⁽⁵⁾	Present Value Access Type
AV0	<Reserved>			
AV1	Mains-Frequency-[Hz]	Mains frequency in Hz.	40, 72	R
AV2	<Reserved>			
AV3	Output-Voltage-[percent]	AC output voltage in percent.	0, 100	R
AV4	Output-Current-[A]	Output RMS current in A.	0, 10 x nominal current	R
AV5	<Reserved>			

Object ID	Default Object Name	Description ⁽⁵⁾	Min / Max Present Value ⁽⁵⁾	Present Value Access Type
AV6	Output-Power-[kW]	Output active power in kW.	0, 10 x nominal power	R
AV7	Operating-Temperature-Range-[degree]	Thyristor temperature in degrees.	0, 150	R
AV8	<Reserved>			
AV9	KiloWatt-Hour-Meter-NR-[kWh]	Softstarter's cumulative active energy usage in kWh. This value is not resettable.	0, 65535999999	R
AV10- AV13	<Reserved>			
AV14	Running-Hours-[h]	Motor's resettable run time.	0, 3.40282347e38	R
AV15	Motor-Temperature-[percent]	Motor temperature in percent.	0, 100	R
AV16- AV17	<Reserved>			
AV18	Active-Event-Code	Top event code which displays most recent event currently active. To identify the event, convert into a hexadecimal value and see section 10.3 in the installation and commissioning manual (document number 1SFC132081M0201).		R
AV19- AV20	<Reserved>			
AV21	Analog-Out-Monitor-[percent]	Output level of Analog output.	0, 100	R
AV22	1A00-Analog-Out-Monitor-[percent]	Output level of 1A00 external I/O Analog output.	0, 100	R
AV23- AV24	<Reserved>			
AV25	Mailbox-Parameter	Parameter number (fieldbus ID) to be used by mailbox function. See section 7.25 in the installation and commissioning manual (document number 1SFC132081M0201) to get the fieldbus ID of each parameter.		W

STATUS	SECURITY LEVEL	DOCUMENT ID.	REV.	LANG.	PAGE
Approved	Public	1SFC132381M0201	C	en	21/27

Object ID	Default Object Name	Description ⁽⁵⁾	Min / Max Present Value ⁽⁵⁾	Present Value Access Type
AV26	Mailbox-Data	Read or write parameter data. See section 2.5 Mailbox Read/Write.		R, W
AV27	<Reserved>			
AV28	Motor-Heating-Capacity-[W]	Set the heating capacity in W to be generated in the motor.	0, 100000	W
AV29- AV31	<Reserved>			
AV32	Output-Current-Range-[percent]	Actual motor current in percent of rated current IE.	0, 1000	R
AV33- AV103	<Reserved>			
AV104	L1-Current-[A]	Phase L1 RMS current in A.	0, 10 x nominal current	R
AV105	L2-Current-[A]	Phase L2 RMS current in A.	0, 10 x nominal current	R
AV106	L3-Current-[A]	Phase L3 RMS current in A.	0, 10 x nominal current	R
AV107	Output-Power-[HP]	Output active power in HP.	0, 10 x nominal power	R
AV108	Apparent-Power-[kVA]	Apparent power in kVA.	0, 10 x nominal power	R
AV109	Reactive-Power-[kVAr]	Reactive power in kVAr.	0, 10 x nominal power	R
AV110	Mains-Voltage-[V]	Mains voltage in V.	0-760	R
AV111	Power-Factor	Power factor.	0-1	R
AV112	Reactive-Energy-[kVArH]	Softstarter's cumulative reactive energy usage in kVArH. This value is not resettable.	0, 65535999999	R
AV113	EOL-Time-To-Trip-[s]	Time until the EOL protection trips.	0, 7200	R
AV114	EOL-Time-To-Cool-[s]	After EOL trip has occurred, this is the time until reset is possible.	0, 7200	R

STATUS	SECURITY LEVEL	DOCUMENT ID.	REV.	LANG.	PAGE
Approved	Public	1SFC132381M0201	C	en	22/27

Object ID	Default Object Name	Description ⁽⁵⁾	Min / Max Present Value ⁽⁵⁾	Present Value Access Type
AV115	Max-Phase-Current-[A]	Max of the three RMS phase currents in [A].	0, 10 x nominal current	R
AV116	Thyristor-Running-Hours-[h]	Thyristor run time in hours. This value is not resettable.	0, 3.40282347e38	R
AV117	Number-Of-Starts	Total number of starts. This value is not resettable.	0, 3.40282347e38	R
AV118	PT100-Temperature-[degree]	PT100 temperature in degrees.	0, 250	R
AV119	PTC-Resistance-[Ohm]	PTC resistance in Ohm.	0, 5000	R
AV120	Rem-Time-To-Start-[s]	Remaining time to start in seconds.	0, 3600	R
AV121	Operating-Temperature-Range-[percent]	Thyristor temperature in percent.	0, 100	R
AV122	Heat-Sink-Temperature-Range-[degree]	Heat sink temperature in degrees.	0, 150	R
AV123	Analog-Out-Command-[percent]	Controls Analog output.	0...100	W
AV124	1AO0-Analog-Out-Command-[percent]	Controls 1AO0 External I/O Analog output.	0...100	W

STATUS	SECURITY LEVEL	DOCUMENT ID.	REV.	LANG.	PAGE
Approved	Public	1SFC132381M0201	C	en	23/27

Object ID	Default Object Name	Description ⁽⁵⁾	Min / Max Present Value ⁽⁵⁾	Present Value Access Type
AV125	Active-Fault	The most recent fault currently active. 0 = No active fault 1 = High current 2 = Phase loss 3 = Heat sink overtemperature 4 = Bad network quality 5 = Shunt fault 6 = Low supply voltage 7 = Thyristor overload 8 = Short circuit thyristor 9 = Open circuit thyristor 10 = Unspecified fault 11 = Invalid ID 12 = Faulty connection 13 = Faulty usage 14 = Electronics failure 15 = Other	0...14	R
AV126	Active-Warning	The most recent warning currently active. 0 = No active warning 1 = Current imbalance 2 = Current underload 3 = Fans fault warning 4 = Electronic overload 5 = Locked rotor 6 = Over voltage 7 = Under voltage 8 = Power factor underload 9 = THD(U) 10 = Thyristor overload 11 = Voltage imbalance 12 = Short circuit 13 = EOL time-to-trip 14 = Phase loss 15 = Number of starts limit 16 = Motor run time limit 17 = Parameter storage warning 18 = Other	0...17	R

STATUS	SECURITY LEVEL	DOCUMENT ID.	REV.	LANG.	PAGE
Approved	Public	1SFC132381M0201	C	en	24/27

Object ID	Default Object Name	Description ⁽⁵⁾	Min / Max Present Value ⁽⁵⁾	Present Value Access Type
AV127	Active-Protection	The most recent protection currently active. 0 = No active protection 1 = Electronic overload 2 = Locked rotor 3 = Phase reversal 4 = Current imbalance 5 = Current underload 6 = User defined protection 7 = Ground fault 8 = Over voltage 9 = Under voltage 10 = Voltage imbalance 11 = PT100 protection 12 = PTC protection 13 = Power factor underload 14 = Too long current limit 15 = Bypass open fault 16 = Fieldbus comm. failure 17 = 24V output 18 = HMI failure 19 = Extension IO failure 20 = Max number of starts 21 = Auto-restart timeout 22 = Too long start time 23 = Frequency range 24 = IO Controller in Stop mode 25 = Other	0...24	R
AV128	Motor-Connection	0 = Auto, 1 = In Line, 2 = Inside delta UI, 3 = Inside delta IU, 4 = Two phase (L1 shorted), 5 = Two phase (L2 shorted), 6 = Two phase (L3 shorted), 7 = Unknown	0...7	R
AV129	Phase-Sequence	0 = L1 -> L2 -> L3, 1 = L1 -> L3 -> L2, 2 = Unknown	0...2	R
AV130	Kilowatt-Hour-This-Hour-[kWh]	Current hour energy consumption in kWh.	0, 3.40282347e38	R

STATUS	SECURITY LEVEL	DOCUMENT ID.	REV.	LANG.	PAGE
Approved	Public	1SFC132381M0201	C	en	25/27

Object ID	Default Object Name	Description ⁽⁵⁾	Min / Max Present Value ⁽⁵⁾	Present Value Access Type
AV131	Kilowatt-Hour-Last-Hour-[kWh]	Last hour energy consumption in kWh.	0, 3.40282347e38	R
AV132	Kilowatt-Hour-This-Day-[kWh]	Current day energy consumption in kWh.	0, 3.40282347e38	R
AV133	Kilowatt-Hour-Last-Day-[kWh]	Last day energy consumption in kWh.	0, 3.40282347e38	R
AV134	Stand-Still-Brake-Strength-[percent]	Set the stand still brake strength in percent.	10, 100	W

Table 5. Analog value objects

⁽⁵⁾ Property not supported



Information

For Present Value Access Types

R = Read-only

W = Writable

STATUS	SECURITY LEVEL	DOCUMENT ID.	REV.	LANG.	PAGE
Approved	Public	1SFC132381M0201	C	en	26/27

3. Additional Information

3.1. Listing of related documents

Ref #	Document Kind, Title	Document No.
1	Cybersecurity for ABB drives technical guide	3AXD10000492137
2	PSTX – Installation and commissioning manual	1SFC132081M0201

4. Contact us

For more information, please contact your local ABB representative or visit <https://solutions.abb/softstarters>

STATUS	SECURITY LEVEL	DOCUMENT ID.	REV.	LANG.	PAGE
Approved	Public	1SFC132381M0201	C	en	27/27