

# SACE Tmax XT

- AUX-C - Contatti ausiliari cablati 400V XT5 (2Q)
- AUX-C - Wired auxiliary contacts 400V XT5 (2Q)
- AUX-C - Hilfskontakte verdrahtet, 400V XT5 (2Q)
- AUX-C - Contacts auxiliaires câblés 400V XT5 (2Q)
- AUX-C - Contactos auxiliares cableados 400V XT5 (2Q)
- AUX-C - 带导线辅助触点 400V XT5 (2Q)

XT5

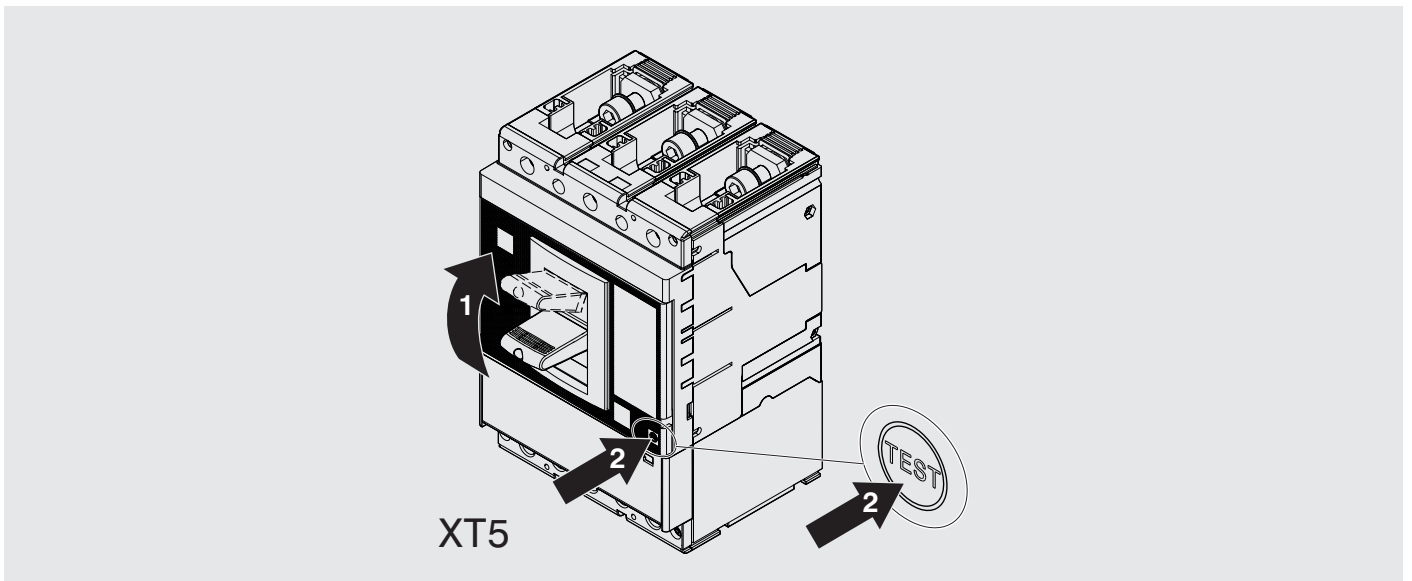

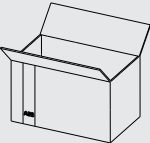

**A**

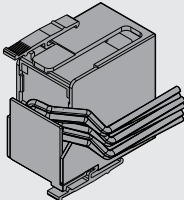

**B**

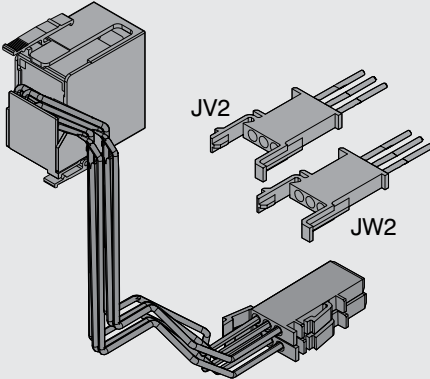

**C**

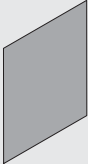

F - P	1	/	1
W	/	1	1

1

IEC60947-5-1 

	Voltage	max Current
IEC	250Vac	12A
	400Vac	3A

IEC60947-5-1 

	Voltage	max Current
IEC	220Vdc	0.2A
	110Vdc	0.4A
	24Vdc	16A



	Voltage	max Current
UL	250Vac	12A

2

F/P

	Q/5	Q/6
CAVI CABLES KABEL CÂBLES CABLES 导线	71-72-74	81-82-84

	XT5	
	Thermal-magnetic and Ekip Dip trip unit	Ekip Touch and Hi-Touch trip unit
2Q	OK	OK

W

	Q/5	Q/6
CAVI CABLES KABEL CÂBLES CABLES 导线	71-72-74	81-82-84
CONNETTORE CONNECTOR STECKVORRICHTUNG CONNECTEUR CONNECTOR 连接器	JV2	JW2

	XT5	
	Thermal-magnetic and Ekip Dip trip unit	Ekip Touch and Hi-Touch trip unit
2Q	OK	OK

3

F 4

F

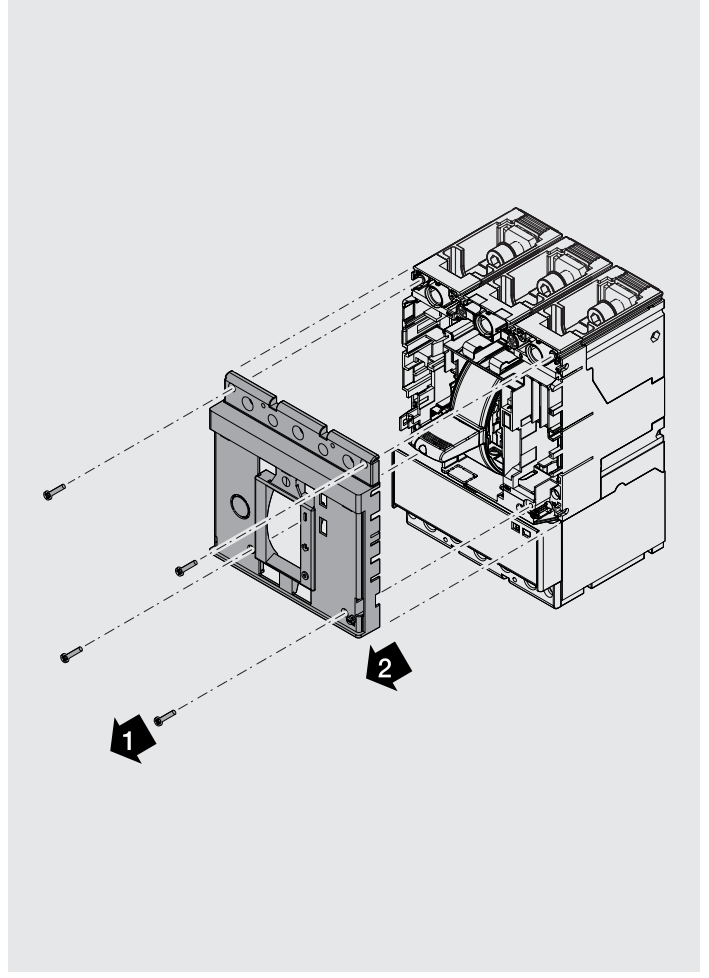
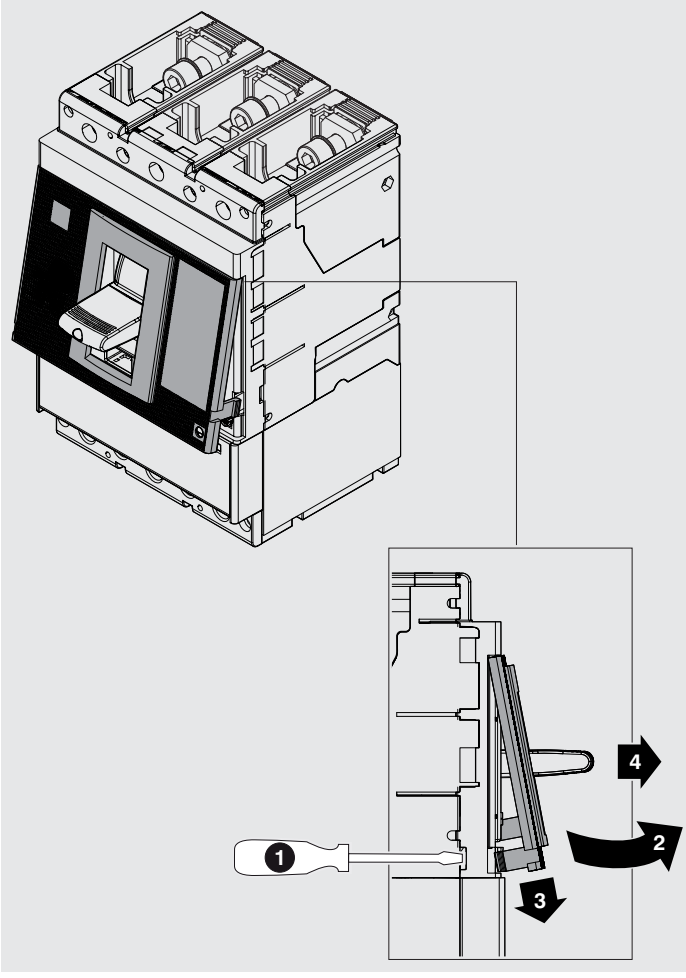

5

F

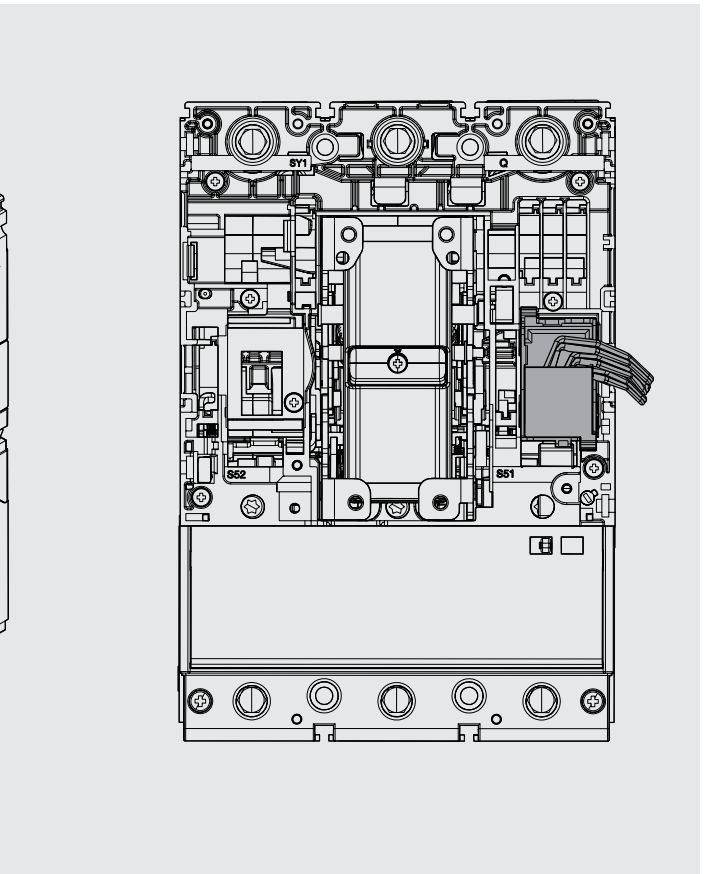
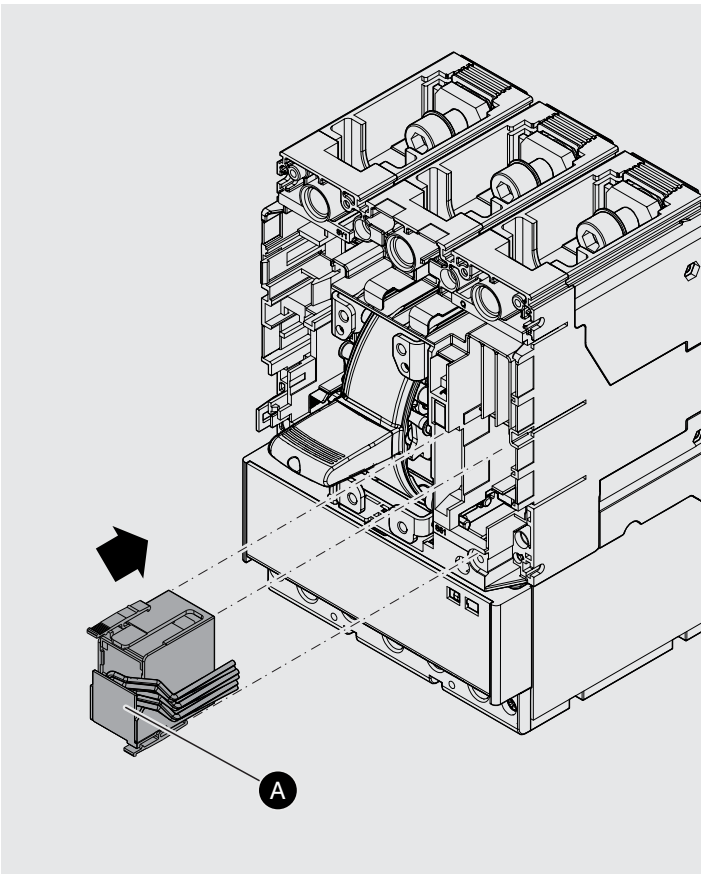

6

F 7

F

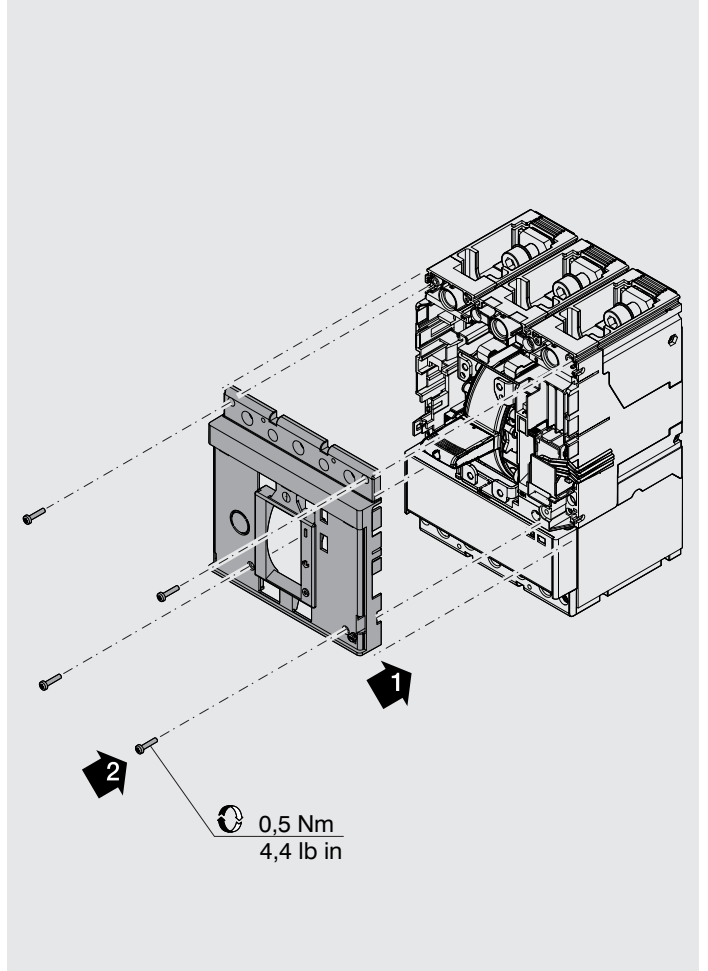
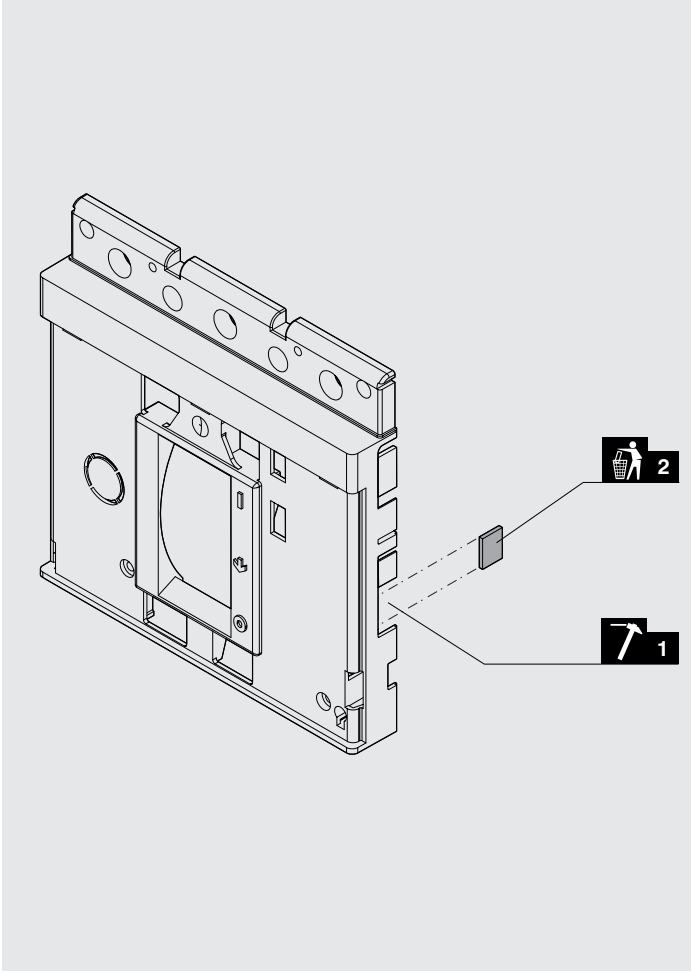

8

F

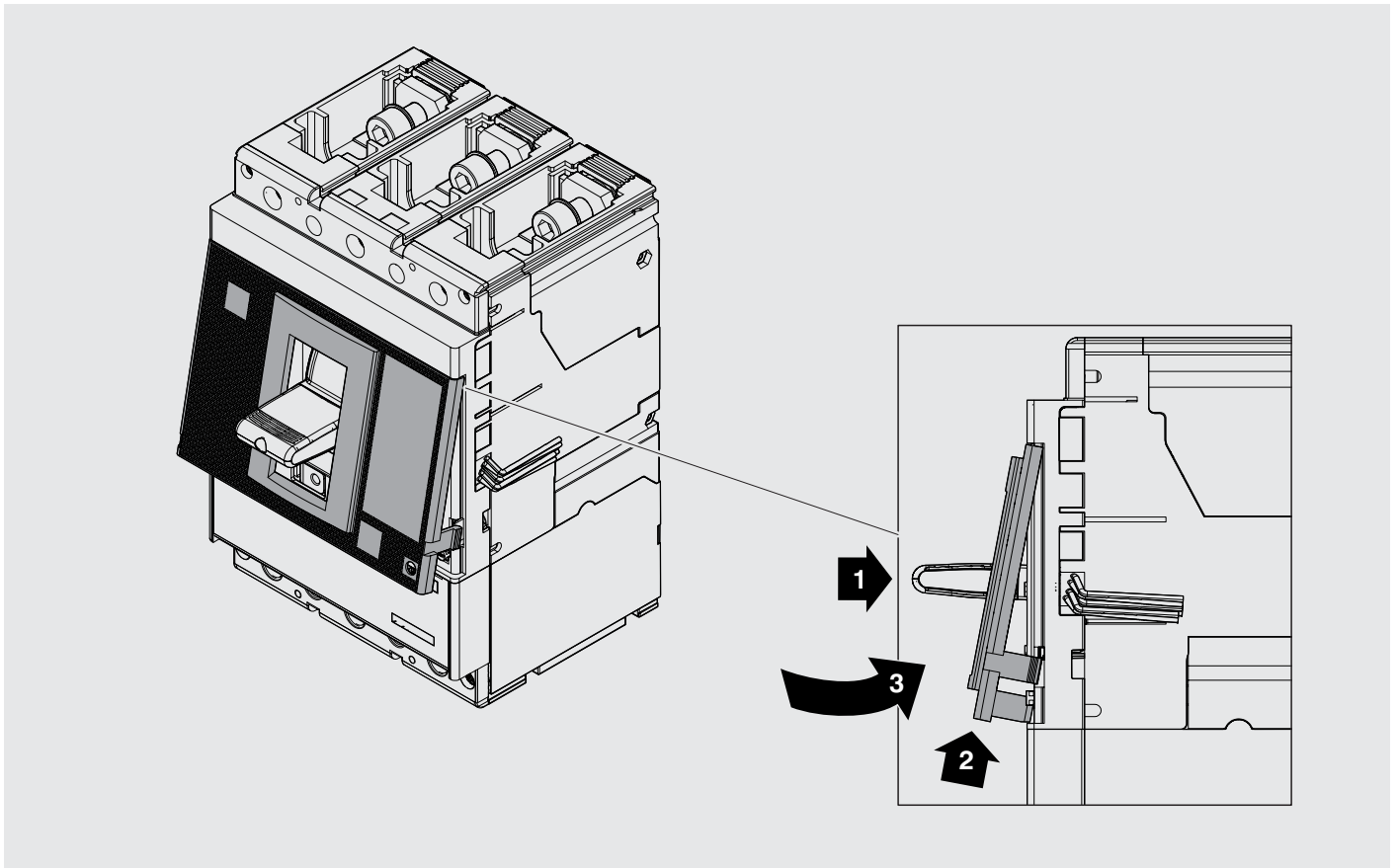

9

W 10

W

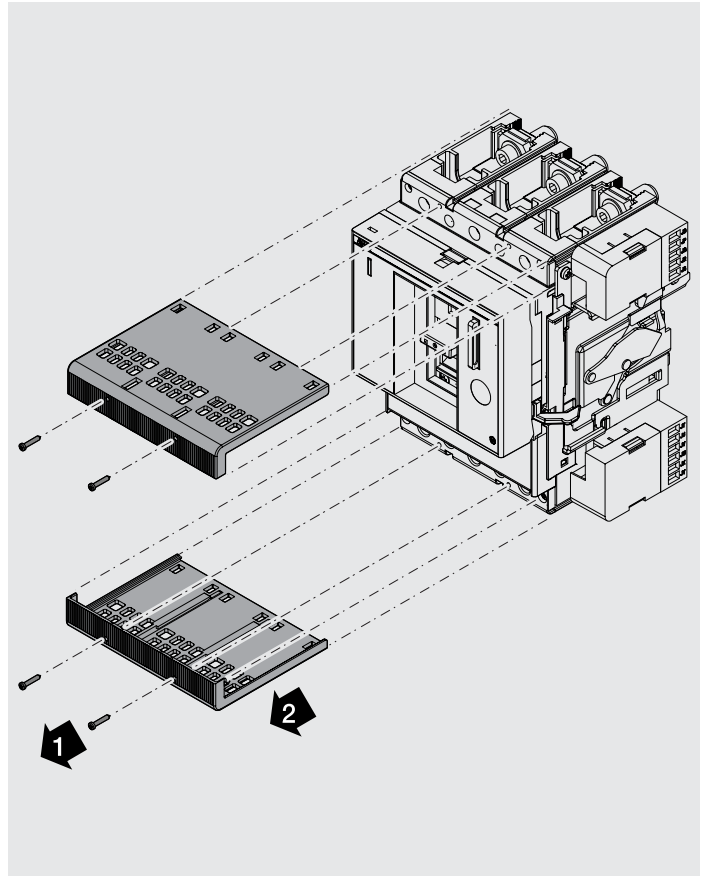
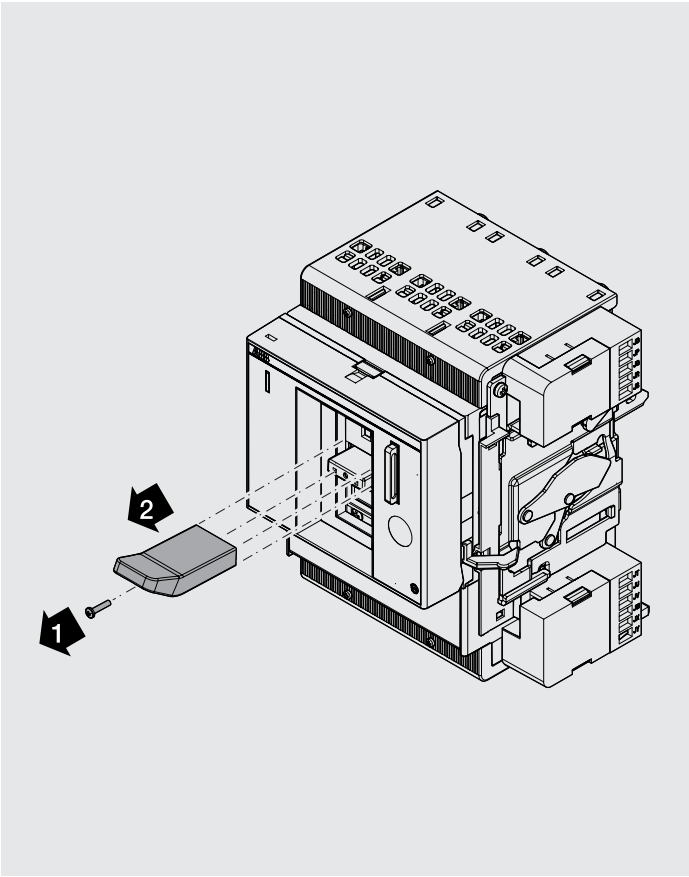

11

W 12

W

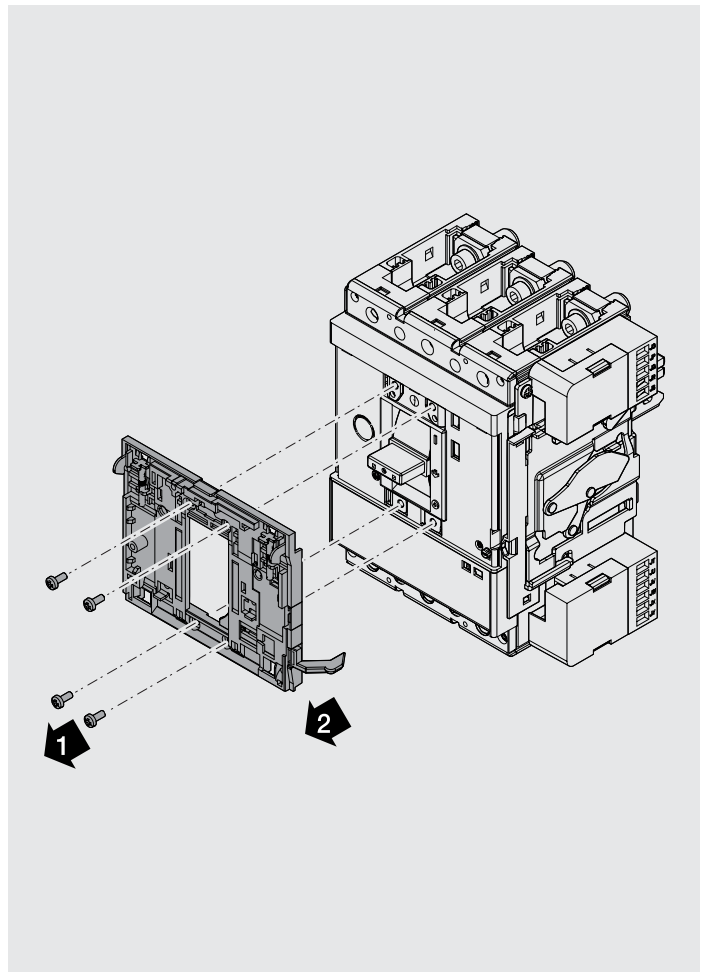
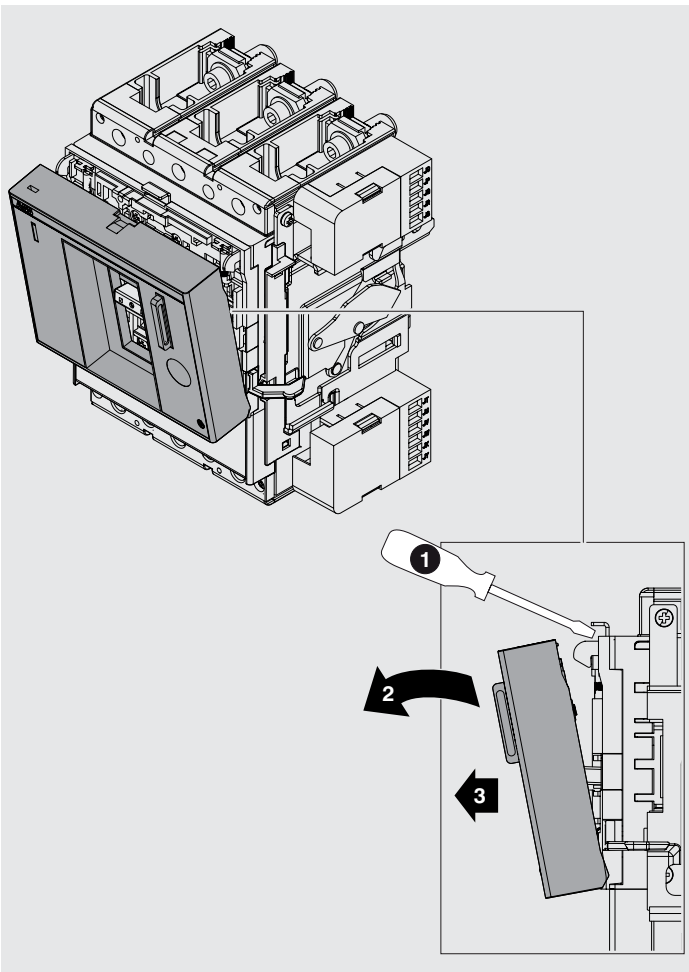

13

W 14

W

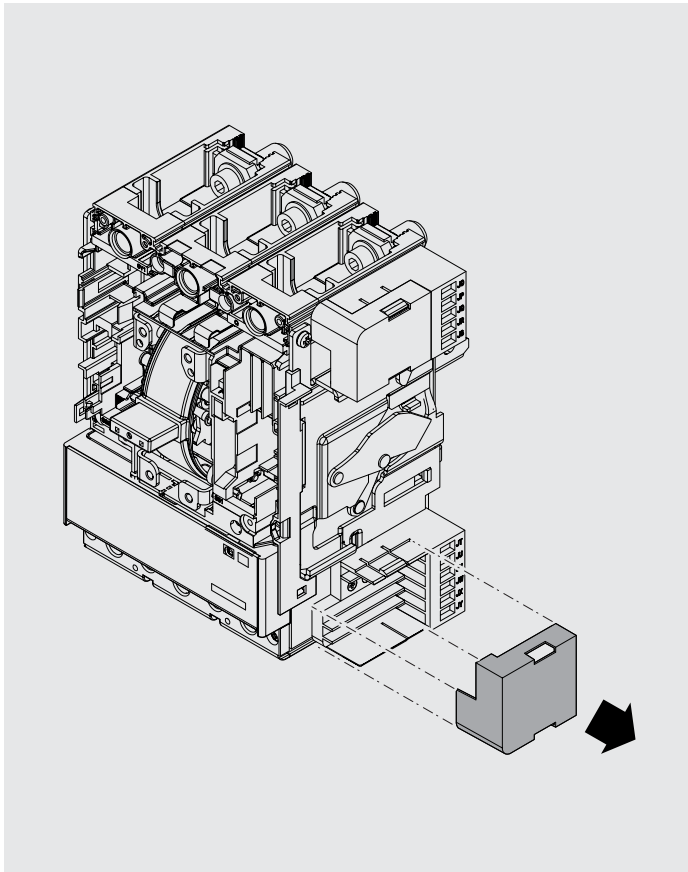
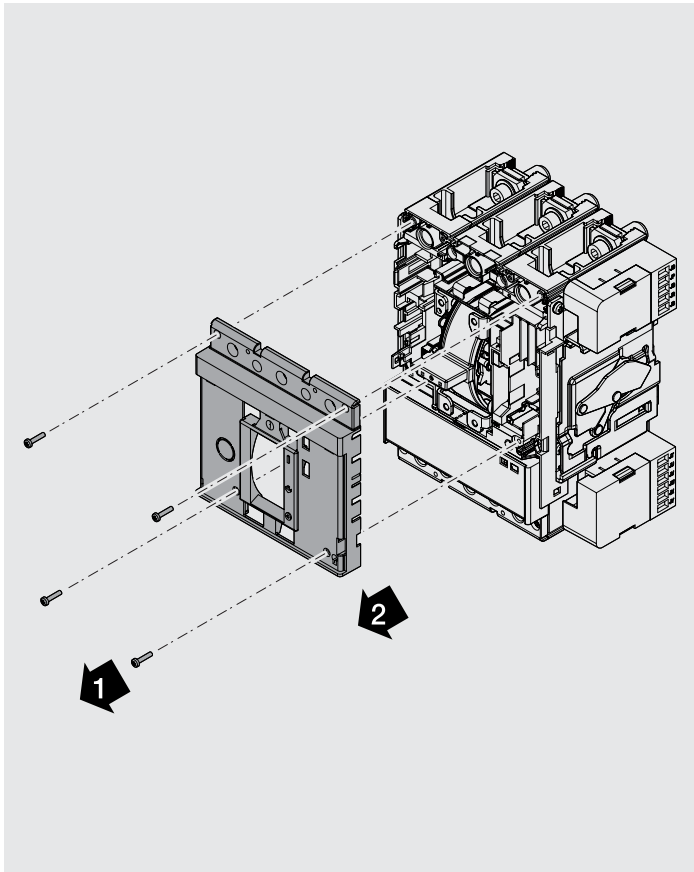

15

W

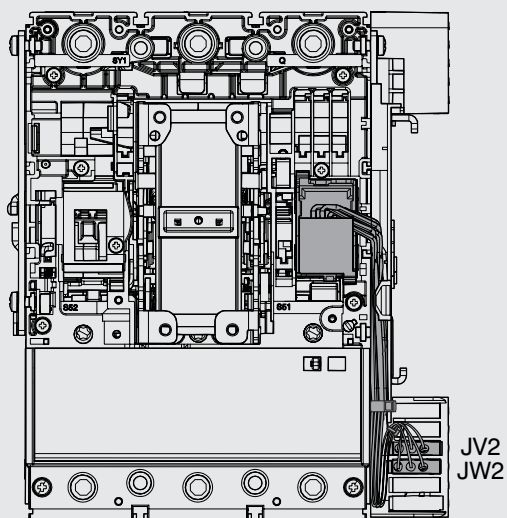
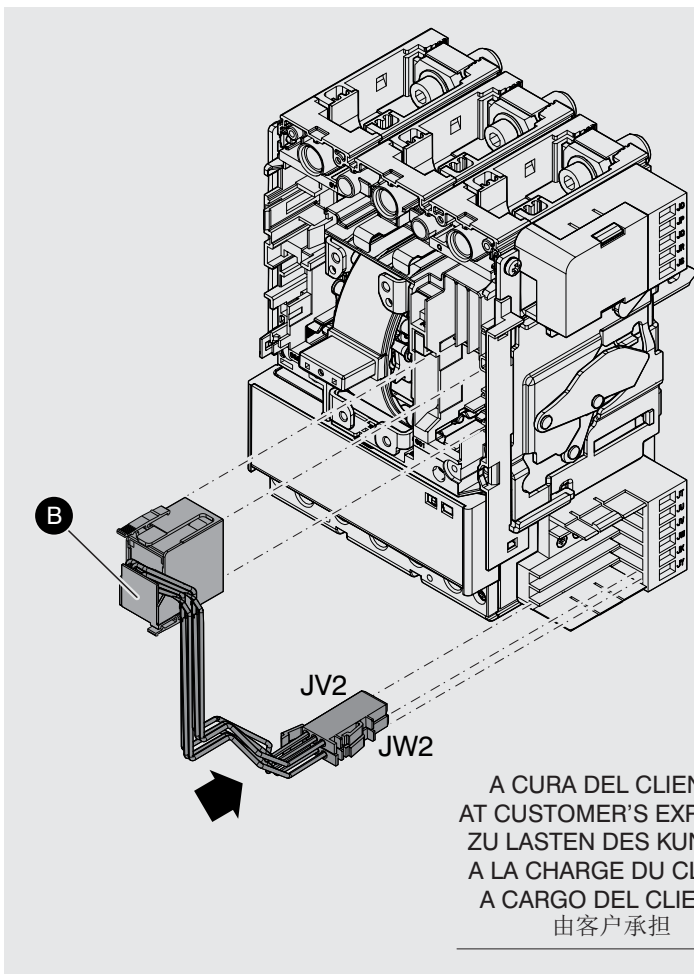

A CURA DEL CLIENTE  
 AT CUSTOMER'S EXPENSE  
 ZU LASTEN DES KUNDEN  
 A LA CHARGE DU CLIENT  
 A CARGO DEL CLIENT  
 由客户承担

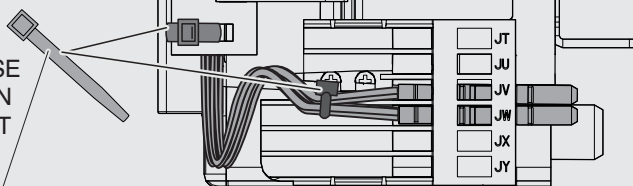

16

W 17

W

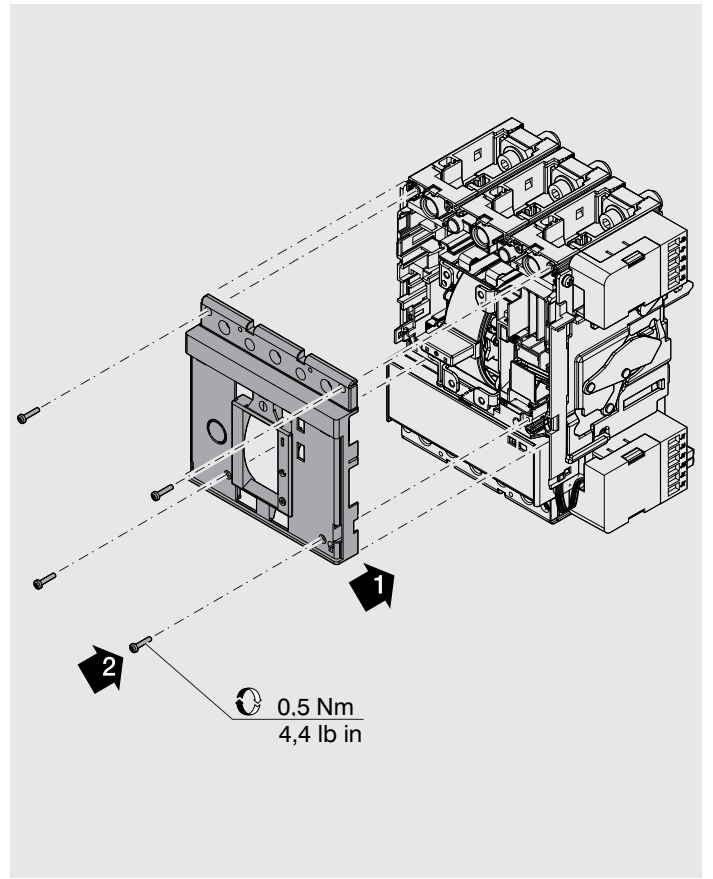
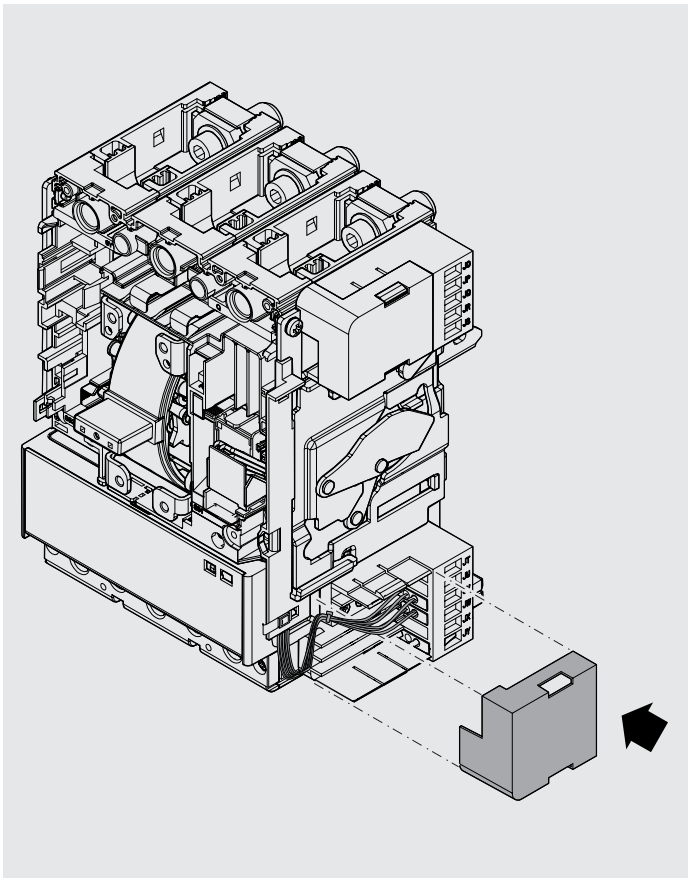

18

W

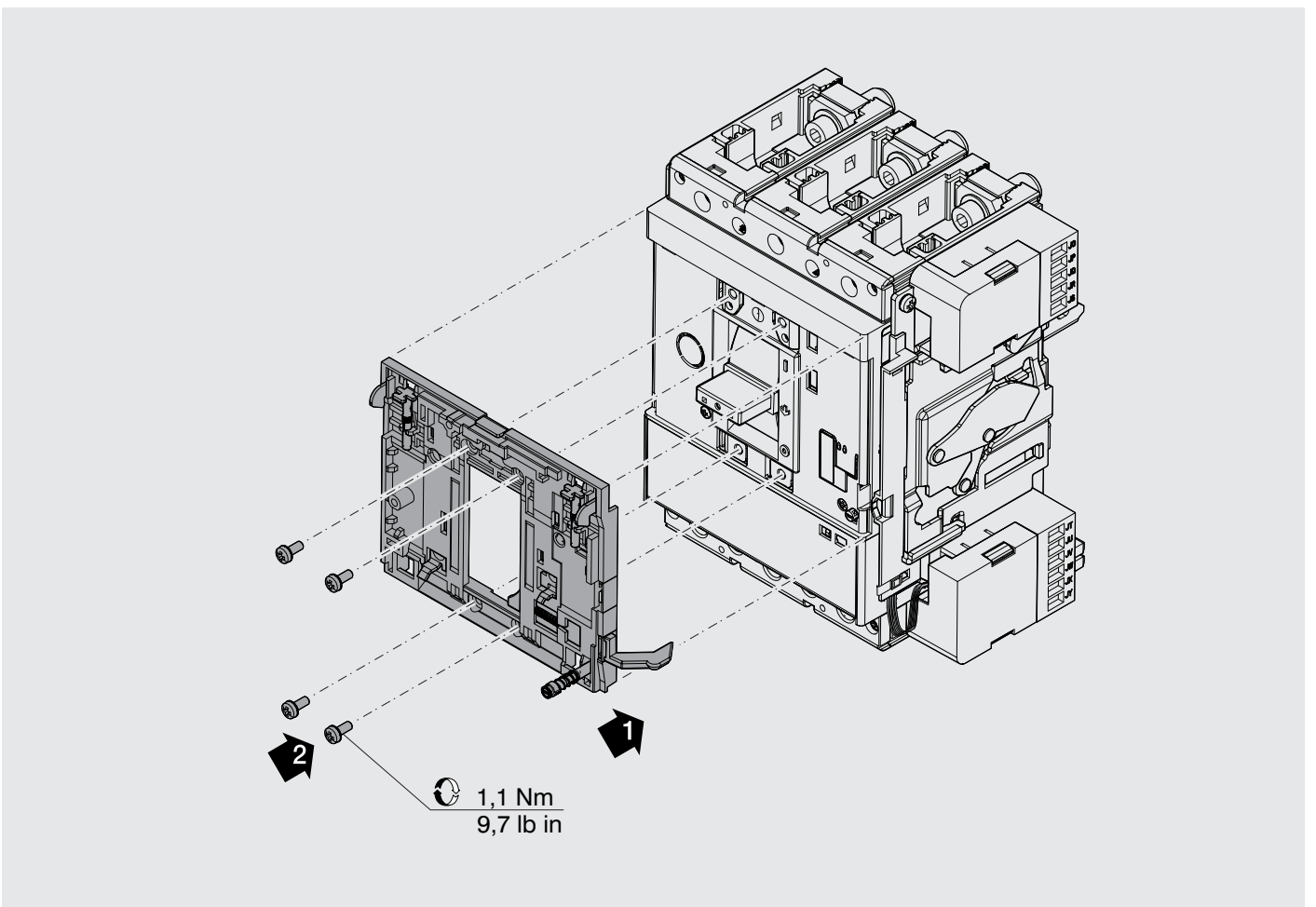

19

W 20

W

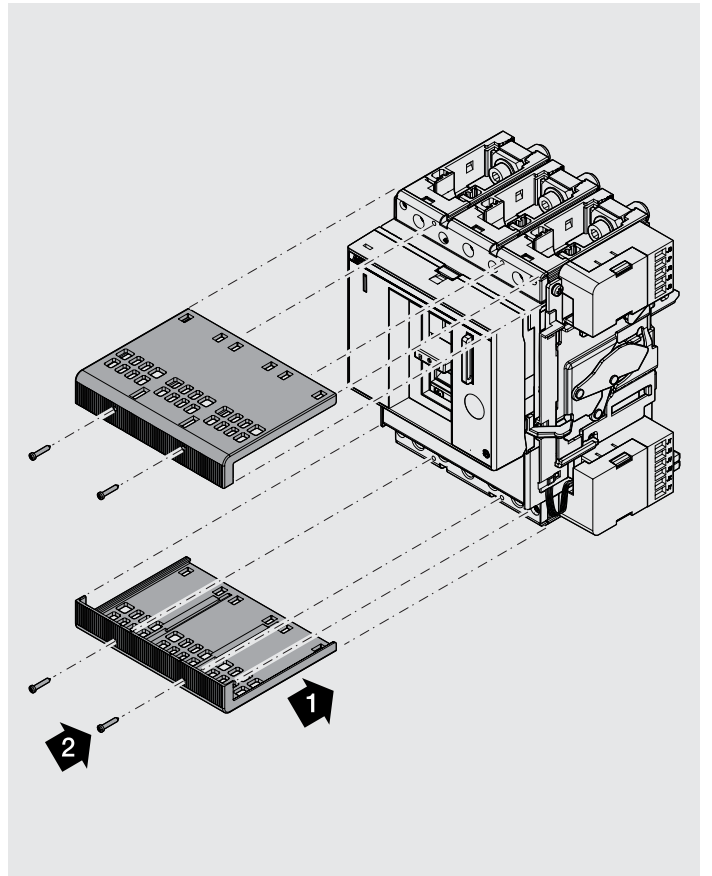
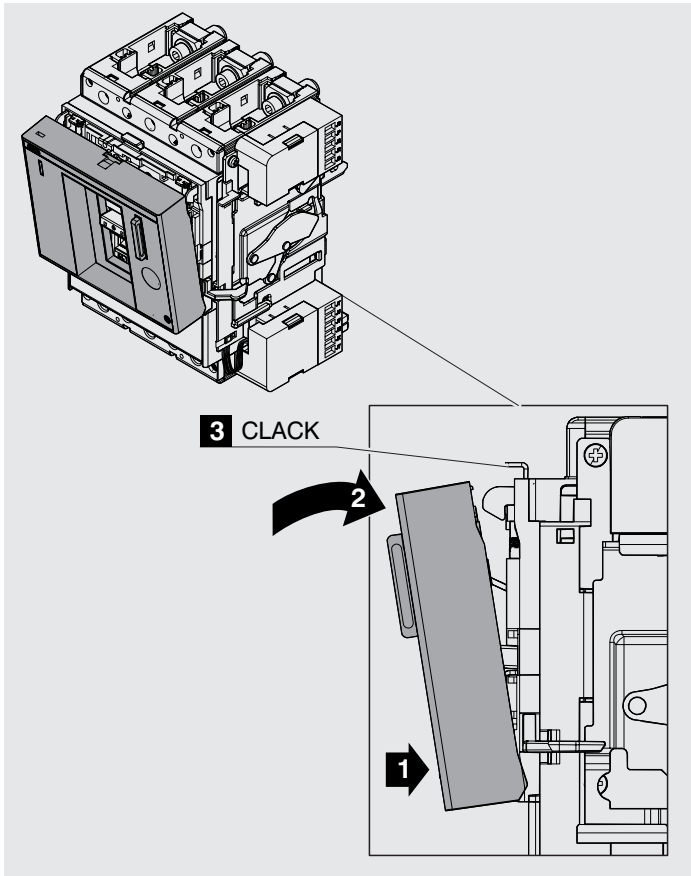

21

W 22

W

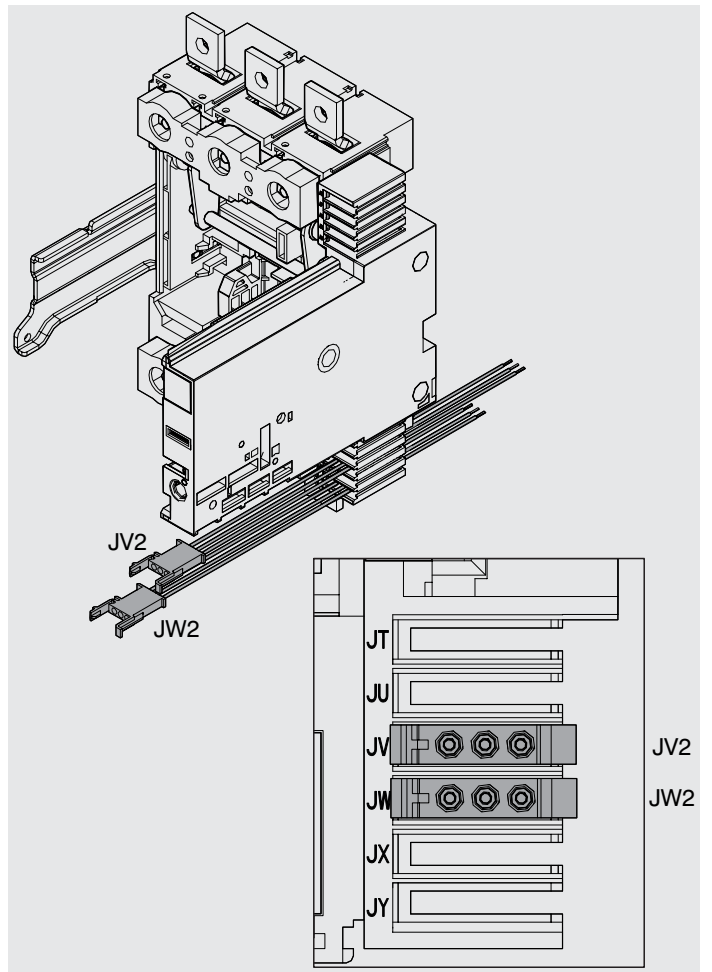
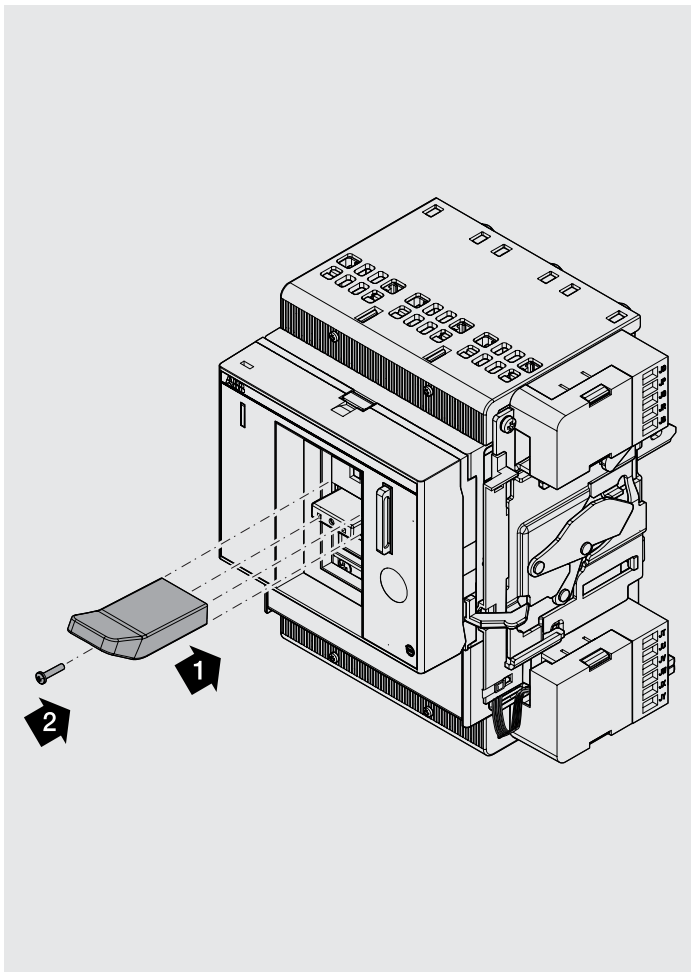

Example with XT5 F

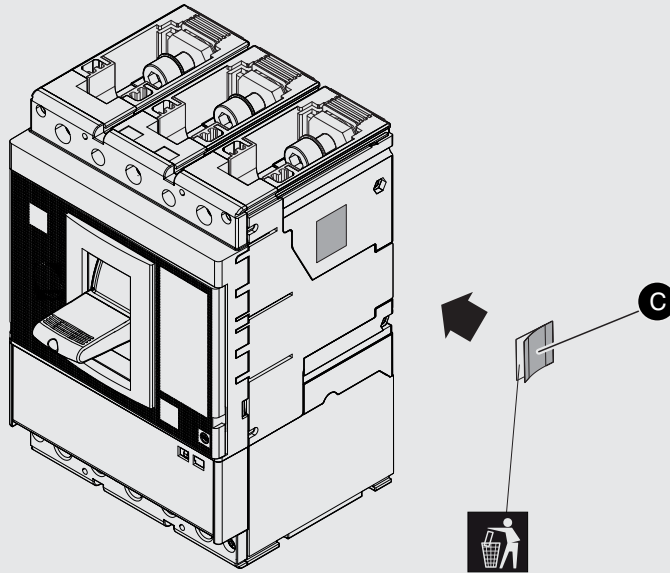

2 CONTATTI SEGNALAZIONE  
 INTERRUOTORE APERTO -  
 CHIUSO (PER TENSIONI FINO A  
 400V)

OPEN - CLOSED C. BREAKER 2  
 SIGNALLING CONTACTS (FOR  
 VOLTAGE UP TO 400V)

\* D)

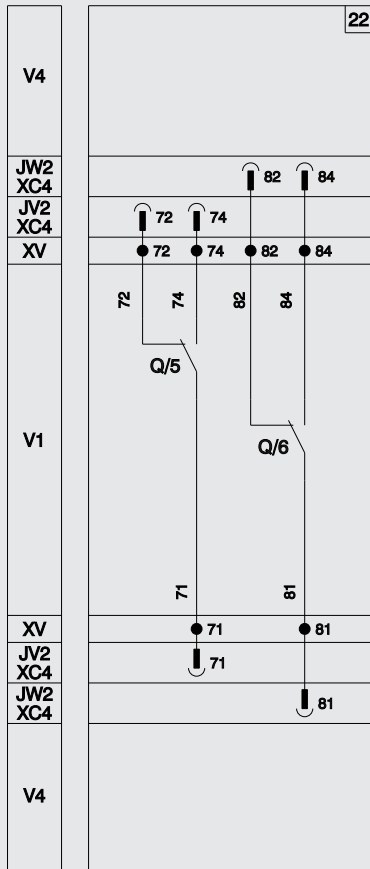

\*Per ulteriori informazioni vedere:  
 \*For further details consult:  
 \*Für weitere Informationen siehe:  
 \*Pour plus d'informations voir:  
 \*Para más información véase:  
 \*有关更多信息请参考:

1SDM000005A1001