

GA-2

Grease Separator Alarm Device with two sensors

Installation and Operating Instructions



TABLE OF CONTENTS

1	GENERAL.....	3
2	INSTALLATION	4
2.1	GA-2 Grease Alarm control unit.....	4
2.2	Installation of sensors	5
2.3	Installation accessories	5
3	OPERATION.....	6
3.1	Mode of operation	6
4	TROUBLE-SHOOTING	8
5	REPAIR AND SERVICE	9
6	SAFETY INSTRUCTIONS.....	9
7	TECHNICAL DATA.....	10

SYMBOLS



Warning / Attention



Device is protected by double or reinforced insulation

1 GENERAL

GA-2 Grease Alarm is an alarm device for monitoring the thickness of the grease layer accumulating in the grease separator and blocking of the separator. The delivery consists of GA-2 Grease Alarm control unit, grease alarm sensor GA-SG1, blockage sensor GA-HLL1, and cable joint.

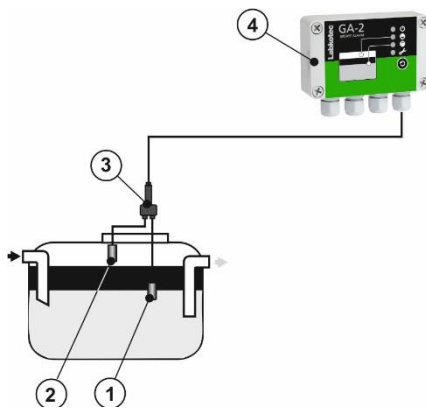

System components:

1. GA-SG1 sensor (grease alarm)
2. GA-HLL1 sensor (blockage)
3. Cable joint
4. GA-2 control unit

Figure 1. Grease separator alarm system with GA-2 Grease Alarm

The GA-SG1 grease alarm sensor is installed into the grease storage chamber and supervises thickness of grease layer.

The blockage sensor GA-HLL1 is installed above the grease storage chamber and supervises the total liquid level of the separator and gives an alarm from possible blockage.

The LED indicators, push button and interfaces of the device are described in figure 2.

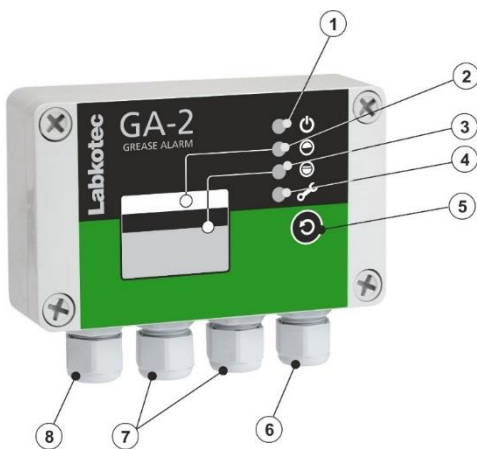

GA-2 USER INTERFACE FEATURES

1. LED indicator for mains
2. LED indicator for blockage alarm sensor
3. LED indicator for grease alarm sensor
4. LED indicator for fault
5. Alarm Reset/Test push button
6. Connectors for grease alarm and blockage sensors
7. Relay outputs for monitoring and control purposes.
8. Supply voltage

Figure 2. GA-2 Grease Alarm –features

2 INSTALLATION

2.1 GA-2 Grease Alarm control unit

The GA-2 Grease Alarm control unit can be wall-mounted. The mounting holes are located in the base plate of the enclosure, beneath the mounting holes of the front cover.

The connectors of the external conductors are isolated by separating plates. The plates must not be removed.

The cover of the enclosure must be tightened so, that the edges touch the base frame. Only then does the push button function properly and the enclosure is tight.

Before installation, please read the safety instructions in chapter 6!

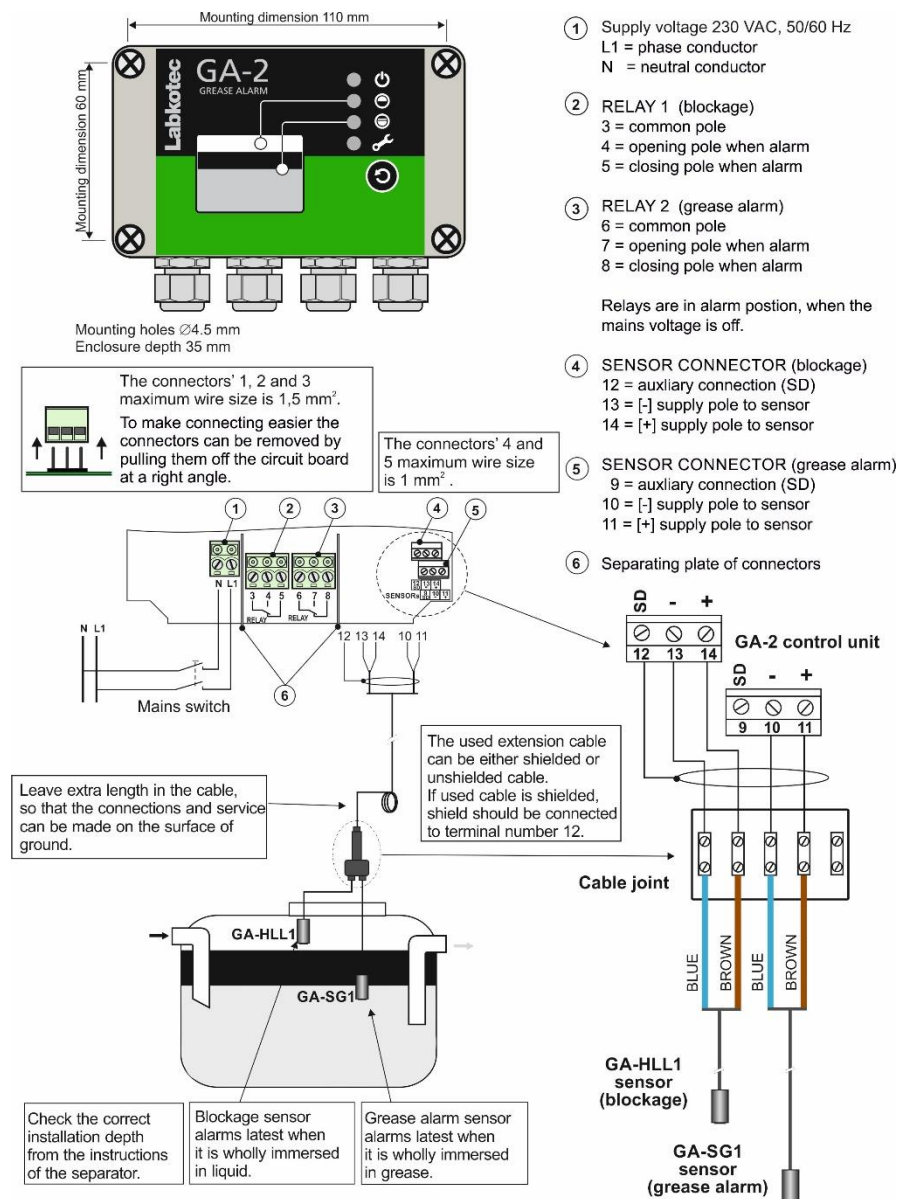

Figure 3. Installation of GA-2 Grease Alarm device.

2.2 Installation of sensors

The sensor installation should be done as described in figure 3.

Grease alarm sensor gives an alarm latest when it is wholly immersed in grease.

Blockage sensor gives an alarm latest when it is wholly immersed in liquid.

Please check the correct installation depth also from the instructions of the grease separator.

2.3 Installation accessories

The delivery includes a cable joint (figure 4), fixing accessories (figure 5) for installation of the control unit and the sensor. In figure 6 is an installation example of cable with suspension hook.

Connections of the sensor cable inside the cable joint are explained in figure 3. If shielded cable is used cable shields and possible excess wires need to be connected to the same point in galvanic contact.

IP rating of the cable joint is IP68. Make sure, that the cable joint is closed properly.



Figure 4. Cable joint



Figure 5. Fixing accessories



Figure 6. Cable installation example

3 OPERATION

The operation of the device should always be checked after the installation. The operation should also be checked always when emptying the separator or at least once every six months.

<i>Functionality test</i>	<p>Blockage alarm</p> <ol style="list-style-type: none"> 1. Lift the sensor up in the air. The device should be in normal mode (see chapter 3.1). 2. Immerse the sensor into water. Blockage alarm should occur (see chapter 3.1). 3. Lift the sensor up in the air again. The alarm should go off after 10 sec delay.
---------------------------	--

<i>Functionality test</i>	<p>Grease alarm</p> <ol style="list-style-type: none"> 1. Immerse the sensor into water. The device should be in normal mode (see chapter 3.1). 2. Lift the sensor up in the air or immerse into grease. Grease alarm should occur. (see chapter 3.1). 3. Immerse the sensor back into water. Alarm should go off after 10 sec delay.
---------------------------	---

Clean up the sensors before placing them back into the separator.

A more detailed description of the operation is provided in chapter 3.1. If the operation is not as described, contact a representative of the manufacturer.

3.1 Mode of operation

<i>Normal mode – no alarms</i>	<p>Grease alarm sensor is totally in water and blockage sensor is in the air. Mains LED indicator is on. Other LED indicators are off. Relays 1 and 2 are energized.</p>
--------------------------------	--

<i>Blockage alarm</i>	<p>The level has hit the blockage sensor. (Sensor gives an alarm earliest when level is on the middle of sensor and latest when the sensor is wholly immersed in liquid.) Mains LED indicator is on. Blockage alarm LED indicator is on. Buzzer on after 10 sec delay. Relay 2 remains energized. Relay 1 de-energizes after 10 sec delay.</p>
-----------------------	--

<i>Grease alarm</i>	<p>Grease alarm sensor is in grease. (Sensor gives an alarm latest when it is wholly immersed in grease.) (Note! The same alarm takes place when grease alarm sensor is in the air) Mains LED indicator is on. Grease alarm LED indicator is on. Buzzer on after 10 sec delay. Relay 2 de-energizes after 5 sec delay.</p>
---------------------	--

After removal of an alarm, the respective alarm LED indicators and buzzer will be off and respective relay will be energized after 10 sec delay.

<i>Fault alarm</i>	<p>A broken sensor, sensor cable break or short circuit, i.e. too low or too high sensor signal current. Mains LED indicator is on. Sensor circuit Fault LED indicator is on after 10 sec delay.</p>
--------------------	--

*Buzzer is on after 10 sec delay.
The relay of the respective channel de-energizes after 10 sec delay.*

Reset of an alarm

*When pressing the Reset push button.
Buzzer will go off.
Relays will not change their status before the actual alarm or fault is off.
If the buzzer is not reset, it goes off automatically after three days.*

TEST FUNCTION

Test function provides an artificial alarm, which can be used to test the function of the GA-2 Grease Alarm and the function of other equipment, which is connected to GA-2 via its relays.



Attention! Before pressing Test button, make sure that the change of relay status does not cause hazards elsewhere!

Normal situation

*When pressing the Test push button:
Alarm and Fault LED indicators are immediately on.
Buzzer is immediately on.
Relays de-energize after 2 sec of continuous pressing.

When the Test push button is released:
LED indicators and buzzer go immediately off.
Relays energize immediately.*

Blockage or Grease alarm on

*When pressing the Test push button:
Fault LED indicators are immediately on.
The Alarm LED indicator of the alarming channel remains on and the respective relay remains de-energised.
Alarm LED indicator of the other channel is on and the relay de-energizes.
Buzzer remains on. If it has been reset earlier, it will return to be on.

When the Test push button is released:
The device returns without delay to the preceding status.*

Fault alarm on

*When pressing Test push button:
The device does not react with regards to the faulty channel.
The device reacts as described above with regards to the functional channel.*

4 TROUBLE-SHOOTING



Attention! When testing blockage sensor, grease alarm sensor must be in the same water tank or container!

Problem: No alarm when grease alarm sensor in grease or air, or the alarm will not go off

Possible reason: Sensor is dirty.

To do: 1. Clean-up the sensor and check the operation again.
Measure sensor current and voltage, if necessary as described below.

Problem: No alarm when blockage sensor in liquid, or the alarm will not go off

Possible reason: Sensor is dirty.

To do: 1. Clean-up the sensor and check the operation again.
Measure sensor current and voltage, if necessary as described below.



The following operations must be performed only by a qualified electrician!

Problem: MAINS LED indicator is off

Possible reason: Device doesn't get supply voltage.

To do: 1. Check that power separation switch is not switched off.
2. Measure the voltage between poles N and L1. It should be 230 VAC \pm 10 %.

Problem: FAULT LED indicator is on

Possible reason: Current in sensor circuit too low (cable break or out of connector) or too high (cable in short circuit). The sensor might also be broken.

To do: 1. Make sure, that the sensor cable has been connected correctly to the GA-2 control unit.
2. Measure the voltage separately between the poles 10 and 11 as well as 13 and 14. The voltages should be between 7,0 - 8,5 V. Note! The voltage alternates between the sensor connectors in 1 second intervals.
3. Measure sensor current when the sensor is in the air or in grease. The measured current should be 7,0 – 8,5 mA.
4. Measure current when the sensor is in the water. Measured current should be 2,5 – 3,5 mA

If the problems can not be solved with the above instructions, please contact Labkotec Oy's local distributor or Labkotec Oy's service.

5 REPAIR AND SERVICE

The sensors should be cleaned and the operation of the alarm device should be tested when emptying or maintaining the grease separator or at least once every six months. For cleaning, a mild detergent (e.g. washing-up liquid) and a scrubbing brush can be used.

In case of queries, please contact Labkotec Oy's service.

6 SAFETY INSTRUCTIONS



The device does not include a mains switch. A two pole mains switch (250 VAC 1 A), which isolates both lines (L1, N) must be installed in the main power supply lines in the vicinity of the unit. This switch facilitates maintenance and service operations and it has to be marked to identify the unit. Fuse maximum 10 A.



If opening of housing's cover is needed, only an authorized electrician is allowed to install or to maintain the device.



If the device is used against the manufacturer's instructions, the protection provided by the device may be damaged.



The device is not allowed to install in hazardous areas.

7 TECHNICAL DATA

GA-2 control unit	
Dimensions	125 mm x 75 mm x 35 mm (l x h x d)
Weight	250 g Package 1,2 kg (control unit + 2 sensors + cable joint)
Enclosure	IP 65, material polykarbonate Cable glands adjustment range is 6 – 10mm
Operation temperature	-30 °C...+50 °C
Supply voltage	230 VAC ± 10 %, 50/60 Hz The device is not equipped with a mains switch. Fuse maximum 10 A.
Power consumption	5 VA
Relay output	2 pcs potential-free relay outputs 250 V, 5 A Operational delay 10 sec. Relay de-energize at trigger point.
Electrical safety	IEC/EN 61010-1, Class II  , CAT II
EMC	Emission IEC/EN 61000-6-3 Immunity IEC/EN 61000-6-1
Manufacturing year: Please see the serial number on the type plate	xxx x xxxxx xx YY x where YY = manufacturing year (e.g. 19 = 2019)

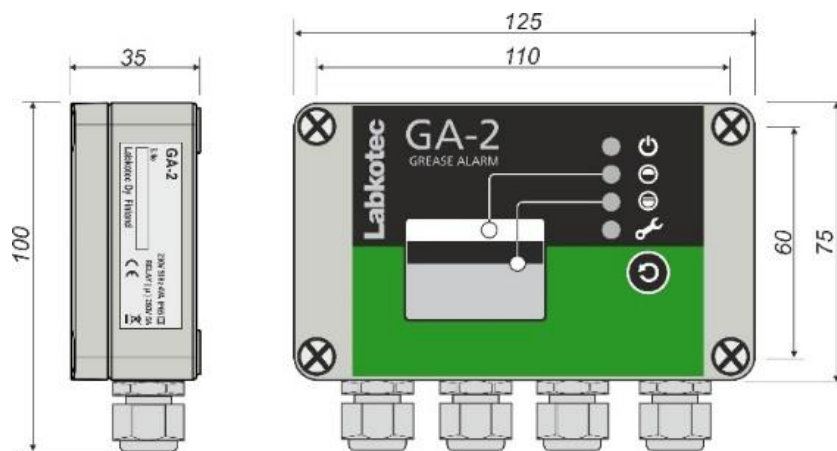

Figure 7. GA-2 control unit

GA-SG1 and GA-HLL1 sensors	
Principle of operation	Capacitive
Material	POM, chlorinated polyethylene rubber (CM), AISI 316
Weight	350 g (sensor + fixed cable)
IP-classification	IP68
Operation temperature	0 °C...+90 °C
Cable	Fixed cable 2 x 0,75 mm ² . Standard length 5 m, other lengths optional. The max. length of the fixed cable is 15 m, can be extended. Maximum cable loop resistance is 75Ω.
EMC	Emission Immunity
	IEC/EN 61000-6-3 IEC/EN 61000-6-1
Manufacturing year: Please see the serial number from the bottom of sensor	GAxxxxxYY / GAHxxxxxYY where YY = manufacturing year (e.g. 19 = 2019)

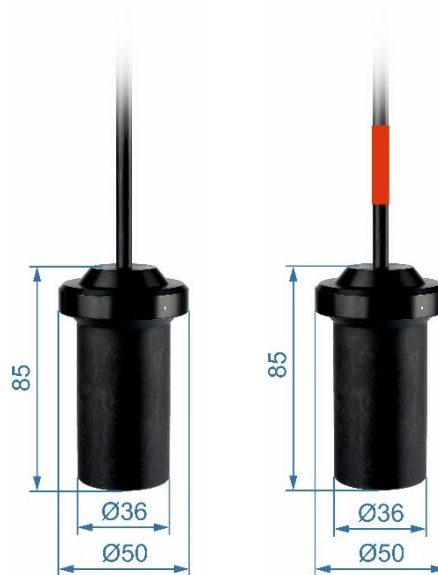

Figure 8. Sensors GA-SG1 and GA-HLL1

EU DECLARATION OF CONFORMITY

We hereby declare that the product named below has been designed to comply with the relevant requirements of the referenced directives and standards.

Product	Measuring and control units and sensors GA-1 Grease Alarm Control Unit GA-2 Grease Alarm Control Unit GA-SG1 Sensor GA-HLL1 Sensor
Manufacturer	Labkotec Oy Myllyhaantie 6 FI-33960 Pirkkala Finland
Directives	The product is in accordance with the following EU Directives: 2014/30/EU Electromagnetic Compatibility Directive (EMC) 2014/35/EU Low Voltage Directive (LVD) 2011/65/EU Restriction of Hazardous Substances Directive (RoHS)
Standards	The following standards were applied: EMC: EN 61000-6-1:2007 EN 61000-6-3:2007/A1:2011/AC:2012 EN 61000-3-2:2014 EN 61000-3-3:2013 LVD: EN 61010-1:2010 RoHS: EN 50581:2012

The product is CE-marked since 2013.

Signature This declaration of conformity is issued under the sole responsibility of the manufacturer. Signed for and on behalf of Labkotec Oy.

Pirkkala 24.6.2019



Janne Uusinoka, CEO
Labkotec Oy