

Lite Panel User Manual

User manual

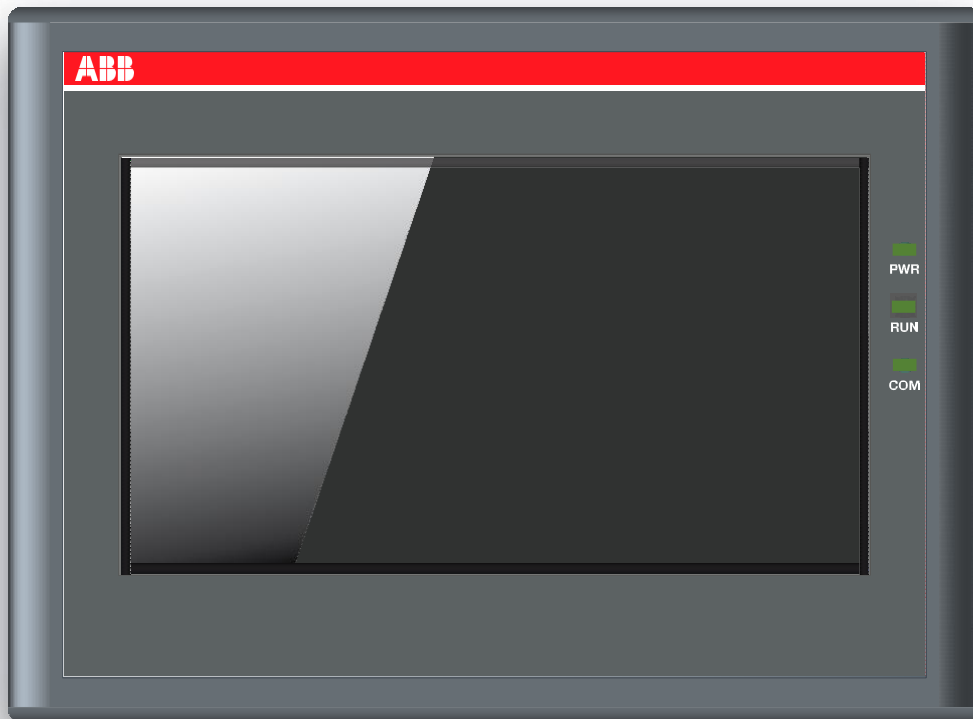

1. CONTENTS

| | |
|--|-----------|
| Safety..... | 2 |
| Cyber security legal disclaimer..... | 3 |
| 1.INTRODUCTION..... | 4 |
| 1.1 Scope | 4 |
| 1.2 Application | 5 |
| 1.3 Supported devices | 6 |
| 1.4 Software | 7 |
| 2. HARDWARE | 8 |
| 2.1 Hardware installation..... | 8 |
| 2.1.1 Hardware installation condition..... | 8 |
| 2.1.2 Hardware installation guide..... | 9 |
| 2.1.3 Power connection..... | 10 |
| 2.1.4 CE Requirement..... | 12 |
| 2.1.5 Installation diagram..... | 13 |
| 2.2 Hardware introduction..... | 14 |
| 2.2.1 Hardware structure..... | 14 |
| 2.2.2 Hardware parameter..... | 16 |
| 3.Lite Panel ICON DESCRIPTION..... | 17 |
| 4.Lite Panel FUNCTIONS..... | 19 |
| 4.1 Lite Panel user management..... | 19 |
| 4.1.1 User privilege..... | 19 |
| 4.1.2 User login..... | 20 |
| 4.1.3 Factory reset for password..... | 21 |
| 4.2 Lite Panel home page introduction..... | 22 |
| 4.3 Lite Panel system setting..... | 23 |
| 4.4 Lite Panel device management..... | 27 |
| 4.4.1 Scan devices via Modbus TCP..... | 27 |
| 4.4.2 Scan devices via Modbus RTU..... | 28 |
| 4.4.3 Delete device..... | 29 |
| 4.5 Device monitor and remote control..... | 30 |
| 4.5.1 Device monitor pages..... | 30 |
| 4.5.2 Device pages matrix..... | 33 |
| 4.5.3 Device remote control..... | 34 |
| 4.5.4 Real time alarm..... | 35 |
| 5.FIRMWARE UPGRADE..... | 36 |
| 6.TROUBLESHOOTING..... | 37 |
| 7.ANNEX..... | 38 |



WARNING



HAZARDOUS VOLTAGE CAN CAUSE SHOCKS, BURNS OR DEATH.

Do not use this product in any way before having read this instruction manual

PLEASE READ THIS DOCUMENT CAREFULLY BEFORE INSTALLING OR USING THIS SOFTWARE WITH CIRCUIT BREAKER AND RELATED DEVICES.

- Store these instructions in conjunction with any other instructions, drawings, and descriptive documents. Keep this document available for use.
- Follow the safety procedures specified by your Company.
- Do not remove covers, open doors, or work on the equipment connected to the device, if you have not cut off the power to the switchboard, and before all the circuits are powered down.



WARNING!

- Detailed descriptions for the standard installation, use and maintenance procedures and principles for operating in safety are not included: it is important to note that this document contains safety and caution indications against certain methods (of installation, use and maintenance) that could harm persons, damage devices or make them less safe.
- These warnings and alarms do not encompass all conceivable installation, use and maintenance methods recommended or not recommended by ABB that could be applied and possible consequences and complications of each conceivable method. Neither will ABB investigate all these methods.
- Anybody who used maintenance procedures or devices, recommended by ABB or not has to check thoroughly that neither personal safety or safety devices are placed in danger by the installation method, use, maintenance or by the instruments used; for further information, explanations or specific problems contact the nearest ABB.
- This manual has been written only for qualified persons and is not to be intended as substitute for a suitable course or experience with the safety procedures for this device.
- The purchaser, the installer or the final customer and person responsible for ensuring that safety warnings and notices are displayed and also that all the access points and operating devices are safely locked when the switchgear is left unattended.
- All the information contained in this document is based on the latest information available at the moment of publication. We reserve the right to modify the document at any moment without prior notice.
- This software is ABB property and is guaranteed only for use with ABB devices. Duplication and distribution, not previously authorized by ABB, are strictly forbidden. Any action of disassembly, modification or handling of this software is forbidden.

Cyber security legal disclaimer

Lite Panel is designed to be connected and to communicate information and data via a network interface, which should be connected to a secure network. It is the sole responsibility of the customer to provide and continuously ensure a secure connection between the product and the customer network or any other network. The customer is required to establish and maintain any appropriate measures (including but not limited to the installation of firewalls, application of authentication measures, encryption of data, installation of anti-virus programs, etc.) to protect the product, the network, its system and the interface against any kind of security breach, unauthorized access, interference, intrusion, leakage and/or theft of data or information. ABB and its affiliates are not liable for damage and/or losses related to such security breaches, unauthorized access, interference, intrusion, leakage and/or theft of data or information.

1. INTRODUCTION

1.1. Scope

This manual describes the characteristics of Lite Panel, including:

1. Introduction
2. Hardware
3. Lite Panel icon description
4. Lite Panel functions
5. Firmware upgrade
6. Troubleshooting
7. Annex

For optimum installation and applicate of Lite Panel in the plant, the following tasks in Table 1 should be performed in sequence.

Table 1 Task list

| Number | Task | Remarks |
|--------|----------------------------|---|
| 1 | Consult the safety notes | |
| 2 | Check operating conditions | Check custom's field operating conditions |
| 3 | Check material received | Check the Lite Panel hardware and accessory |
| 4 | Installation Lite Panel | Please refer 2.1 |
| 5 | Parameters configuration | Please refer 4.3 |
| 6 | Scan field devices | Please refer 4.4 |
| 7 | Monitoring | Please refer 4.5 |

1.2. Application

Lite Panel is an industry control panel which provides user a better way to monitor and control the ABB low voltage devices for the facility.

Main features of the Lite Panel are as below:

- Real time monitoring of electrical measurement
- Supervision and control functions
- Fault detection and diagnose information checking

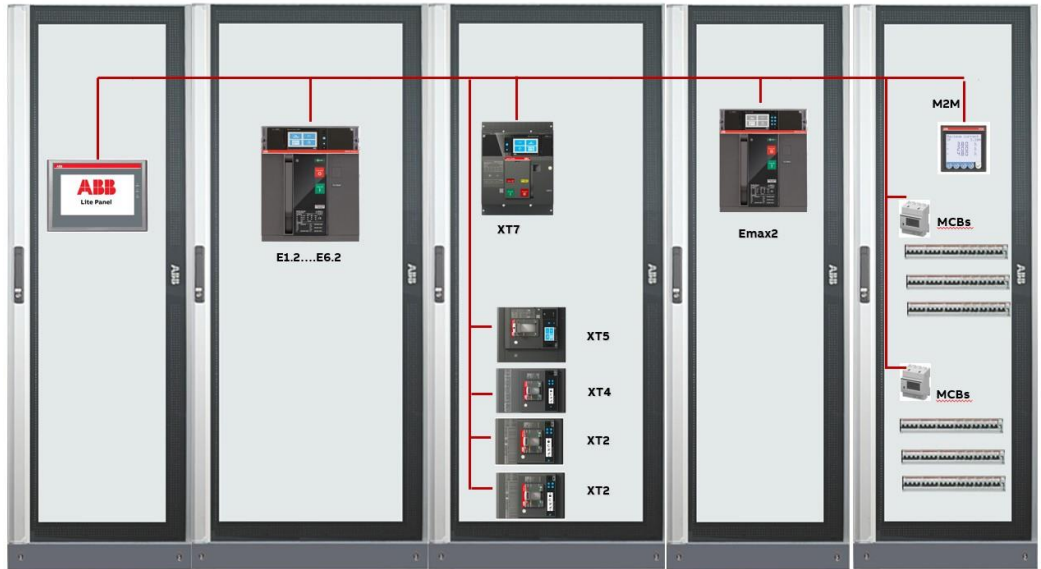

Figure 1 Application Example

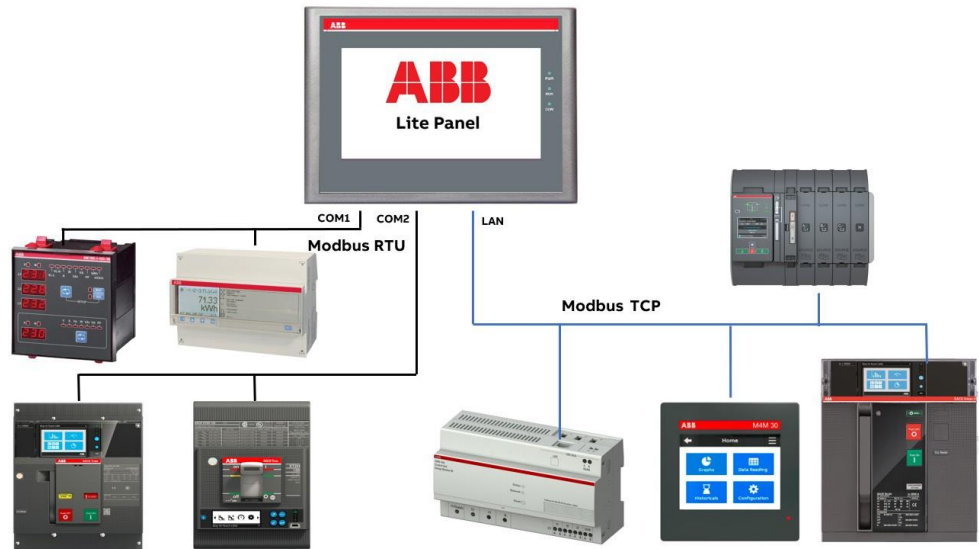

Figure 2 Topology Example

i **Notes:** Lite Panel and Modbus TCP devices should be connected in the customer's private network.

1.3. Supported devices

Lite Panel supports many types of ABB low voltage devices. Table 2 list all the supported devices.

Table 2 Supported devices

| Device family | Unit type | COM | Ethernet |
|----------------|---|------------------|------------------|
| Tmax XT | Ekip E-LSIG | √ ^[1] | |
| | Ekip LSI | √ ^[1] | |
| | Ekip M-LRIU | √ ^[1] | |
| | Ekip LSI | √ ^[1] | |
| | Ekip Touch, Ekip Hi Touch | √ ^[2] | √ ^[3] |
| Emax 2 | Ekip LCD/Hi-LCD, Ekip G LCD/G Hi-LCD (M3, M4 series) | √ ^[2] | √ ^[3] |
| | Ekip Touch/Hi-Touch, Ekip G Touch/G Hi-Touch (M3, M4 series) | √ ^[2] | √ ^[3] |
| Ekip UP | Monitor, Protect, Protect+, Control, Control+ | √ ^[2] | √ ^[3] |
| M2M | M2M RTU | √ | |
| | M2M Ethernet | | √ |
| DMTME | DMTME-I-485-96 | √ | |
| CMS700 | CMS700 | √ | √ |
| Fuse Gear ITS2 | ITS2 | √ | |
| TruOne ATS | TruONE ATS Level 4 (Touch) | √ ^[2] | √ ^[3] |
| | TruONE ATS Level 3 (LCD) | √ ^[2] | √ ^[3] |
| IM300 | IM300, IM301, IM302, IM303 | √ | |
| EQmeters | A Series-- A44, A43 | √ | |
| | B Series-- B21, B23 | √ | |
| M4M | M4M 20 Series | √ | √ |
| | M4M 30 Series | √ | √ |
| M1M/ M1M C | M1M 15 Series | √ | |
| | M1M 20 Series | √ | |
| | M1M 30 Series | √ | |
| CM-TCN.012 | CM-TCN.012 | √ | |
| SCU100 | SCU100 | | √ |
| Emax 3 | Ekip LCD/Hi-LCD, Ekip G LCD/G Hi-LCD (M3, M4 series) | √ ^[2] | √ ^[3] |
| | Ekip Touch/Hi-Touch, Ekip G Touch/G Hi-Touch (M3, M4 series) | √ ^[2] | √ ^[3] |

i Notes: "COM" shows that device is possible to communicate via Modbus RTU protocol, while "Ethernet" shows that device is possible to communicate via Modbus TCP protocol.

[1]: Required Ekip COM accessory

[2]: Required Ekip COM Modbus RTU module

[3]: Required Ekip COM Modbus TCP module

1.4. Software

General software functions of the Lite Panel are listed in table 3.

Table 3 Software functions

| Functions | Items | Remark |
|-----------------------------|---|---|
| Communication configuration | Modbus RTU | Max 16 devices (8 for each COM port) |
| | Modbus TCP | Max 20 devices |
| | Modbus TCP+ Modbus RTU | Max 20 + 8 devices |
| Discover field devices | Automatic scanning devices | ✓ |
| Supervision and control | Opening and closing remote control | Only for Circuit-breakers, Fuse gear or TruOne switches, exclude meters |
| | Device communication status | ✓ |
| Measure [1] | Currents | ✓ |
| | Voltages | ✓ |
| | Frequency | ✓ |
| | Power | ✓ |
| | Energy | ✓ |
| | Power factor | ✓ |
| | Harmonic | ✓ |
| | Network analyze | Tmax XT/Emax 2 (Ekip Hi-Touch/G Hi-Touch), Ekip UP |
| Information [1] | History data(Event log, Trip history, Measure history) | Emax 2, Ekip UP, Tmax XT(Touch/Hi Touch) |
| | Total Number of operations | ✓ |
| | Number of trips | ✓ |
| | Contact wear | ✓ |
| | Number of Manual Operations | ✓ |
| | Device Information (firmware version, serial number...) | ✓ |
| Diagnostic | State information (open/close, alarms) | ✓ |
| | Trips, warning, alarms | Emax 2, Ekip UP, TruOne ATS, ITS2, Tmax XT |
| | Device event log | Emax 2, Ekip UP, TruOne ATS Tmax XT(Touch/Hi Touch) |
| Language | Audit log | ✓ |
| | English language and Chinese language are supported | ✓ |

 **Notes:[1]** According to device family and unit type of the connected device.



2. HARDWARE

2.1 Hardware installation

2.1.1 Hardware installation condition

| Items | Description |
|-------------------------------|---|
| Places for application | Lite Panel is designed according to the environment of industrial products. Its design specification to work in the -20°C to 55°C in most industrial condition. |
| NEMA | The front panel of the Lite Panel match the NEMA4 protection regulations. When the product is properly installed in the disk cabinet match NEMA4 protective provisions, the enclosure remains committed to comply with the provisions of the NEMA4, that is, when the enclosure surface spray liquid, the liquid does not penetrate inside the enclosure. |
| Electrical condition | Lite Panel has been tested to meet the European CE standard. Circuit design is resistant to electrical noise interference, but that does not guarantee that can remove all the electrical noise interference. The correct way of wiring and grounding to ensure correct use. |
| Mechanical condition | To ensure that your correct use of the Lite Panel products, avoid installation in the condition of strong mechanical vibration (see details in the section 2.2.2). |

2.1.2 Hardware installation guide

| Items | Description |
|--|---|
| <p>Install location</p> | <p>While install equipment's behind the Lite Panel, make sure the AC power wiring, PLC output modules, contactors, starters, relays, and other types of electrical interface equipment farther to the back of the distance of the Lite Panel. Keep away of inverter and switching power supply, the input and output of such equipment must be shielded and connected to the system star point.</p> |
| <p>Install meet NEMA4 Standards</p> | <p>Specifications Lite Panel can be installed in the disk cabinet depth of more than 50 to 75mm (depending on the thickness of the product), it is recommended you install Lite Panel in the front panel of enclosure, do this in order not to affect you open the enclosure front panel and assurance you can smoothly connect the power and communications cables.</p> <p>NEMA4 Installation Put product into the Mounting holes from the back of the panel, install screws into the product of 4 fixed holes shell around the product, and then one by one lock mounting screws until the product is securely fixed to the panel on the panel.</p> <p>Warning! Do not fasten the mounting screw with too much strength or the screen will be damaged. (Maximum Torque: 0.2N·m).</p> <p>Warning! In order to ensure the packing specification, all mounting screws provided with products must be used. The curvature of the front-panel cannot be over 0.010". With fixed bolt fixed Lite Panel, please use the insulating sleeve to prevent leakage of the machine it may cause damage to the Lite Panel.</p> |
| <p>Environmental Considerations</p> | <p> Because of the LCD display inside, the Lite Panel must be used indoors. Make sure the product is installed correctly and the environment meet.</p> <p> Do not use in explosion hazard situations, such as the presence of flammable gas, vapor or dust.</p> <p> Do not use in the temperature or high humidity environment (see details in the section 2.2.2), which may cause the device internal product condensate, resulting in damage to the equipment.</p> |

2.1.3 Power connection

| Items | Description |
|------------------------|--|
| Power requirement | <p>⚠ Power Lite Panel products can only use the DC power supply, the provision of the DC voltage range is 24±15% volts of power. This ensures compatibility with most controller DC power supply system. Products within the power regulator circuit is completed by the switching power supply. If the product within two seconds after power display is not shown, please disconnect the power immediately. Check the wiring is correct before re-energized. DC power supply must be properly isolate with the main AC power.</p> <p>⚠ Warning! In order to comply with ICs Safety Recommendations, you must install an emergency stop switch while use Lite Panel in your control system.</p> <p>⚠ Warning! Power Do not share the power between Lite Panel and inductive load (such as solenoid switch or solenoid valve).</p> <p>⚠ Warning! Wiring Some controller 24V DC output power supply cannot provide the current needed of Lite Panel DC power supply line should be as short as possible (up to no more than 500m for shielded cable 300m for UTP).tools, Please take the appropriate lightning protection measures when lightning occurs frequently Be sure AC power cables and high-energy and rapidly switching DC wiring separate from signal cable. Put a resistance and a capacitance in parallel between the around and the DC insulated power without earthing. This will make a path for static electricity and high-frequency interference. (Suggestions: Resistance, 1MΩ; Capacitance, 4700pF)</p> <p>⚠ Connection Unscrew the screws of line terminal anticlockwise on rear panel. Insert the power cable. Then fasten the screws clockwise. Please insert the power cable laterad when unscrew the plugin line terminal anticlockwise. Then fasten the screws clockwise. Put the terminals into the slot on the rear panel. Caution: Connect the positive pole to the terminal marked “24VDC+” and connect the DC GND to the terminal marked “24VDC-”.</p> |
| Grounding Requirements | <p>Product shell must be grounded, DC in the inside of the product is not connected to the actual earth. In order to avoid due to the virtual point grounding can introduce noise into the system, it is best not to land and housing of the DC to earth, but if you have to power to received star point, you must ensure that the ground wire as short as possible cross-sectional area as far as possible.</p> |
| CE Requirement | <p>To ensure Lite Panel meet EMC specifications, reducing the electrical noise interference, the product of the power terminals on the chassis ground terminal must be connected to a separate # 14 AWG grounding cable. This ground connection must follow the installation instructions directly connected to the system star ground point.</p> |

| Items | Description |
|----------------------------|---|
| <p>Safety Guide</p> | <p>This section presents recommended installation practices and procedures. Although there is no any two applications are the same, but please carefully consider the following recommendation when installing.</p> <p>⚠ Warning! Hardware Install Proposal The system designer must understand that equipment controller system may malfunction and produce insecurity, electrical conflict and Lite Panel (for example. HM/EA) may lead to the run of the device, which may lead to a certain damage to the body of the operator.</p> <p>If you or your company use programmable control system that require Lite Panel, you must understand the potential security risks and take appropriate preventive measures. Despite your detailed design procedure is developed based on your specific application, but also need to pay attention to the following information about programmable control equipment installed universal precautions, these precautions in line with the NEMA ICS 3-304 Control standards recommended by the controller installation specification.</p> <p>⚠ Program In order to meet the security recommendations of the ICS, check and make sure the emergency stop writable register have security restrictions and safety equipment will exceed the limit conditions of the control of the dangerous parts of the plant or equipment in the program to ensure personal absolutely safe.</p> <div style="border: 1px solid black; padding: 10px; margin: 10px 0;"> <p>ICS 3-304.81 safety recommendations: In the mechanical parts that the operator can touch, such as the location of loading machine mechanical automatic operation, you must carefully consider the override or other redundant means, it must be independent out of the programmable controller. You can start or stop the automatic operation of the system. If you need to modify the program on system running a lock or other measures must be considered to ensure that only authorized people can make the necessary security measures to security threats. * These recommendations are intended to prevent the risk of equipment failures and the safety measures when modify the program online.</p> </div> <ul style="list-style-type: none"> • 1CS3-30481 safety recommendations are copied from the NEMA. under license from NEMA ICS3-304 standards |

2.1.4 CE Requirement

Lite Panel conforms with the EMC regulations.

- EMC (electromagnetic compatibility) regulations electromagnetic interference radiation and resistance.
- Lite Panel has CE marking and conforms with the EMC regulations

Lite Panel is designed to ensure it can be worked in the standard limit electromagnetic noise environment (resistance) and does not produce high-intensity electromagnetic noise radiation to the surrounding environment (radiation). Installed correctly in accordance with the instructions in this manual, the product in full compliance with electrical safety standards of the European Community.

Compatibility standard

Lite Panel are designed to meet the industrial environment and electromagnetic compatibility.

- EN 55032, Group 1, Class A in radiation levels
- EN 55032 radiation standard for industrial environment (equivalent to U.S. FCC Class A standards)
- EN55035 standard for generic resistance of industrial environment.

2.1.5 Installation diagram

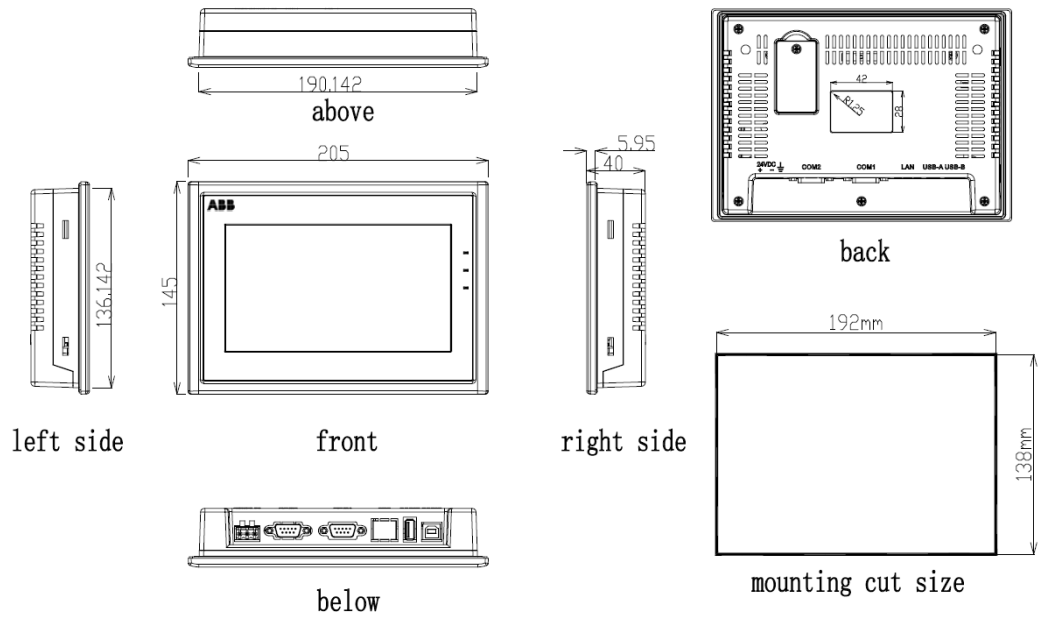

Figure 3 Installation diagram

2.2 Hardware introduction

2.2.1 Hardware structure

Front panel



Figure 4 Front panel

The front panel consists of the display screen and the operation indicator lights. Table 4 shows the display status of the three LED indicator lights on different working state.

PWR turns green when it is powered;

RUN turns yellow if CPU works normally while it lights out if CPU fails;

COM flashes yellow when the touch screen is communication with field devices.

Table 4 LED indicator

| Device state | Green LED (PWR) | Yellow LED (RUN) | Yellow LED (COM) |
|-------------------------------------|-----------------|------------------|------------------|
| No power supply | ○ | ○ | ○ |
| Power on | ● | | |
| CPU running | ● | ● | |
| Communication with connected device | ● | ● | ※ |

○ LED OFF; ● LED ON; ※ LED flashing

Back panel



Figure 5 Back panel

The Lite Panel's tag with serial number is pasted on the back panel of the machine.

Bottom panel

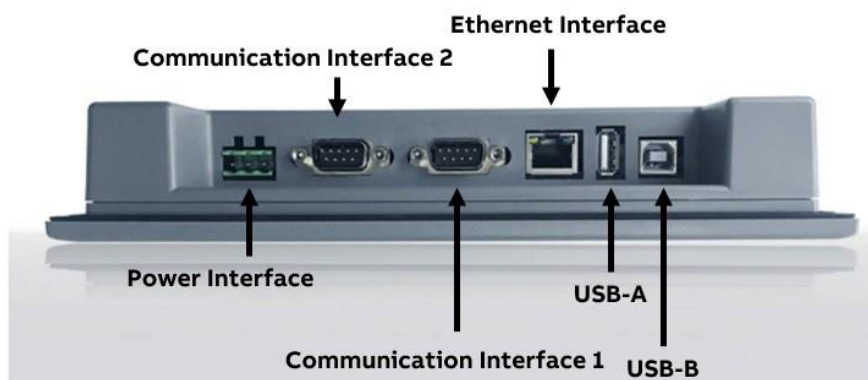

Figure 6 Bottom panel

The communication interfaces of the Lite Panel are located in the bottom panel of the machine.

Power Interface: Connection of DC24V power supply;

Ethernet Interface: Connection of Ethernet cable to communicate with Modbus TCP devices;

USB-A and USB-B: Not available for customer;

Communication Interface 1 and 2: They are 9-pin communication interface which supports communicate with ABB Modbus RTU devices via RS485. Refer to Figure 7 for the correct wiring.

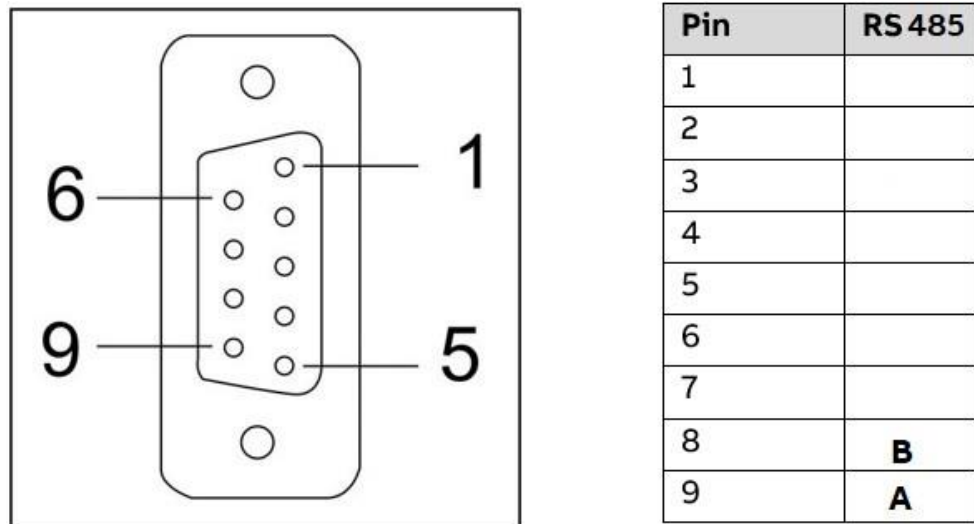

Figure 7 9-Pin definition

2.2.2 Hardware parameter















Table 5 Hardware parameter





| | | |
|---------------------------------|------------------------|------------------------|
| Hardware | Outline dimension | 203×145×40 |
| | Cut-out Size | 192×138 |
| | Net Weight | 0.78Kg |
| Display | Display Size | 7" (16:9) |
| | Resolution (Px) | 800×480 |
| | Color | 262114 |
| | Contrast Ration | 400: 1 |
| | Luminance | 450cd/m2 |
| | Backlight | LED |
| Touch Screen | Resistive | Four-wire screen |
| Properties/Certification | Memory | 128M FLASH + 128M DDR2 |
| | CPU | Cortex A8 600MHz |
| | Electric Strength Test | 500V DC, 1min |
| | ESD | Level4 ± 8kV |
| | FCC | FCC, Class A |
| | CE | EN55032 & EN55035 |
| | Protection Grade | IP65 (Front panel) |
| | Housing Material | ABS + PC |
| Power/Port | Power supply | DC24V(±15%) |
| | Power Consumption | 6W |
| | Series Port | 2*RS485 |
| | Ethernet Port | 1 |
| Environment | Operation Temperature | -20 ~ 55 °C |
| | Operation Humidity | 5 ~ 95%RH |
| | Shockproof | 10 ~ 25Hz |

 If you have special application requirement, please contact ABB











3. Lite Panel ICON DESCRIPTION

Table 6 Lite Panel Icon description

| Home page Icon | Description |
|---|---|
|  | Total monitored devices number. Gray means no device shown on the home page. |
|  | Communication good devices number. Gray means no device communication is good. |
|  | Devices number with alarm. Gray means no device has alarm. |
|  | Help icon. Access the help information page, can view current software version. |
|  | User icon. Gray means no user logged in. |
|  | User logout. |
|  | Green means that current device is connected on ethernet and communication good. Red means that current device is connected on ethernet and communication has problem. |
|  | Green means that current device is connected on COM1 and communication good. Red means that current device is connected on COM1 and communication has problem. |
|  | Green means that current device is connected on COM2 and communication good. Red means that current device is connected on COM2 and communication has problem. |
| Home Page Alarm Icon | Description |
|  | Green means device has no alarm. Orange means device has warning. Red means device has alarm. |
| Alarm list Icon | Description |
|  | This is alarm message. |
|  | This is warning/ pre-alarm/error/trip message. |
|  | This is timing message. |
|  | This is information. |
| Operation Icon | Description |
|  | Close the circuit-breaker/switch. Gray means "Push ON" button is not allowed to be executed. |

| | |
|---|---|
|  | <p>Open the circuit-breaker/switch. Gray means "Push OFF" button is not allowed to be executed.</p> |
|  | <p>Switch the TruOne ATS to source I . Gray means "Switch to source I " button is not allowed to be executed.</p> |
|  | <p>Switch the TruOne ATS to OFF. Gray button means "Switch to OFF" button is not allowed to be executed.</p> |
|  | <p>Switch the TruOne ATS to source II . Gray button means "Switch to source II" button is not allowed to be executed.</p> |
|  | <p>Reset trip unit. Gray button means "Trip unit Reset" button is not allowed to be executed.</p> |

i Notes: The operation button will show gray when the device is in "local" control mode or the logged in user do not have the access of remote operation. Please refer to 4.1.1 for checking user's access and refer to 4.5.3 for device's remote control.

| Setting Icon | Description |
|---|--|
|  | <p>Select/deselect a scan mode.</p> |
|  | <p>Select/deselect a device.</p> |
|  | <p>On/off or enable/disable related mode.</p> |
|  | <p>Setting</p> |
|  | <p>Click the button to restart Lite Panel</p> |
| Navigate Icon | Description |
|  | <p>Enter next</p> |
|  | <p>Enter previous</p> |
|  | <p>Enter to</p> |
|  | <p>Audit log</p> |
| Forbidden Icon | Description |
|  | <p>Some menus or buttons attached with forbidden icon means that the function is not accessible. The forbidden icon will disappear after login with higher privilege user.</p> |

4. Lite Panel FUNCTIONS

4.1 Lite Panel user management

There are five users with different privilege in the Lite Panel: Administrator, Developer, Engineer, Operator, Guest.

As default only “Administrator” account is enabled in Lite Panel. To enable other users, please refer 4.3 for detail.

4.1.1 User privilege

Table 7 shows user’s privilege and related functions.

Table 7 Users privilege matrix

| | Devices Management | System General Setting | Enable/Disable users | User Password Administer | Device Operation | Enter Device Details |
|---------------|--------------------|------------------------|----------------------|--------------------------|------------------|----------------------|
| Administrator | √ | √ | √ | √ | √ | √ |
| Developer | √ | √ | X | X | X | √ |
| Engineer | X | √ | X | X | √ | √ |
| Operator | X | X | X | X | √ | √ |
| Guest | X | X | X | X | X | √ |
| Not login | X | X | X | X | X | X |

Remarks:

Devices Management: This function indicates that the user has the access to scan devices and start/stop monitoring devices. Please refer 4.4 for detail.

System General Setting: This function indicates that the user has the access to do some general settings such as “IP setting”, “Sound on/off setting”. Please refer 4.3 for detail.

Enable/Disable users: This function indicates that the administrator has the privilege to enable or disable other users. Please refer 4.3 for detail.

User Password Administer: This function indicates that the administrator has the privilege to change all user’s login password.





Device Operation: This function indicates that the user has the access to remote operate devices. Please refer 4.5.3 for detail.

Enter Device Details: This function indicates that the user has the access to view all devices’ details after login.

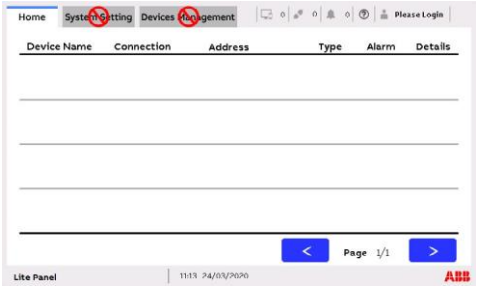

IMPORTANT: Only the administrator has the privilege to enable or disable other users and has the privilege to change all user’s password. It is suggested administrator modify all the default password after first login. Please take good care of the password and inform related user after making any change.

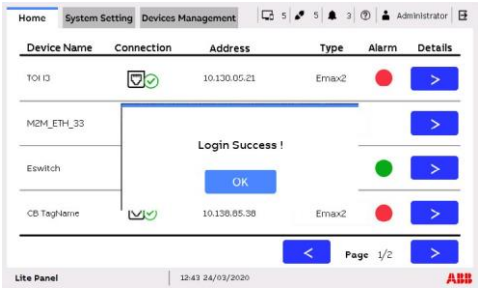
4.1.2 User login

| Items | Description | Picture |
|-----------------|---|---|
| Not Logged in | <p>Lite Panel default is no login after reboot.</p> <p>It is not allowed to access any device's detail pages and do any setting without login.</p> |  |
| Login | <p>Click the “Please Login” from home page. Select related user and input the correct password and login.</p> <p>As default only “Administrator” account is enabled in Lite Panel. To enable other users, please refer 4.3 for detail.</p> <p>Default password for each user as follow: Administrator:1111 Developer:2222 Engineer:3333 Operator:4444 Guest:5555</p> <p>It will popup “Login success!” when the selected user and the inputted password is matched.</p> <p>On the contrary, panel will warn “Login fail!”.</p> <p>If continuously input wrong password for three times, current user will be locked for 30 minutes.</p> |   |
| Manually Logout | <p>To logout the Lite Panel, please click the  button on upper-right corner.</p> | |
| Auto logout | <p>For security consideration, the Lite Panel will auto logout after 30 minutes if there is no execution on the Lite Panel.</p> | |
| Switch user | <p>To switch user, please logout current user first, then follow above Lite Panel Login to login with other user.</p> | |

4.1.3 Factory reset for password

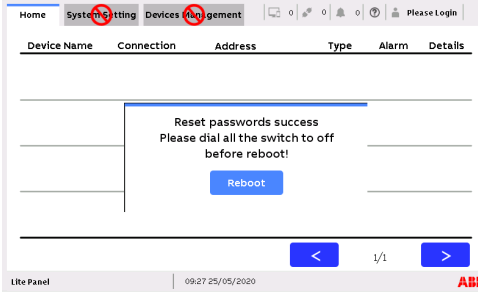
| Steps | Description | Picture |
|-----------------------------|---|--|
| Dial the switch on hardware | <p>If the “Administrator” forgot the login password for the lite panel. There is one way to do the factory reset from hardware</p> <ol style="list-style-type: none"> ① Power off the panel ② Open the cover from back panel ③ Dial the second DIP switch from off to on |  |
| Password Reset | <ol style="list-style-type: none"> ① Power on the panel and wait about 10s, there will be a message popup. ② Dial the second DIP switch from on to off ③ Click “Reboot” to finish the process |  |
| Password Verify | <p>After finish reboot, try to login the lite panel with factory default password.</p> <p>Default password for each user as follow:</p> <ul style="list-style-type: none"> Administrator:1111 Developer:2222 Engineer:3333 Operator:4444 Guest:5555 | |

4.2 Lite Panel home page introduction

“Home” page is used to show the basic information of all monitoring devices.

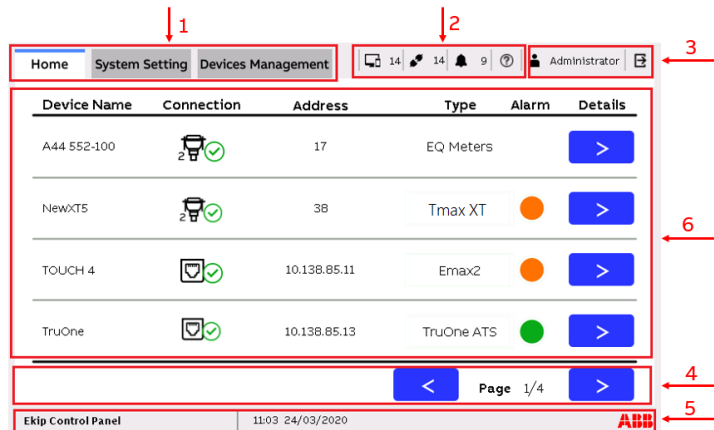

Figure 8 Lite Panel home page

With “Home” page, it’s possible to have the following information:

| Area | Items | Description |
|------|-----------------------------|---|
| 1 | Menu bar | “Home”, “System setting” and “Devices Management” three menus are provided to access each application. |
| 2 | Status bar | Show the number of devices monitored; number of devices connected; number of devices with alarm. ? Help icon to get help information |
| 3 | Login/Logout | Button for user to login/logout. |
| 4 | Device list page | Show the current page number and total pages number. Buttons to navigate to previous/next page of devices. |
| 5 | Footer | Show product name, system time and ABB Logo. |
| 6 | Devices general information | Device name: <ul style="list-style-type: none"> • Device name read from physical device. • If there is no defined name from device, it will be shown as “device type_Connect port_address”. For example: <ol style="list-style-type: none"> a. CMS700_COM1_200 stands for COMS700 with slave address 200 and connected on COM1; b. M2M_ETH_123 stands for M2M with host IP 123 and connected on Ethernet. Connection: Show device connection status and communication type. Address: Show slave address for Modbus RTU devices and show IP address for Modbus TCP devices. Type: Device type as ABB defined. Please refer to table 2 Supported devices. Alarm: <ul style="list-style-type: none"> ● : Indicate no alarm ● : Indicate warning ● : Indicate alarm Blank: Indicate this type of device does not support alarm function. Details: Button to navigate to device detail information page. |

4.3 Lite Panel system setting

“System setting” page provides some basic configuration for the Lite Panel.

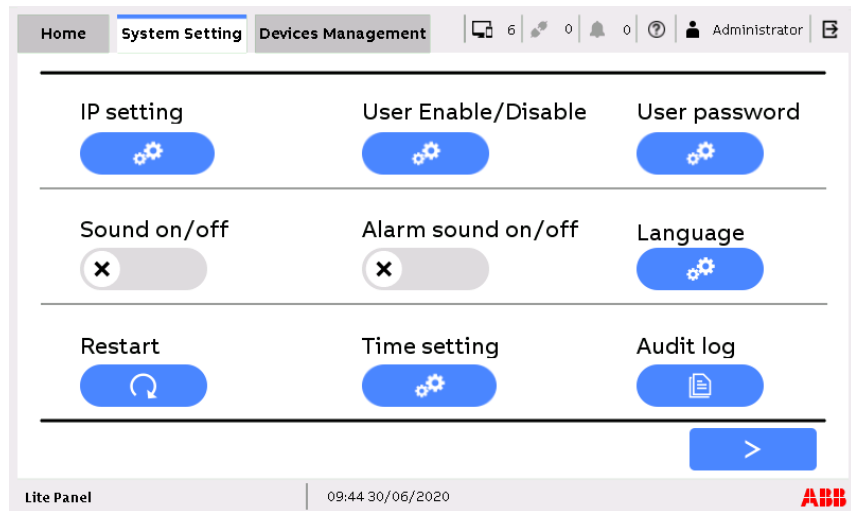

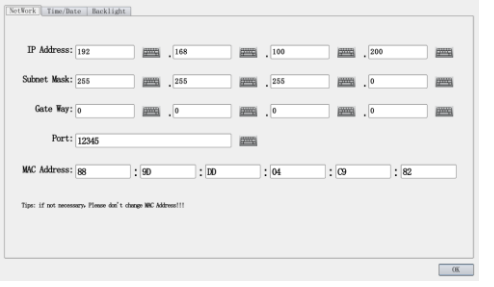
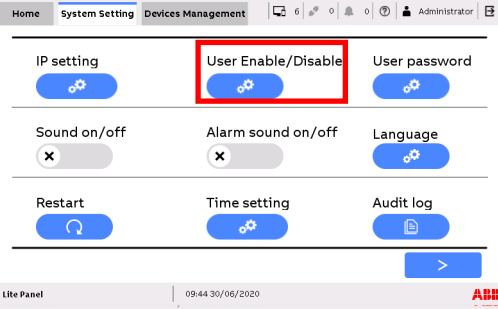
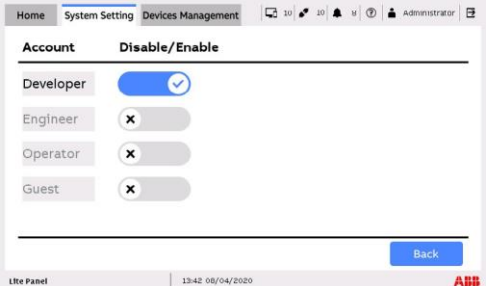
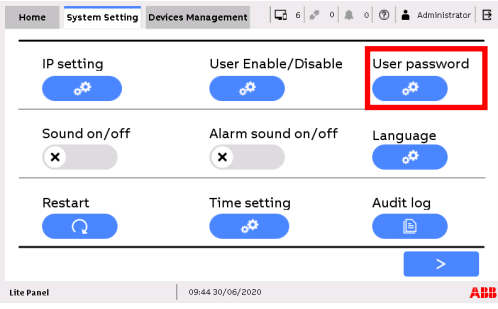

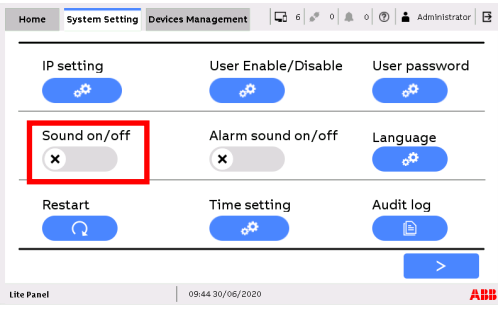

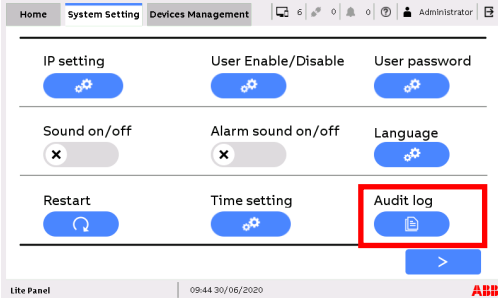
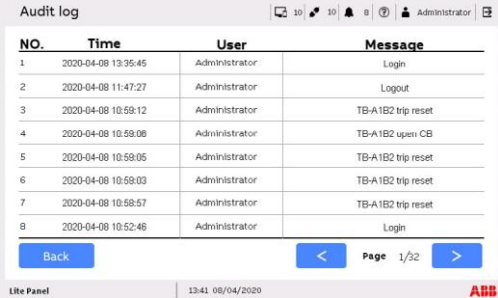

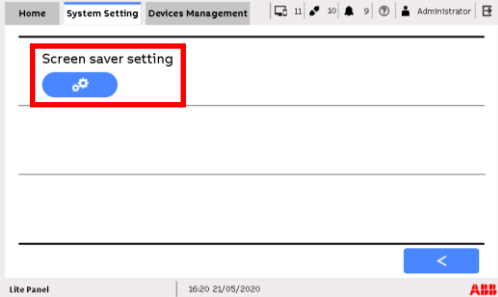

Figure 9 System setting

| Items | Description | Picture |
|-------------------|---|--|
| <p>IP setting</p> | <p>The Lite Panel cannot automatically get IP from your LAN network. Please set the Lite Panel a static IP address in the same LAN as the Modbus TCP device.</p> <ol style="list-style-type: none"> ① Access “System Setting” ② Click “IP setting”  ③ Set the IP Address, Subnet Mask, Gateway according your network configuration. ④ Then click “OK” button and the Lite Panel will require to reboot; ⑤ IP address will update after reboot. |  |

| Items | Description | Picture |
|----------------------------|---|--|
| <p>User Enable/Disable</p> | <p>Only the “Administrator” has the privilege to enable or disable other users.</p> <ol style="list-style-type: none"> ① Login as administrator ② Access the “System Setting” ③ Click “User Enable/Disable” ④ Click the button to enable or disable related account. |   |
| <p>User password</p> | <p>Only the “Administrator” has the privilege to change password for other users.</p> <ol style="list-style-type: none"> ① Login as administrator ② Access the “System Setting” ③ Click “User password” ④ Input new password and confirm password, click ⑤ It will pop out the message “Modify password success!”. |   |
| <p>Sound on/off</p> | <p>Access the “System Setting”</p> <p><input checked="" type="checkbox"/> : Enable the sound when touching the screen;</p> <p><input type="checkbox"/> : Disable the sound when touching the screen.</p> |  |

| Items | Description | Picture |
|--------------------|---|--|
| Alarm sound on/off | <p>Access the “System Setting”</p> <p> : Enable a beeper when alarm occur;</p> <p> : Disable a beeper when alarm occur.</p> |  |
| Language | <p>① Access the “System Setting”</p> <p>② Click “Language” </p> <p>③ It will popup a window, select the English or Chinese and click OK.</p> |  |
| Restart | <p>① Access the “System Setting”</p> <p>② Click button  to restart the Lite Panel.</p> |  |
| Time setting | <p>① Access the “System Setting”</p> <p>② Click “Time setting” </p> <p>③ Set time for Lite Panel.</p> |  |

| Items | Description | Picture | | | | | | | | | | | | | | | | | | | | | | | | | | | | | | | | | | | | |
|-----------------------------|--|--|--------------------|------|------|---------|---|---------------------|---------------|-------|---|---------------------|---------------|--------|---|---------------------|---------------|--------------------|---|---------------------|---------------|-----------------|---|---------------------|---------------|--------------------|---|---------------------|---------------|--------------------|---|---------------------|---------------|--------------------|---|---------------------|---------------|-------|
| <p>Audit log</p> | <p>Audit log helps record user's login/logout and user's remote control logs.</p> <ol style="list-style-type: none"> ① Access the "System Setting" ② Press the "Audit log"  button to view all the audit log in Lite Panel. |   <table border="1" data-bbox="1018 685 1485 887"> <thead> <tr> <th>NO.</th> <th>Time</th> <th>User</th> <th>Message</th> </tr> </thead> <tbody> <tr> <td>1</td> <td>2020-04-08 13:35:45</td> <td>Administrator</td> <td>Login</td> </tr> <tr> <td>2</td> <td>2020-04-08 11:47:27</td> <td>Administrator</td> <td>Logout</td> </tr> <tr> <td>3</td> <td>2020-04-08 10:58:12</td> <td>Administrator</td> <td>TB-A1B2 trip reset</td> </tr> <tr> <td>4</td> <td>2020-04-08 10:59:08</td> <td>Administrator</td> <td>TB-A1B2 open CB</td> </tr> <tr> <td>5</td> <td>2020-04-08 10:58:05</td> <td>Administrator</td> <td>TB-A1B2 trip reset</td> </tr> <tr> <td>6</td> <td>2020-04-08 10:59:03</td> <td>Administrator</td> <td>TB-A1B2 trip reset</td> </tr> <tr> <td>7</td> <td>2020-04-08 10:58:57</td> <td>Administrator</td> <td>TB-A1B2 trip reset</td> </tr> <tr> <td>8</td> <td>2020-04-08 10:52:48</td> <td>Administrator</td> <td>Login</td> </tr> </tbody> </table> | NO. | Time | User | Message | 1 | 2020-04-08 13:35:45 | Administrator | Login | 2 | 2020-04-08 11:47:27 | Administrator | Logout | 3 | 2020-04-08 10:58:12 | Administrator | TB-A1B2 trip reset | 4 | 2020-04-08 10:59:08 | Administrator | TB-A1B2 open CB | 5 | 2020-04-08 10:58:05 | Administrator | TB-A1B2 trip reset | 6 | 2020-04-08 10:59:03 | Administrator | TB-A1B2 trip reset | 7 | 2020-04-08 10:58:57 | Administrator | TB-A1B2 trip reset | 8 | 2020-04-08 10:52:48 | Administrator | Login |
| NO. | Time | User | Message | | | | | | | | | | | | | | | | | | | | | | | | | | | | | | | | | | | |
| 1 | 2020-04-08 13:35:45 | Administrator | Login | | | | | | | | | | | | | | | | | | | | | | | | | | | | | | | | | | | |
| 2 | 2020-04-08 11:47:27 | Administrator | Logout | | | | | | | | | | | | | | | | | | | | | | | | | | | | | | | | | | | |
| 3 | 2020-04-08 10:58:12 | Administrator | TB-A1B2 trip reset | | | | | | | | | | | | | | | | | | | | | | | | | | | | | | | | | | | |
| 4 | 2020-04-08 10:59:08 | Administrator | TB-A1B2 open CB | | | | | | | | | | | | | | | | | | | | | | | | | | | | | | | | | | | |
| 5 | 2020-04-08 10:58:05 | Administrator | TB-A1B2 trip reset | | | | | | | | | | | | | | | | | | | | | | | | | | | | | | | | | | | |
| 6 | 2020-04-08 10:59:03 | Administrator | TB-A1B2 trip reset | | | | | | | | | | | | | | | | | | | | | | | | | | | | | | | | | | | |
| 7 | 2020-04-08 10:58:57 | Administrator | TB-A1B2 trip reset | | | | | | | | | | | | | | | | | | | | | | | | | | | | | | | | | | | |
| 8 | 2020-04-08 10:52:48 | Administrator | Login | | | | | | | | | | | | | | | | | | | | | | | | | | | | | | | | | | | |
| <p>Screen Saver setting</p> | <ol style="list-style-type: none"> ① Access the "System Setting" ② Click  to access next page ③ Click "Screen saver setting" ④ Set screen saver time for Lite Panel. |  | | | | | | | | | | | | | | | | | | | | | | | | | | | | | | | | | | | | |

4.4 Lite Panel device management

Lite Panel *Device management* page provides the user the ability to scan for connected devices via Modbus RTU and Modbus TCP protocol.

Lite Panel has the capability to communicate with about 20 devices. For the communication configuration please refer to table 3.

4.4.1 Scan devices via Modbus TCP

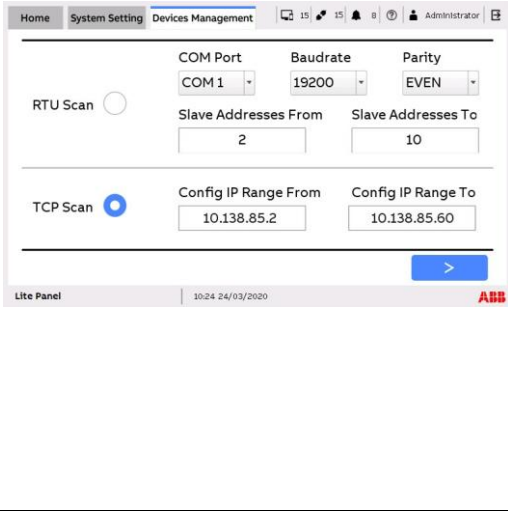
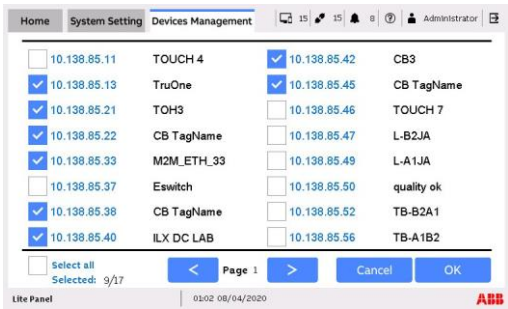
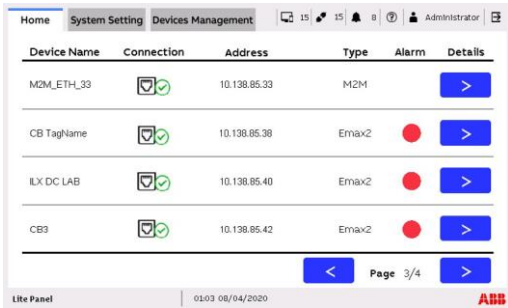
| Step | Action | Picture |
|------|---|--|
| 1 | <p>Login the Lite Panel. For user's scan device privilege, please refer to 4.1.1</p> <ol style="list-style-type: none"> ① Click the menu "Devices Management" ② Select "TCP Scan" ③ Input appropriate IP address range ④ Press "Next"  button to start scan. <p>Notes: the IP addresses must in the same subnet, E.g., 192.168.1/24. And the range should be less than 250.</p> |  |
| 2 | <p>The discovered Modbus TCP devices will be showed after Lite Panel finishes the scanning process.</p> <ol style="list-style-type: none"> ① Select the Modbus TCP devices you want to monitor in the Lite Panel. ② Click "OK". |  |
| 3 | <p>The Lite Panel will save the selected devices' configuration and list these devices on the "Home" page.</p> |  |

4.4.2 Scan devices via Modbus RTU

There are two independent COM ports for Lite Panel which can independently work at the same time. It supports connecting Modbus RTU devices via different COM port with independent configuration. For example, it works fine to connect devices with baudrate of 9600 bit/s, Odd parity, slave address from 2-6 in COM1. And then connect devices with baudrate of 19200 bit/s, Odd parity and slave address from 2-6 in COM2.

Table 8 COM Port parameter setting

| Items | Parameter |
|---------------------------|--|
| COM Port | COM1, COM2 |
| Baudrate (bit per second) | 1200,2400,4800,9600,19200,38400,57600,115200 |
| Parity | None, Even, Odd |
| Slave address | 1-247 |

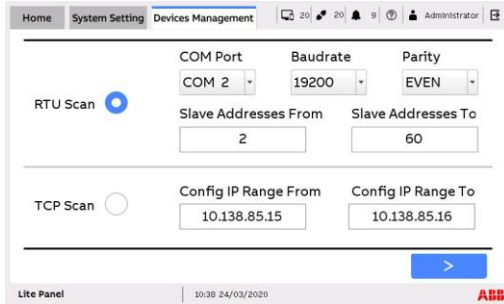
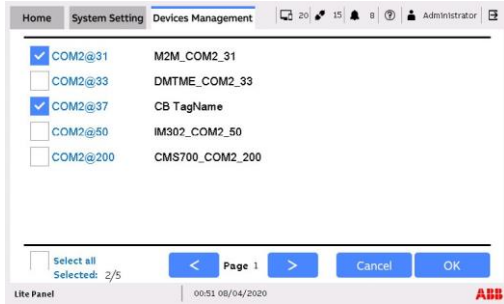
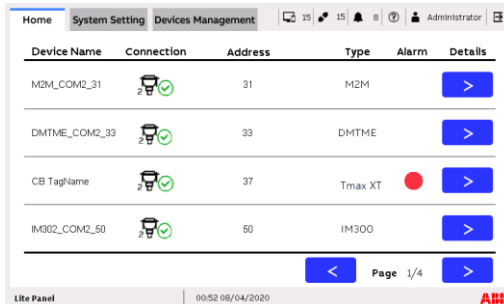
| Step | Action | Picture |
|------|---|--|
| 1 | <p>Login the Lite Panel. For user’s scan device privilege, please refer to 4.1.1</p> <p>① Click the menu “Devices Management”</p> <p>② Select “RTU Scan”,</p> <p>③ Set the corresponding serial configuration like port, baud rate and parity</p> <p>④ Set a range for RTU slave addresses.</p> <p>⑤ Finally press “Next”  button to start scan.</p> |  |
| 2 | <p>The discovered Modbus RTU devices will be showed after Lite Panel finish the scanning process.</p> <p>① Select the Modbus RTU devices you want to monitor in the Lite Panel.</p> <p>② Click “OK”.</p> |  |
| 3 | <p>The Lite Panel will save the selected devices’ configuration and list these devices on the “Home” page.</p> |  |

4.4.3 Delete device

If the user no longer wants to monitor a device and wants to delete it from the system, this can be found under “Device Management”. Rescan for connected devices, deselect it from the device list and click “OK”, the new configuration will be saved.

4.5 Device monitor and remote control

A device list page will be showed on Home page after scan, press the corresponding details button  of the device to monitor more detailed information.

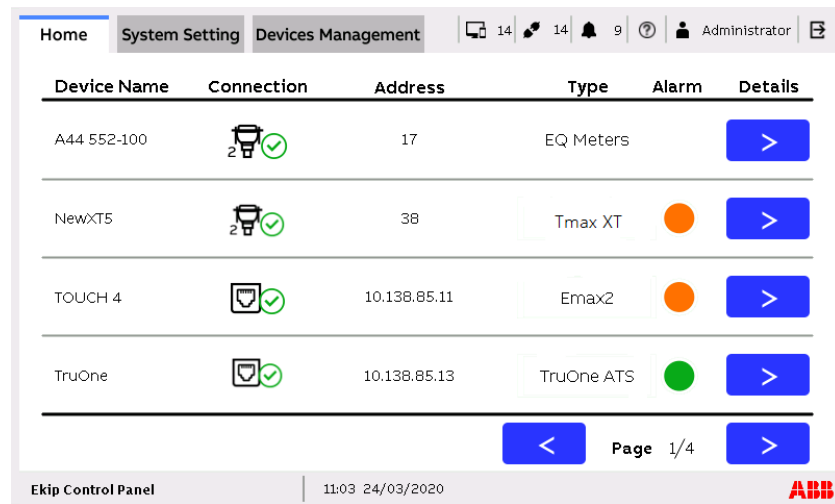

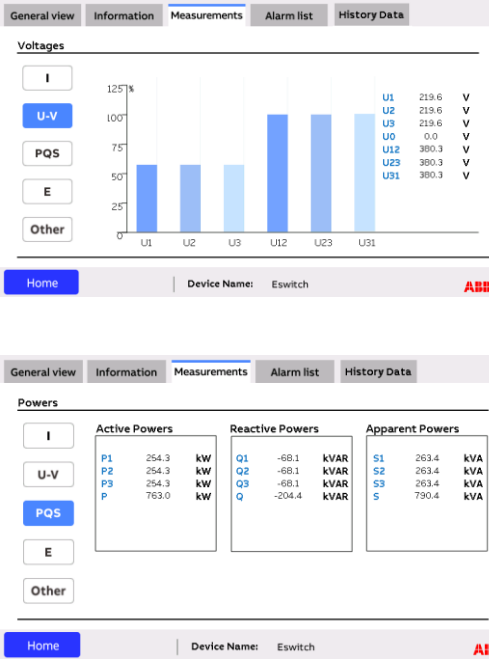
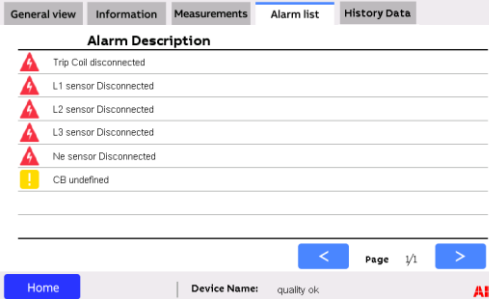
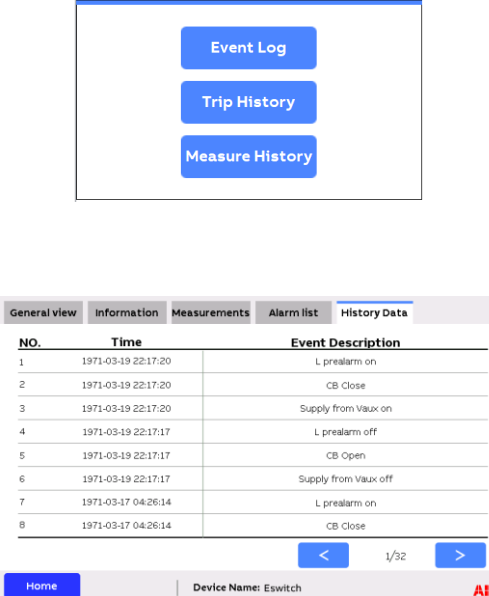

Figure 10 Device list page

4.5.1 Device monitor pages

| Device page | Description | Picture |
|--------------|--|---------|
| General view | <p>Enter the device, it will show the “General view” page of the device.</p> <p>From “General view”, it shows the device’s picture, general measures. And some remote control command can be performed here.</p> | |
| Information | <p>From the “Information” page, it shows the device’s information like general parameter, status, electronics of the device.</p> <p>Click  button to access next page to get Ekip signaling module status if it is assembled on device.</p> | |

| Device page | Description | Picture | | | | | | | | | | | | | | | | | | | | | | | | | | | |
|----------------------------|--|---|-----|------|-------------------|---|---------------------|---------------|---|---------------------|----------|---|---------------------|---------------------|---|---------------------|----------------|---|---------------------|---------|---|---------------------|----------------------|---|---------------------|---------------|---|---------------------|----------|
| <p>Measurements</p> | <p>One of the most important advantages for the Lite Panel is continuously monitoring real time data.</p> <p>Submenus found in “Measurements” page.</p> <ul style="list-style-type: none"> I : Currents U-V : Voltages PQS : Active power (P), Reactive power (Q), Apparent power (S). E : Energies Other : Harmonic, power factor, frequency etc. <p>Switch to different submenu to view different measurements.</p> |  <p>The top screenshot shows the 'Measurements' page with the 'U-V' (Voltages) submenu selected. It displays a bar chart for voltages (U1, U2, U3, U12, U23, U31) and a list of values on the right: U1: 219.6 V, U2: 219.6 V, U3: 219.6 V, U12: 380.3 V, U23: 380.3 V, U31: 380.3 V.</p> <p>The bottom screenshot shows the 'Measurements' page with the 'PQS' (Powers) submenu selected. It displays three columns of power data: Active Powers (P1: 254.3 kW, P2: 254.3 kW, P3: 254.3 kW, P: 763.0 kW), Reactive Powers (Q1: -68.1 kVAR, Q2: -68.1 kVAR, Q3: -68.1 kVAR, Q: -204.4 kVAR), and Apparent Powers (S1: 263.4 kVA, S2: 263.4 kVA, S3: 263.4 kVA, S: 790.4 kVA).</p> | | | | | | | | | | | | | | | | | | | | | | | | | | | |
| <p>Alarm list</p> | <p>Alarm is also one of the most important functions for monitoring and maintaining field devices. Alarms can help users rapidly respond to abnormal phenomenon and prevent some actual malfunction.</p> <p>From the “Alarm list” page, the device’s warning/alarm/timing/ trip message etc. will be shown in the list if it is activated.</p> |  <p>The screenshot shows the 'Alarm list' page with the 'Alarm list' submenu selected. It displays a list of alarm descriptions with red warning icons: Trip Coil disconnected, L1 sensor Disconnected, L2 sensor Disconnected, L3 sensor Disconnected, Ne sensor Disconnected, and CB undefined. There are navigation buttons for page 1/1.</p> | | | | | | | | | | | | | | | | | | | | | | | | | | | |
| <p>History Data</p> | <p>“History Data” provides three types of the data, including “Event Log”, “Trip History” and “Measurement History”.</p> <p>Click the “History Data” menu, it will popup the window for selection. Click related button, it will switch to related data page.</p> <p>Event log</p> <p>The event log can monitor and show events for each connected device. It can record different types of information such as application errors, breaker related control events, some trip/timing/alarm history.</p> <p>From the “Event log” page, the latest but no more than 250 event logs from the device will be shown in the list.</p> |  <p>The top part of the screenshot shows three buttons: Event Log, Trip History, and Measure History.</p> <p>The bottom part shows the 'History Data' page with the 'History Data' submenu selected. It displays a table of event logs:</p> <table border="1"> <thead> <tr> <th>NO.</th> <th>Time</th> <th>Event Description</th> </tr> </thead> <tbody> <tr> <td>1</td> <td>1971-03-19 22:17:20</td> <td>L prealarm on</td> </tr> <tr> <td>2</td> <td>1971-03-19 22:17:20</td> <td>CB Close</td> </tr> <tr> <td>3</td> <td>1971-03-19 22:17:20</td> <td>Supply from Vaux on</td> </tr> <tr> <td>4</td> <td>1971-03-19 22:17:17</td> <td>L prealarm off</td> </tr> <tr> <td>5</td> <td>1971-03-19 22:17:17</td> <td>CB Open</td> </tr> <tr> <td>6</td> <td>1971-03-19 22:17:17</td> <td>Supply from Vaux off</td> </tr> <tr> <td>7</td> <td>1971-03-17 04:26:14</td> <td>L prealarm on</td> </tr> <tr> <td>8</td> <td>1971-03-17 04:26:14</td> <td>CB Close</td> </tr> </tbody> </table> | NO. | Time | Event Description | 1 | 1971-03-19 22:17:20 | L prealarm on | 2 | 1971-03-19 22:17:20 | CB Close | 3 | 1971-03-19 22:17:20 | Supply from Vaux on | 4 | 1971-03-19 22:17:17 | L prealarm off | 5 | 1971-03-19 22:17:17 | CB Open | 6 | 1971-03-19 22:17:17 | Supply from Vaux off | 7 | 1971-03-17 04:26:14 | L prealarm on | 8 | 1971-03-17 04:26:14 | CB Close |
| NO. | Time | Event Description | | | | | | | | | | | | | | | | | | | | | | | | | | | |
| 1 | 1971-03-19 22:17:20 | L prealarm on | | | | | | | | | | | | | | | | | | | | | | | | | | | |
| 2 | 1971-03-19 22:17:20 | CB Close | | | | | | | | | | | | | | | | | | | | | | | | | | | |
| 3 | 1971-03-19 22:17:20 | Supply from Vaux on | | | | | | | | | | | | | | | | | | | | | | | | | | | |
| 4 | 1971-03-19 22:17:17 | L prealarm off | | | | | | | | | | | | | | | | | | | | | | | | | | | |
| 5 | 1971-03-19 22:17:17 | CB Open | | | | | | | | | | | | | | | | | | | | | | | | | | | |
| 6 | 1971-03-19 22:17:17 | Supply from Vaux off | | | | | | | | | | | | | | | | | | | | | | | | | | | |
| 7 | 1971-03-17 04:26:14 | L prealarm on | | | | | | | | | | | | | | | | | | | | | | | | | | | |
| 8 | 1971-03-17 04:26:14 | CB Close | | | | | | | | | | | | | | | | | | | | | | | | | | | |

| Device page | Description | Picture |
|--------------------------------|--|---|
| <p>History Data</p> | <p>Trip History</p> <p>The “Trip History” recorded the trip information like trip type, trip time, trip current and trip data.</p> <p>The latest but no more than 30 items of trip records from the device will be shown in the list.</p> |  |
| | <p>Measure History</p> <p>The “Measure History” recorded the last 24 time intervals measurement over a settable period of time. It records measurement data such as: average power, maximum power, maximum and minimum current, maximum and minimum voltage.</p> |  |
| <p>Network Analyzer</p> | <p>“Network Analyzer” will monitor the quality of energy in terms of harmonics, micro-interruptions or voltage dips.</p> <p>“Network Analyzer” can be shown if this function is supported and enabled in the device.</p> <p>Notes: The “Manual/Automatic” update function for harmonics can be selected if the device is work at “Remote” mode.</p> |  |

i *Notes: Some data show blank in “General view”, “Information” or “Measurements” pages may because of the device does not support related function.*

4.5.2 Device pages matrix

Different types of devices support different functions in the Lite Panel. Therefore, depending on the device different information is shown on each page. For example, compare to the meters, the breakers will have alarm list page. For each type of device's page, please check Table 9.

Table 9 Device pages matrix





| Device type | General view | Information | Measurements | Alarm list | History Data | Network Analyzer |
|----------------|--------------|-------------|--------------|------------|--------------|------------------|
| Emax 2 | √ | √ | √ | √ | √ | √[1] |
| Ekip UP | √ | √ | √ | √ | √ | √ |
| Tmax XT | √ | √ | √ | √ | √[2] | √[1] |
| TruOne ATS | √ | √ | √ | √ | √[3] | |
| M2M | √ | √ | √ | | | |
| DMTME | √ | √ | √ | | | |
| CMS 700 | √ | √ | √ | | | |
| Fuse Gear ITS2 | √ | √ | √ | √ | | |
| IM300 | √ | √ | √ | | | |
| EQmeters | √ | √ | √ | | | |
| M4M | √ | √ | √ | | | |
| M1M/ M1M C | √ | √ | √ | | | |
| CM-TCN.012 | √ | √ | √ | | | |
| SCU100 | √ | √ | √ | | | |
| Emax 3 | √ | √ | √ | √ | √ | √ |

-  **Notes:**[1] Only Ekip G-Hi Touch and Ekip Hi Touch supports Network analyzer functions.
 [2] Only Tmax XT (Touch/ Hi Touch) supports history data functions.
 [3] TruOne ATS supports only history data (event log) function.
 [4] SCU100 supports only sensors as in CMS700. (No I/O modules or meters are supported).

4.5.3 Device remote control

For circuit-breakers, fuse gear and switches can be remote controlled by users with the appropriate access. For user’s access, please refer to 4.1.1.

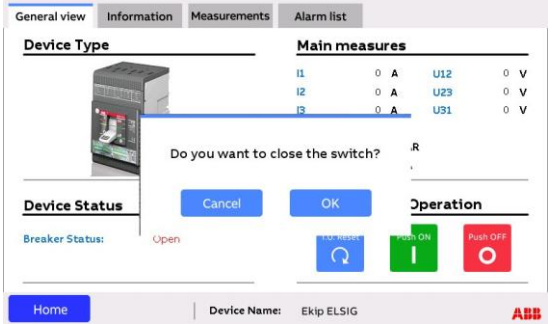
To remote control the breaker or switch, the breaker or switch should be worked at remote mode, not the local mode. Users can view the device’s “Information” page and check the operating mode status.

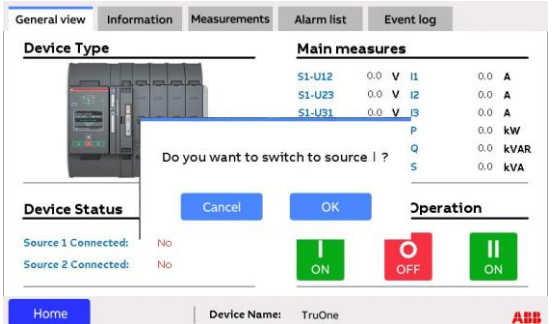
| Description | Picture |
|--|---|
| <p>To avoid a possible malfunction on the breaker, the message “Do you want to open the switch?” will pop up to confirm the selection when the Push OFF  button is pushed.</p> <p>To avoid a possible malfunction on the breaker, the message “Do you want to close the switch?” will pop up to confirm the selection when the Push ON  button is pushed.</p> |  |
| <p>To avoid a possible malfunction on the switch, the message “Do you want to switch to source I ?” will pop up to confirm the selection when the Push ON  button is pushed.</p> <p>To avoid a possible malfunction on the switch, the message “Do you want to switch to source II ?” will pop up to confirm the selection when the Push ON  button is pushed.</p> |  |

! IMPORTANT: The remote control of any device should only be performed by properly trained personally. ABB accepts no liability for damage to property or personal injury due to failure to comply with the instructions contained in this document.

4.5.4 Real time alarm

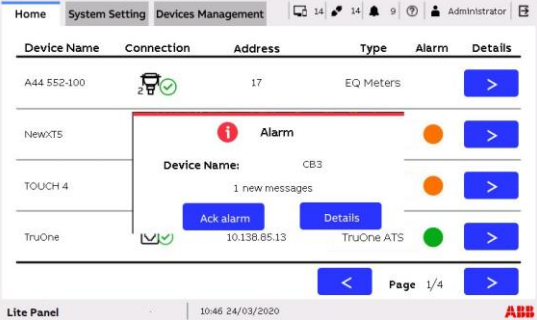
| Description | Picture |
|---|--|
| <p>Any time there is new alarm or warning active on devices, the new message will be displayed on the screen of the Lite Panel.</p> <p>The popup alarm window will display the alarm device name and number of new messages.</p> <p>Ack alarm button to ack alarm on the Lite Panel. The popup window will be closed and sound will be off.</p> <p>Details button to access the alarm device's alarm list page.</p> <p>As default, the Lite Panel will not sound an alarm on each new message.</p> <p>Two ways to silence the alarm:</p> <ol style="list-style-type: none"> ① Click the "Ack alarm" button ② Refer to section 4.3, set "Alarm sound on/off" to off. |  <p>The screenshot shows the 'Devices Management' page in the Lite Panel. A table lists devices with columns for Device Name, Connection, Address, Type, Alarm, and Details. An 'Alarm' popup window is overlaid on the table, showing 'Device Name: CB3' and '1 new messages'. The popup contains 'Ack alarm' and 'Details' buttons. The bottom of the screen shows 'Lite Panel' and the date '10:46 24/03/2020'.</p> |

i Notes: Ack alarm will only acknowledge the alarm on the Lite Panel but not on the field device.

5. FIRMWARE UPGRADE

Customers can write a mail to global-el.operations.digital@abb.com support center to ask for new firmware if encounter following situations:

- ① Lite Panel malfunction or software bugs
- ② Customers have new function requirement



The support center will help and guide the customer to upgrade the Lite Panel firmware.















6. TROUBLESHOOTING

| Issue | Possible Solution |
|---|--|
| Modbus TCP device cannot be scanned in Lite Panel | Check that Lite Panel's IP address has been set. Please refer 4.3 about IP setting. |
| | Check that Modbus TCP devices' IP address are in the same LAN with Lite Panel's IP. |
| | Check that the Modbus TCP device's IP range is inputted correct in device management page. |
| Modbus RTU device cannot be scanned in Lite Panel | Check that the parameters are inputted correct in device management page. |
| | Check the Lite Panel wiring integrity, the data+ /data- are wiring to correct pin. |
| | Check that the wiring of the missing devices is correct. |
| | Check that two devices do not have the same slave address in each COM port. |
| Check that the missing device's communication setting (Baudrate, parity). | Lite Panel cannot startup |
| Check that the power is wiring well. | |
| COM LED on Lite Panel no flash | Check if the Modbus TCP and Modbus RTU devices are communication well from Lite Panel Home page. |
| User login fail | Check the selected user and password consistency |



7. ANNEX

Compatible device preview

| Device type | General view | | | | | | | | | | | | | | | | | | | | | | | | | | | | | | | | | | | | |
|---|---|------|-------|--------|----|--------|---|-----|-------|---|----|--------|---|-----|-------|---|----|--------|---|---|-------|----|--|--|--|---|--------|------|--|--|--|---|-------|-----|--|--|--|
| <p>Emax 2</p> | <div style="border: 1px solid #ccc; padding: 5px;"> <div style="display: flex; justify-content: space-between; border-bottom: 1px solid #ccc; margin-bottom: 5px;"> General view Information Measurements Alarm list History Data </div> <div style="display: flex;"> <div style="flex: 1;"> <p>Device Type</p>  </div> <div style="flex: 1;"> <p>Main measures</p> <table border="1"> <tr><td>U12</td><td>0.0</td><td>V</td><td>I1</td><td>620.8</td><td>A</td></tr> <tr><td>U23</td><td>0.0</td><td>V</td><td>I2</td><td>607.8</td><td>A</td></tr> <tr><td>U31</td><td>0.0</td><td>V</td><td>I3</td><td>0.0</td><td>A</td></tr> <tr><td>P</td><td>0.0</td><td colspan="4">kW</td></tr> <tr><td>Q</td><td>0.0</td><td colspan="4">kVAR</td></tr> <tr><td>S</td><td>0.0</td><td colspan="4">kVA</td></tr> </table> </div> </div> <div style="display: flex; margin-top: 10px;"> <div style="flex: 1;"> <p>Device Status</p> <p>Breaker Status: Closed</p> <p>Ready to Close Status: Not Ready to close</p> </div> <div style="flex: 1;"> <p>Device Remote Operation</p> <div style="display: flex; justify-content: space-around;"> <div style="border: 1px solid #ccc; padding: 5px; background-color: #4a90e2; color: white; text-align: center; width: 40px;">T.U. Reset</div> <div style="border: 1px solid #ccc; padding: 5px; background-color: #27ae60; color: white; text-align: center; width: 40px;">Push ON</div> <div style="border: 1px solid #ccc; padding: 5px; background-color: #e91e63; color: white; text-align: center; width: 40px;">Push OFF</div> </div> </div> </div> <div style="display: flex; justify-content: space-between; margin-top: 10px; border-top: 1px solid #ccc;"> <div style="background-color: #4a90e2; color: white; padding: 5px 10px; border-radius: 3px;">Home</div> <div>Device Name: TOH3</div> <div style="color: red; font-weight: bold; font-size: 1.2em;">ABB</div> </div> </div> | U12 | 0.0 | V | I1 | 620.8 | A | U23 | 0.0 | V | I2 | 607.8 | A | U31 | 0.0 | V | I3 | 0.0 | A | P | 0.0 | kW | | | | Q | 0.0 | kVAR | | | | S | 0.0 | kVA | | | |
| U12 | 0.0 | V | I1 | 620.8 | A | | | | | | | | | | | | | | | | | | | | | | | | | | | | | | | | |
| U23 | 0.0 | V | I2 | 607.8 | A | | | | | | | | | | | | | | | | | | | | | | | | | | | | | | | | |
| U31 | 0.0 | V | I3 | 0.0 | A | | | | | | | | | | | | | | | | | | | | | | | | | | | | | | | | |
| P | 0.0 | kW | | | | | | | | | | | | | | | | | | | | | | | | | | | | | | | | | | | |
| Q | 0.0 | kVAR | | | | | | | | | | | | | | | | | | | | | | | | | | | | | | | | | | | |
| S | 0.0 | kVA | | | | | | | | | | | | | | | | | | | | | | | | | | | | | | | | | | | |
| <p>Tmax XT (XT2-XT4-XT5-XT7)</p> | <div style="border: 1px solid #ccc; padding: 5px;"> <div style="display: flex; justify-content: space-between; border-bottom: 1px solid #ccc; margin-bottom: 5px;"> General view Information Measurements Alarm list History Data NetworkAnalyzer </div> <div style="display: flex;"> <div style="flex: 1;"> <p>Device Type</p>  </div> <div style="flex: 1;"> <p>Main measures</p> <table border="1"> <tr><td>U12</td><td>0.0</td><td>V</td><td>I1</td><td>0.0</td><td>A</td></tr> <tr><td>U23</td><td>0.0</td><td>V</td><td>I2</td><td>0.0</td><td>A</td></tr> <tr><td>U31</td><td>0.0</td><td>V</td><td>I3</td><td>0.0</td><td>A</td></tr> <tr><td>P</td><td></td><td colspan="4">kW</td></tr> <tr><td>Q</td><td></td><td colspan="4">kVAR</td></tr> <tr><td>S</td><td></td><td colspan="4">kVA</td></tr> </table> </div> </div> <div style="display: flex; margin-top: 10px;"> <div style="flex: 1;"> <p>Device Status</p> <p>Breaker Status: Closed</p> <p>Ready to Close Status: Not Ready to close</p> </div> <div style="flex: 1;"> <p>Device Remote Operation</p> <div style="display: flex; justify-content: space-around;"> <div style="border: 1px solid #ccc; padding: 5px; background-color: #4a90e2; color: white; text-align: center; width: 40px;">T.U. Reset</div> <div style="border: 1px solid #ccc; padding: 5px; background-color: #27ae60; color: white; text-align: center; width: 40px;">Push ON</div> <div style="border: 1px solid #ccc; padding: 5px; background-color: #e91e63; color: white; text-align: center; width: 40px;">Push OFF</div> </div> </div> </div> <div style="display: flex; justify-content: space-between; margin-top: 10px; border-top: 1px solid #ccc;"> <div style="background-color: #4a90e2; color: white; padding: 5px 10px; border-radius: 3px;">Home</div> <div>Device Name: CB TagName</div> <div style="color: red; font-weight: bold; font-size: 1.2em;">ABB</div> </div> </div> | U12 | 0.0 | V | I1 | 0.0 | A | U23 | 0.0 | V | I2 | 0.0 | A | U31 | 0.0 | V | I3 | 0.0 | A | P | | kW | | | | Q | | kVAR | | | | S | | kVA | | | |
| U12 | 0.0 | V | I1 | 0.0 | A | | | | | | | | | | | | | | | | | | | | | | | | | | | | | | | | |
| U23 | 0.0 | V | I2 | 0.0 | A | | | | | | | | | | | | | | | | | | | | | | | | | | | | | | | | |
| U31 | 0.0 | V | I3 | 0.0 | A | | | | | | | | | | | | | | | | | | | | | | | | | | | | | | | | |
| P | | kW | | | | | | | | | | | | | | | | | | | | | | | | | | | | | | | | | | | |
| Q | | kVAR | | | | | | | | | | | | | | | | | | | | | | | | | | | | | | | | | | | |
| S | | kVA | | | | | | | | | | | | | | | | | | | | | | | | | | | | | | | | | | | |
| <p>Ekip UP</p> | <div style="border: 1px solid #ccc; padding: 5px;"> <div style="display: flex; justify-content: space-between; border-bottom: 1px solid #ccc; margin-bottom: 5px;"> General view Information Measurements Alarm list History Data </div> <div style="display: flex;"> <div style="flex: 1;"> <p>Device Type</p>  </div> <div style="flex: 1;"> <p>Main measures</p> <table border="1"> <tr><td>U12</td><td>380.3</td><td>V</td><td>I1</td><td>1200.0</td><td>A</td></tr> <tr><td>U23</td><td>380.3</td><td>V</td><td>I2</td><td>1200.0</td><td>A</td></tr> <tr><td>U31</td><td>380.3</td><td>V</td><td>I3</td><td>1200.0</td><td>A</td></tr> <tr><td>P</td><td>763.0</td><td colspan="4">kW</td></tr> <tr><td>Q</td><td>-204.4</td><td colspan="4">kVAR</td></tr> <tr><td>S</td><td>790.4</td><td colspan="4">kVA</td></tr> </table> </div> </div> <div style="display: flex; margin-top: 10px;"> <div style="flex: 1;"> <p>Device Status</p> <p>Breaker Status: Closed</p> <p>Ready to Close Status: Not Ready to close</p> </div> <div style="flex: 1;"> <p>Device Remote Operation</p> <div style="display: flex; justify-content: space-around;"> <div style="border: 1px solid #ccc; padding: 5px; background-color: #ccc; text-align: center; width: 40px;">T.U. Reset</div> <div style="border: 1px solid #ccc; padding: 5px; background-color: #ccc; text-align: center; width: 40px;">Push ON</div> <div style="border: 1px solid #ccc; padding: 5px; background-color: #ccc; text-align: center; width: 40px;">Push OFF</div> </div> </div> </div> <div style="display: flex; justify-content: space-between; margin-top: 10px; border-top: 1px solid #ccc;"> <div style="background-color: #4a90e2; color: white; padding: 5px 10px; border-radius: 3px;">Home</div> <div>Device Name: Eswitch</div> <div style="color: red; font-weight: bold; font-size: 1.2em;">ABB</div> </div> </div> | U12 | 380.3 | V | I1 | 1200.0 | A | U23 | 380.3 | V | I2 | 1200.0 | A | U31 | 380.3 | V | I3 | 1200.0 | A | P | 763.0 | kW | | | | Q | -204.4 | kVAR | | | | S | 790.4 | kVA | | | |
| U12 | 380.3 | V | I1 | 1200.0 | A | | | | | | | | | | | | | | | | | | | | | | | | | | | | | | | | |
| U23 | 380.3 | V | I2 | 1200.0 | A | | | | | | | | | | | | | | | | | | | | | | | | | | | | | | | | |
| U31 | 380.3 | V | I3 | 1200.0 | A | | | | | | | | | | | | | | | | | | | | | | | | | | | | | | | | |
| P | 763.0 | kW | | | | | | | | | | | | | | | | | | | | | | | | | | | | | | | | | | | |
| Q | -204.4 | kVAR | | | | | | | | | | | | | | | | | | | | | | | | | | | | | | | | | | | |
| S | 790.4 | kVA | | | | | | | | | | | | | | | | | | | | | | | | | | | | | | | | | | | |

| Device type | General view | | | | | | | | | | | | | | | | | | | | | | | | |
|-----------------|---|--------|------------|-----|---------|--------|---------|-----|---------|--------|---------|-----|---------|--------|--------|---|----------|--------|----------|---|------------|--------|---------|---|-----------|
| Fuse Gear ITS2 | <div data-bbox="643 185 1469 622"> <p>General view Information Measurements Alarm list</p> <p>Device Type</p>  <p>Main measures</p> <table border="1"> <tr><td>U1</td><td>158 V</td><td>I1</td><td>471.2 A</td></tr> <tr><td>U2</td><td>159 V</td><td>I2</td><td>522.5 A</td></tr> <tr><td>U3</td><td>160 V</td><td>I3</td><td>329.0 A</td></tr> <tr><td>U12</td><td>274 V</td><td>P</td><td>100.4 kW</td></tr> <tr><td>U23</td><td>275 V</td><td>Q</td><td>184.3 kVAR</td></tr> <tr><td>U31</td><td>276 V</td><td>S</td><td>209.9 kVA</td></tr> </table> <p>Device Status</p> <p>Breaker Status: Closed</p> <p>Device Remote Operation</p> <p>Push ON  Push OFF </p> </div> <div data-bbox="643 629 1469 678"> <p>Home Device Name: TAG.Name.. </p> </div> | U1 | 158 V | I1 | 471.2 A | U2 | 159 V | I2 | 522.5 A | U3 | 160 V | I3 | 329.0 A | U12 | 274 V | P | 100.4 kW | U23 | 275 V | Q | 184.3 kVAR | U31 | 276 V | S | 209.9 kVA |
| U1 | 158 V | I1 | 471.2 A | | | | | | | | | | | | | | | | | | | | | | |
| U2 | 159 V | I2 | 522.5 A | | | | | | | | | | | | | | | | | | | | | | |
| U3 | 160 V | I3 | 329.0 A | | | | | | | | | | | | | | | | | | | | | | |
| U12 | 274 V | P | 100.4 kW | | | | | | | | | | | | | | | | | | | | | | |
| U23 | 275 V | Q | 184.3 kVAR | | | | | | | | | | | | | | | | | | | | | | |
| U31 | 276 V | S | 209.9 kVA | | | | | | | | | | | | | | | | | | | | | | |
| Tmax XT(XT1...) | <div data-bbox="643 719 1469 1155"> <p>General view Information Measurements Alarm list</p> <p>Device Type</p>  <p>Main measures</p> <table border="1"> <tr><td>I1</td><td>0 A</td><td>U12</td><td>0 V</td></tr> <tr><td>I2</td><td>0 A</td><td>U23</td><td>0 V</td></tr> <tr><td>I3</td><td>0 A</td><td>U31</td><td>0 V</td></tr> <tr><td>P</td><td>0.0 kW</td><td></td><td></td></tr> <tr><td>Q</td><td>0.0 kVAR</td><td></td><td></td></tr> <tr><td>S</td><td>0.0 kVA</td><td></td><td></td></tr> </table> <p>Device Status</p> <p>Breaker Status: Closed</p> <p>Device Remote Operation</p> <p>T.U. Reset  Push ON  Push OFF </p> </div> <div data-bbox="643 1167 1469 1216"> <p>Home Device Name: OldXT2 </p> </div> | I1 | 0 A | U12 | 0 V | I2 | 0 A | U23 | 0 V | I3 | 0 A | U31 | 0 V | P | 0.0 kW | | | Q | 0.0 kVAR | | | S | 0.0 kVA | | |
| I1 | 0 A | U12 | 0 V | | | | | | | | | | | | | | | | | | | | | | |
| I2 | 0 A | U23 | 0 V | | | | | | | | | | | | | | | | | | | | | | |
| I3 | 0 A | U31 | 0 V | | | | | | | | | | | | | | | | | | | | | | |
| P | 0.0 kW | | | | | | | | | | | | | | | | | | | | | | | | |
| Q | 0.0 kVAR | | | | | | | | | | | | | | | | | | | | | | | | |
| S | 0.0 kVA | | | | | | | | | | | | | | | | | | | | | | | | |
| TruOne ATS | <div data-bbox="643 1263 1469 1700"> <p>General view Information Measurements Alarm list Event log</p> <p>Device Type</p>  <p>Main measures</p> <table border="1"> <tr><td>S1-U12</td><td>385.6 V</td><td>I1</td><td>0.0 A</td></tr> <tr><td>S1-U23</td><td>385.9 V</td><td>I2</td><td>0.0 A</td></tr> <tr><td>S1-U31</td><td>385.0 V</td><td>I3</td><td>0.0 A</td></tr> <tr><td>S2-U12</td><td>0.0 V</td><td>P</td><td>0.0 kW</td></tr> <tr><td>S2-U23</td><td>0.0 V</td><td>Q</td><td>0.0 kVAR</td></tr> <tr><td>S2-U31</td><td>0.0 V</td><td>S</td><td>0.0 kVA</td></tr> </table> <p>Device Status</p> <p>Source 1 Connected: Switch in position I</p> <p>Source 2 Connected: No</p> <p>Device Remote Operation</p> <p>  </p> </div> <div data-bbox="643 1711 1469 1760"> <p>Home Device Name: Tag Name </p> </div> | S1-U12 | 385.6 V | I1 | 0.0 A | S1-U23 | 385.9 V | I2 | 0.0 A | S1-U31 | 385.0 V | I3 | 0.0 A | S2-U12 | 0.0 V | P | 0.0 kW | S2-U23 | 0.0 V | Q | 0.0 kVAR | S2-U31 | 0.0 V | S | 0.0 kVA |
| S1-U12 | 385.6 V | I1 | 0.0 A | | | | | | | | | | | | | | | | | | | | | | |
| S1-U23 | 385.9 V | I2 | 0.0 A | | | | | | | | | | | | | | | | | | | | | | |
| S1-U31 | 385.0 V | I3 | 0.0 A | | | | | | | | | | | | | | | | | | | | | | |
| S2-U12 | 0.0 V | P | 0.0 kW | | | | | | | | | | | | | | | | | | | | | | |
| S2-U23 | 0.0 V | Q | 0.0 kVAR | | | | | | | | | | | | | | | | | | | | | | |
| S2-U31 | 0.0 V | S | 0.0 kVA | | | | | | | | | | | | | | | | | | | | | | |

| Device type | General view | | | | | | | | | | | | | | | | | | | | | | | | | | | | | | | | | | | | | | | | | | |
|-------------|--|-----|-----|------|-----|-------|---|-----|-------|---|----|------|-----|-----|-------|----|----|------|---|----|------|---|----|------|-----|----|------|---|----|------|-----|----|------|---|----|------|-----|---|------|---|---|------|-----|
| M2M | <div data-bbox="662 190 1484 235"> General view Information Measurements </div> <div data-bbox="678 241 1037 280"> Device Type </div> <div data-bbox="766 286 941 459"> </div> <div data-bbox="1093 241 1460 280"> Main measures </div> <div data-bbox="1093 286 1460 459"> <table border="0"> <tr><td>U3F</td><td>0</td><td>V</td></tr> <tr><td>I3F</td><td>0.000</td><td>A</td></tr> <tr><td>P</td><td>0</td><td>W</td></tr> <tr><td>Q</td><td>0</td><td>VAR</td></tr> <tr><td>S</td><td>0</td><td>VA</td></tr> </table> </div> <div data-bbox="662 638 1484 683"> Home Device Name: M2M_COM2_31 ABB </div> | U3F | 0 | V | I3F | 0.000 | A | P | 0 | W | Q | 0 | VAR | S | 0 | VA | | | | | | | | | | | | | | | | | | | | | | | | | | | |
| U3F | 0 | V | | | | | | | | | | | | | | | | | | | | | | | | | | | | | | | | | | | | | | | | | |
| I3F | 0.000 | A | | | | | | | | | | | | | | | | | | | | | | | | | | | | | | | | | | | | | | | | | |
| P | 0 | W | | | | | | | | | | | | | | | | | | | | | | | | | | | | | | | | | | | | | | | | | |
| Q | 0 | VAR | | | | | | | | | | | | | | | | | | | | | | | | | | | | | | | | | | | | | | | | | |
| S | 0 | VA | | | | | | | | | | | | | | | | | | | | | | | | | | | | | | | | | | | | | | | | | |
| DMTME | <div data-bbox="662 728 1484 772"> General view Information Measurements </div> <div data-bbox="678 779 1037 817"> Device Type </div> <div data-bbox="758 824 949 1008"> </div> <div data-bbox="1093 779 1460 817"> Main measures </div> <div data-bbox="1093 824 1460 1008"> <table border="0"> <tr><td>U3F</td><td>0</td><td>V</td></tr> <tr><td>I3F</td><td>0.000</td><td>A</td></tr> <tr><td>P</td><td>0</td><td>W</td></tr> <tr><td>Q</td><td>0</td><td>VAR</td></tr> <tr><td>S</td><td>0</td><td>VA</td></tr> </table> </div> <div data-bbox="662 1176 1484 1220"> Home Device Name: DMTME_COM2_33 ABB </div> | U3F | 0 | V | I3F | 0.000 | A | P | 0 | W | Q | 0 | VAR | S | 0 | VA | | | | | | | | | | | | | | | | | | | | | | | | | | | |
| U3F | 0 | V | | | | | | | | | | | | | | | | | | | | | | | | | | | | | | | | | | | | | | | | | |
| I3F | 0.000 | A | | | | | | | | | | | | | | | | | | | | | | | | | | | | | | | | | | | | | | | | | |
| P | 0 | W | | | | | | | | | | | | | | | | | | | | | | | | | | | | | | | | | | | | | | | | | |
| Q | 0 | VAR | | | | | | | | | | | | | | | | | | | | | | | | | | | | | | | | | | | | | | | | | |
| S | 0 | VA | | | | | | | | | | | | | | | | | | | | | | | | | | | | | | | | | | | | | | | | | |
| EQmeter | <div data-bbox="662 1265 1484 1310"> General view Information Measurements </div> <div data-bbox="678 1317 1037 1355"> Device Type </div> <div data-bbox="694 1366 1013 1612"> </div> <div data-bbox="1093 1317 1460 1355"> Main measures </div> <div data-bbox="1093 1361 1460 1612"> <table border="0"> <tr><td>U12</td><td>0.4</td><td>V</td><td>I1</td><td>0.00</td><td>A</td></tr> <tr><td>U23</td><td>215.1</td><td>V</td><td>I2</td><td>0.00</td><td>A</td></tr> <tr><td>U31</td><td>214.4</td><td>V</td><td>I3</td><td>0.00</td><td>A</td></tr> <tr><td>P1</td><td>0.00</td><td>W</td><td>Q1</td><td>0.00</td><td>VAR</td></tr> <tr><td>P2</td><td>0.00</td><td>W</td><td>Q2</td><td>0.00</td><td>VAR</td></tr> <tr><td>P3</td><td>0.00</td><td>W</td><td>Q3</td><td>0.00</td><td>VAR</td></tr> <tr><td>P</td><td>0.00</td><td>W</td><td>Q</td><td>0.00</td><td>VAR</td></tr> </table> </div> <div data-bbox="662 1713 1484 1758"> Home Device Name: A44 552-100 ABB </div> | U12 | 0.4 | V | I1 | 0.00 | A | U23 | 215.1 | V | I2 | 0.00 | A | U31 | 214.4 | V | I3 | 0.00 | A | P1 | 0.00 | W | Q1 | 0.00 | VAR | P2 | 0.00 | W | Q2 | 0.00 | VAR | P3 | 0.00 | W | Q3 | 0.00 | VAR | P | 0.00 | W | Q | 0.00 | VAR |
| U12 | 0.4 | V | I1 | 0.00 | A | | | | | | | | | | | | | | | | | | | | | | | | | | | | | | | | | | | | | | |
| U23 | 215.1 | V | I2 | 0.00 | A | | | | | | | | | | | | | | | | | | | | | | | | | | | | | | | | | | | | | | |
| U31 | 214.4 | V | I3 | 0.00 | A | | | | | | | | | | | | | | | | | | | | | | | | | | | | | | | | | | | | | | |
| P1 | 0.00 | W | Q1 | 0.00 | VAR | | | | | | | | | | | | | | | | | | | | | | | | | | | | | | | | | | | | | | |
| P2 | 0.00 | W | Q2 | 0.00 | VAR | | | | | | | | | | | | | | | | | | | | | | | | | | | | | | | | | | | | | | |
| P3 | 0.00 | W | Q3 | 0.00 | VAR | | | | | | | | | | | | | | | | | | | | | | | | | | | | | | | | | | | | | | |
| P | 0.00 | W | Q | 0.00 | VAR | | | | | | | | | | | | | | | | | | | | | | | | | | | | | | | | | | | | | | |

| Device type | General view | | | | | | | | | | | | | | | | | | | | | | | | | | | | | | | | | | | | | | | | | | |
|-------------|---|-----|--------|---------|-----|------|---|-----|-------|---|----|------|---|-----|-------|---|----|------|---|----|--------|---|----|--------|-----|----|--------|---|----|--------|-----|----|--------|---|----|--------|-----|---|---------|---|---|---------|-----|
| M4M | <div data-bbox="635 188 1449 230"> General view Information Measurements </div> <div data-bbox="655 241 1007 273"> Device Type </div> <div data-bbox="703 286 959 539">  </div> <div data-bbox="1066 241 1422 273"> Main measures </div> <div data-bbox="1066 286 1422 539"> <table border="1"> <tbody> <tr> <td>U12</td> <td>411.3</td> <td>V</td> <td>I1</td> <td>2.54</td> <td>A</td> </tr> <tr> <td>U23</td> <td>409.3</td> <td>V</td> <td>I2</td> <td>3.37</td> <td>A</td> </tr> <tr> <td>U31</td> <td>409.3</td> <td>V</td> <td>I3</td> <td>4.22</td> <td>A</td> </tr> <tr> <td>P1</td> <td>541.08</td> <td>W</td> <td>Q1</td> <td>306.37</td> <td>VAR</td> </tr> <tr> <td>P2</td> <td>716.51</td> <td>W</td> <td>Q2</td> <td>408.30</td> <td>VAR</td> </tr> <tr> <td>P3</td> <td>889.55</td> <td>W</td> <td>Q3</td> <td>511.81</td> <td>VAR</td> </tr> <tr> <td>P</td> <td>2147.14</td> <td>W</td> <td>Q</td> <td>1226.48</td> <td>VAR</td> </tr> </tbody> </table> </div> <div data-bbox="635 629 1449 674"> Home Device Name: M4M 30 ETHERNET ABB </div> | U12 | 411.3 | V | I1 | 2.54 | A | U23 | 409.3 | V | I2 | 3.37 | A | U31 | 409.3 | V | I3 | 4.22 | A | P1 | 541.08 | W | Q1 | 306.37 | VAR | P2 | 716.51 | W | Q2 | 408.30 | VAR | P3 | 889.55 | W | Q3 | 511.81 | VAR | P | 2147.14 | W | Q | 1226.48 | VAR |
| U12 | 411.3 | V | I1 | 2.54 | A | | | | | | | | | | | | | | | | | | | | | | | | | | | | | | | | | | | | | | |
| U23 | 409.3 | V | I2 | 3.37 | A | | | | | | | | | | | | | | | | | | | | | | | | | | | | | | | | | | | | | | |
| U31 | 409.3 | V | I3 | 4.22 | A | | | | | | | | | | | | | | | | | | | | | | | | | | | | | | | | | | | | | | |
| P1 | 541.08 | W | Q1 | 306.37 | VAR | | | | | | | | | | | | | | | | | | | | | | | | | | | | | | | | | | | | | | |
| P2 | 716.51 | W | Q2 | 408.30 | VAR | | | | | | | | | | | | | | | | | | | | | | | | | | | | | | | | | | | | | | |
| P3 | 889.55 | W | Q3 | 511.81 | VAR | | | | | | | | | | | | | | | | | | | | | | | | | | | | | | | | | | | | | | |
| P | 2147.14 | W | Q | 1226.48 | VAR | | | | | | | | | | | | | | | | | | | | | | | | | | | | | | | | | | | | | | |
| CMS700 | <div data-bbox="635 725 1449 768"> General view Information Measurements </div> <div data-bbox="655 779 1007 810"> Device Type </div> <div data-bbox="679 824 1002 1070">  </div> <div data-bbox="1066 779 1422 810"> Main measures </div> <div data-bbox="1066 824 1422 1070"> <table border="1"> <tbody> <tr> <td>U1</td> <td>222.64</td> <td>V</td> <td>I1</td> <td>0.00</td> <td>A</td> </tr> <tr> <td>U2</td> <td>0.06</td> <td>V</td> <td>I2</td> <td>0.00</td> <td>A</td> </tr> <tr> <td>U3</td> <td>0.02</td> <td>V</td> <td>I3</td> <td>0.00</td> <td>A</td> </tr> <tr> <td>P1</td> <td>0</td> <td>W</td> <td>Q1</td> <td>0</td> <td>VAR</td> </tr> <tr> <td>P2</td> <td>0</td> <td>W</td> <td>Q2</td> <td>0</td> <td>VAR</td> </tr> <tr> <td>P3</td> <td>0</td> <td>W</td> <td>Q3</td> <td>0</td> <td>VAR</td> </tr> <tr> <td>P</td> <td>0</td> <td>W</td> <td>Q</td> <td>0</td> <td>VAR</td> </tr> </tbody> </table> </div> <div data-bbox="635 1171 1449 1216"> Home Device Name: CMS700_COM1_200 ABB </div> | U1 | 222.64 | V | I1 | 0.00 | A | U2 | 0.06 | V | I2 | 0.00 | A | U3 | 0.02 | V | I3 | 0.00 | A | P1 | 0 | W | Q1 | 0 | VAR | P2 | 0 | W | Q2 | 0 | VAR | P3 | 0 | W | Q3 | 0 | VAR | P | 0 | W | Q | 0 | VAR |
| U1 | 222.64 | V | I1 | 0.00 | A | | | | | | | | | | | | | | | | | | | | | | | | | | | | | | | | | | | | | | |
| U2 | 0.06 | V | I2 | 0.00 | A | | | | | | | | | | | | | | | | | | | | | | | | | | | | | | | | | | | | | | |
| U3 | 0.02 | V | I3 | 0.00 | A | | | | | | | | | | | | | | | | | | | | | | | | | | | | | | | | | | | | | | |
| P1 | 0 | W | Q1 | 0 | VAR | | | | | | | | | | | | | | | | | | | | | | | | | | | | | | | | | | | | | | |
| P2 | 0 | W | Q2 | 0 | VAR | | | | | | | | | | | | | | | | | | | | | | | | | | | | | | | | | | | | | | |
| P3 | 0 | W | Q3 | 0 | VAR | | | | | | | | | | | | | | | | | | | | | | | | | | | | | | | | | | | | | | |
| P | 0 | W | Q | 0 | VAR | | | | | | | | | | | | | | | | | | | | | | | | | | | | | | | | | | | | | | |
| IM300 | <div data-bbox="635 1267 1449 1310"> General view Information Measurements </div> <div data-bbox="655 1321 1007 1352"> Device Type </div> <div data-bbox="711 1375 951 1592">  </div> <div data-bbox="1066 1321 1422 1352"> Main measures </div> <div data-bbox="1066 1366 1422 1608"> <table border="1"> <tbody> <tr> <td>U12</td> <td>199</td> <td>V</td> <td>I1</td> <td>19</td> <td>A</td> </tr> <tr> <td>U23</td> <td>0</td> <td>V</td> <td>I2</td> <td>39</td> <td>A</td> </tr> <tr> <td>U31</td> <td>199</td> <td>V</td> <td>I3</td> <td>0</td> <td>A</td> </tr> <tr> <td>P1</td> <td>3800</td> <td>W</td> <td>Q1</td> <td>0</td> <td>VAR</td> </tr> <tr> <td>P2</td> <td>0</td> <td>W</td> <td>Q2</td> <td>0</td> <td>VAR</td> </tr> <tr> <td>P3</td> <td>0</td> <td>W</td> <td>Q3</td> <td>0</td> <td>VAR</td> </tr> <tr> <td>P</td> <td>3800</td> <td>W</td> <td>Q</td> <td>0</td> <td>VAR</td> </tr> </tbody> </table> </div> <div data-bbox="635 1713 1449 1758"> Home Device Name: IM302_COM1_50 ABB </div> | U12 | 199 | V | I1 | 19 | A | U23 | 0 | V | I2 | 39 | A | U31 | 199 | V | I3 | 0 | A | P1 | 3800 | W | Q1 | 0 | VAR | P2 | 0 | W | Q2 | 0 | VAR | P3 | 0 | W | Q3 | 0 | VAR | P | 3800 | W | Q | 0 | VAR |
| U12 | 199 | V | I1 | 19 | A | | | | | | | | | | | | | | | | | | | | | | | | | | | | | | | | | | | | | | |
| U23 | 0 | V | I2 | 39 | A | | | | | | | | | | | | | | | | | | | | | | | | | | | | | | | | | | | | | | |
| U31 | 199 | V | I3 | 0 | A | | | | | | | | | | | | | | | | | | | | | | | | | | | | | | | | | | | | | | |
| P1 | 3800 | W | Q1 | 0 | VAR | | | | | | | | | | | | | | | | | | | | | | | | | | | | | | | | | | | | | | |
| P2 | 0 | W | Q2 | 0 | VAR | | | | | | | | | | | | | | | | | | | | | | | | | | | | | | | | | | | | | | |
| P3 | 0 | W | Q3 | 0 | VAR | | | | | | | | | | | | | | | | | | | | | | | | | | | | | | | | | | | | | | |
| P | 3800 | W | Q | 0 | VAR | | | | | | | | | | | | | | | | | | | | | | | | | | | | | | | | | | | | | | |

M1M / M1M C

General view
Information
Measurements

Device Type



Main measures

| | | | | | |
|-----|------|---|----|----|-----|
| U12 | 199 | V | I1 | 19 | A |
| U23 | 0 | V | I2 | 39 | A |
| U31 | 199 | V | I3 | 0 | A |
| P1 | 3800 | W | Q1 | 0 | VAR |
| P2 | 0 | W | Q2 | 0 | VAR |
| P3 | 0 | W | Q3 | 0 | VAR |
| P | 3800 | W | Q | 0 | VAR |

Home
Device Name: M1M 30C LCD
ABB

CM-TCN.012

General view
Information
Measurements

Device Type



Main measures

| | | |
|----------|------|----|
| Channel1 | 25.8 | °C |
| Channel2 | -- | °C |
| Channel3 | -- | °C |
| Relay1 | On | |
| Relay2 | On | |
| Relay3 | Off | |

Home
Device Name: CM-TCN0.12S
ABB

SCU100

General view
Information
Measurements

Device Type



Main measures

| | | | | | |
|----|--------|---|----|------|-----|
| U1 | 222.64 | V | I1 | 0.00 | A |
| U2 | 0.06 | V | I2 | 0.00 | A |
| U3 | 0.02 | V | I3 | 0.00 | A |
| P1 | 0 | W | Q1 | 0 | VAR |
| P2 | 0 | W | Q2 | 0 | VAR |
| P3 | 0 | W | Q3 | 0 | VAR |
| P | 0 | W | Q | 0 | VAR |

Home
Device Name: SCU100_ETH_174
ABB

Emax 3

General view
Information
Measurements
Alarm list
History Data

Device Type



Device Status

Breaker Status: Closed

Ready to Close Status: Not Ready to close

Main measures

| | | | | | |
|-----|-----|------|----|-------|---|
| U12 | 0.0 | V | I1 | 620.8 | A |
| U23 | 0.0 | V | I2 | 607.8 | A |
| U31 | 0.0 | V | I3 | 0.0 | A |
| P | 0.0 | kW | | | |
| Q | 0.0 | kVAR | | | |
| S | 0.0 | kVA | | | |

Device Remote Operation

↺

T.U. Reset

I

Push ON

O

Push OFF

Home

Device Name: TOH3





—
ABB S.p.A.
Via Pescaria, 5
24123 Bergamo - Italy
Tel.: +39 035 395 111
www.abb.com

