

MANUAL

Universal Motor Controller

UMC100.3 ATEX

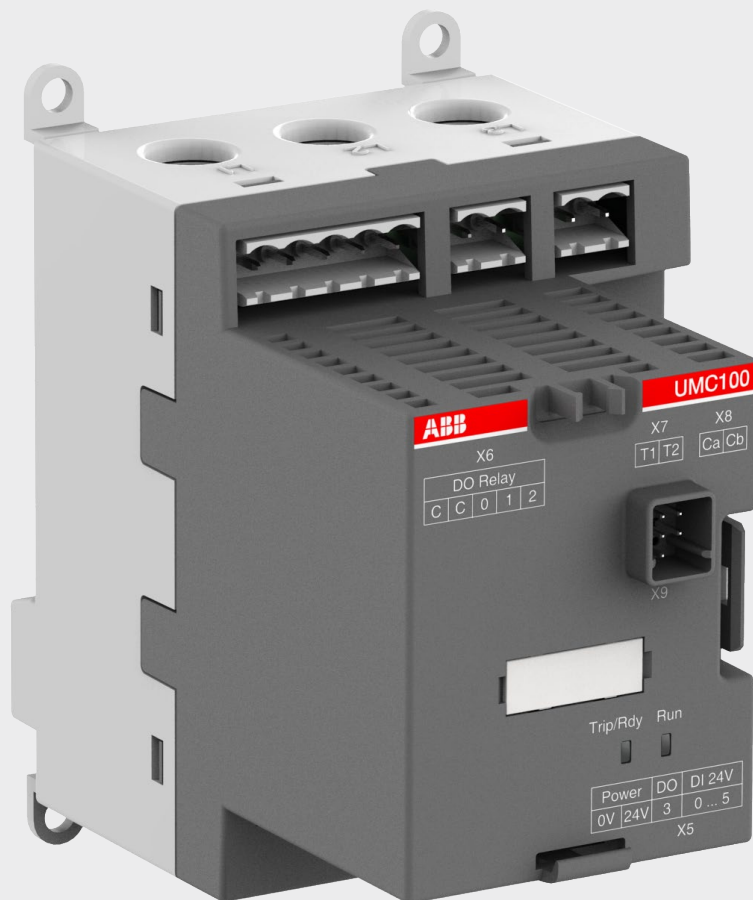

Important notice

Target group

This description is intended for use by trained specialists in electrical installation and control and automation engineering, who are familiar with the applicable national standards.

Safety requirements

The responsible staff must ensure that the application or use of the products described satisfy all the requirements for safety, including all the relevant laws, regulations, guidelines and standards.

Using this Handbook

Symbols

This technical document contains markers to point the reader to important information, potential risks and precautionary information. The following symbols are used:



Symbol to indicate a potentially dangerous situation that can cause damage to the UMC or connected devices or to the environment



Symbol to indicate important information and conditions.



Symbol that indicates a potentially dangerous situation that can cause personal injury

Abbreviations

UMC100.3	Universal Motor Controller; sometimes just called UMC
DCS	Distributed Control System
PLC	Programmable Logic Controller
GSD	Device description file for PROFIBUS networks
EDS	Device description file for DeviceNet and EtherNet/IP™ networks
FDI	Field Device Integration; standard for configuration of field devices
NC / NO	Normally closed / Normally open
FBP	FieldBusPlug is the name for a group of products which allows to connect ABB low voltage control products to different fieldbusses
CI	Communication Interface e.g. PDP32.0 for PROFIBUS

Related Documents

Technical Documentation	Document No.
FIM UMC Edition manual	2CDC135069M0201
Manual of the Custom Application Editor	2CDC135034D0201

Table of contents

7	How to get started
8	New features in comparison to preceeding versions
9	1 System Overview
9	Function Overview
10	Compatibility to previous versions of UMC100.3
11	Description of Components
19	2 Installation
19	Assembly and Disassembly of UMC100.3 and IO Modules
19	Supplying the UMC and IO Modules
19	Connecting the IO Modules DX111.0 and DX122.0
20	Wiring DX1xx Inputs and Outputs
21	Connecting the VI15x Voltage Module
22	Wiring VI15x Inputs and Outputs
23	Connecting the AI111.0 Inputs
24	Connecting more than one expansion module
24	Connecting Contactors
26	Motor Wiring
27	Connecting External Current Transformers (CTs)
29	Connecting the UMC100-PAN LCD Panel
30	Using the UMC100.3 in a PROFIBUS DP Network
32	Using the UMC100.3 in a DeviceNet Network
33	Using the UMC100.3 in a MODBUS RTU Network
34	Using the UMC100.3 in withdrawable applications
35	3 Commissioning
35	Commissioning Steps
37	Test Position
38	4 Configuring the Motor Protection Functions
38	General Information
38	EOL and Current based Protection Functions
52	Function Overview
53	Total Harmonic Distortion
62	5 Configuring the Motor Management Functions
62	Starting and Stopping the Motor

67	Emergency Start
67	Limit the Number of Starts
69	Checkback Monitoring
69	Using the Digital UMC Inputs
71	Single Phase and Three Phase Operation Mode
71	Stand-Still Supervision
71	Run-Time Supervision
72	Control Functions
96	Controlling Resistive Loads
97	6 Configuring the Communication Interfaces
97	Setting the Bus Address
97	Specific Communication Settings for Modbus RTU and DeviceNet
98	Address Check when using UMC in Motor Control Centres
99	Defining the Bus Fault Reaction
99	Ignore Block Parameters
99	Change I/O data length on the fieldbus
100	Adjust cyclically transmitted Monitoring Words
100	Special considerations for backwards compatibility on DeviceNet and PROFINET
101	7 Using Expansion Modules
101	Using a Digital IO Module (DX111.0/122.0)
102	Using a Voltage Module (VI150.0/155.0)
102	Using an Analog Input Module (AI111.0)
103	8 The LCD Control Panel UMC100-PAN
103	Overview
104	Monitoring Status Information
104	The Menu Tree
110	Adjusting Parameters
113	Starting and Stopping the Motor
115	9 Error handling, maintenance and service
115	Error handling of the UMC
115	UMC100.3 fault indication
115	Fault messages
120	Resetting parameters to factory defaults
120	Resetting the password
120	Reading, setting and resetting maintenance counters
120	I/O-Module status LEDs
121	Replacing a UMC100.3

121	Replacing an I/O Module
121	Requesting support
121	Check the configuration
122	10 Safety and Commissioning Notes for Motors in Ex Areas
122	Introduction
122	Safe state
123	Safety functions
123	Configuring the safety functions
124	Maintenance and repair
125	Tests
125	Configuration via fieldbus
126	11 Parameters and Data Structures on a Fieldbus
126	Monitoring Data
126	Command Data
127	Diagnosis Data
128	Accessing Data on PROFIBUS / PROFINET
128	Accessing Data on Modbus / ModbusTCP
128	Accessing Data on DeviceNet
128	Accessing Data on EtherNet/IP™
129	Parameter Organisation
129	Motor Management Parameters
133	Protection Parameters
136	Communication Parameters
138	IO Module Parameters
142	UMC Display Parameters
143	Function Block Related Parameters
144	All Parameters Sorted by parameter number
146	12 Basic Circuit Diagrams
146	Direct Starter with IO modules and 110-240 V supply
147	Emergency Stop Function for Direct Starter, Category 4
148	Emergency Stop Function for Reversing Starter, Category 4
149	13 Technical Data
149	UMC100.3
150	Tripping time for warm motor for three-phase and single-phase symmetrical loads
151	Tripping time for cold motor for three-phase and single-phase symmetrical loads
154	Performance Data
155	UMC100-PAN

155	DX111.0 and DX122.0
158	VI150.0 and VI155.0
159	AI111.0
160	EMC UMC100.3, AI111.0, DX1xx.0 and VI15x.0
160	EMC VI15x.0
161	Operational altitude above sea level
161	Characteristic values according to IEC/EN 61508
161	Characteristic values according to ISO 13849
162	Dimensional drawings

How to get started

There are many options for using the UMC100.3. Not all functions are required in all cases. Therefore the documentation is split into separate parts. You only need to read the parts that are relevant for your application. The following manuals exist.



UMC100.3 ATEX Technical Manual **2CDC135033D0202**

This is the main technical description and must always be read carefully before using the UMC.

 You are now reading this manual



FIM UMC Edition **2CDC135069M0201**

This manual describes the configuration tool FIM UMC Edition in combination with UMC100.3. It is based on the Field Device Integration (FDI) technology standard and can be used for configuration, monitoring and operating. If you plan just to configure the UMC100.3 with device description files such as GSD (PROFIBUS), GSDML (Profinet) or EDS (DeviceNet and EtherNet/IP) or via the LCD control panel, you do not need to read this manual. .



UMC100.3 Custom Application Editor **2CDC135034D0201**

This manual describes how to create custom applications for the UMC100.3. The Custom Application Editor is only required if the logic built into the UMC100.3 does not fulfill your requirements. The Custom Application Editor is part of the FIM UMC Edition configuration software.



There are 2 documents that you should read:

FIM UMC Edition (describes the general handling of the software)

UMC100.3 Custom Application Editor (describes the function blocks of the editor)



Communication Interfaces

Whenever the UMC100.3 is to be connected to a fieldbus, read the appropriate communication interface manual. Presently the following communication interfaces can be used together with UMC100.3:

PROFIBUS DP	PDP32.0	2CDC192016D0202
DeviceNet	DNP31.0	2CDC192005D0201
MODBUS RTU	MRP31.0	2CDC194005D0201
Modbus TCP	MTQ22.0	2CDC194003D0202
PROFINET IO	PNQ22.0	2CDC192015D0201
PROFINET IO (S2)	PNU32.0	1SAC200130M0001
EtherNet/IP™	EIU32.0	2CDC135055D0201

New features in comparison to preceding versions

1SAJ520000R0101 / 1SAJ520000R0201 -> 1SAJ530000Rx100 / 1SAJ530000Rx200

New protection functions

- The new analog input module AI111.0 adds three analog inputs to the UMC100. Up to two AI111.0 can be connected to the UMC100.3 at the same time. See chapter 4, section "RTD based Temperature Supervision and Analog Inputs" for details.
- Single phase / three phase operation modes

New motor management functions

- Control functions for load feeder and softstarter
- Standstill and operating hours supervision

Fieldbus communication

- The new communication adapters use no M12 connectors and cables anymore.
- Standard fieldbus cables and fieldbus connectors can be used.

Supply voltage

- There is an additional UMC100.3 version for 110 V AC/DC to 240V AC/DC supply voltage.
- A 24 V DC supply output is available to supply the expansion modules.

Other new functions

- The LCD panel offers a USB interface for configuration via laptop
- The LCD panel supports Polish as an additional language
- Availability to display all three phase currents

New features in UMC100.3

Additional functions in newer releases; Firmware version can be identified with operator panel, maintenance menu

- V3.05
- New Ethernet settings via operator panel
 - More Modbus RTU settings
 - Wrong frequency identified by voltage module VI15x.0 results in warning only and does not trip the motor



The UMC100.3 is fully backwards compatible with the previous version and replaces it. To use the new features via fieldbus new fieldbus device description files have to be used. Therefore updated GSD and EDS files are available on the ABB web site. See chapter "11 Parameters and Data Structures on a Fieldbus" for details.

To replace a defective device 1SAJ520000R0x01 against a 1SAJ530000Rxy00, the device description files need not be changed.



The UMC100.3 size is very similar to the previous UMC100.0 version. Some connector positions have changed. Please see technical data for details.



The UMC100.3 ATEX and UMC 100.3 standard have the same functionality. In the following, UMC 100.3 ATEX is called UMC 100.3.

1 System Overview

The Universal Motor Controller (UMC) is an intelligent motor controller for 3-phase AC induction motors combining the two classical functions of motor protection and motor management in a single device plus offering diagnostic and fieldbus communication. The device functions can be adjusted in a wide range to cover the needs of different industries. UMC100 is a further development of the UMC22.

Function Overview

Protection Functions

- The UMC provides comprehensive motor protection including phase failure detection, adjustable motor protection for stalled motors during startup or normal operation, configurable current limits to generate trips or warnings and many more.
- Overload classes 5E, 10E, 20E, 30E and 40E
- Thermistor motor protection (PTC)
- Analog inputs for PT100/PT1000 based protection
- Analog inputs for standard signals (0 - 10 V; 0/4 - 20 mA)
- Earth fault detection (e.g. when used in IT networks)
- Power and voltage based protection functions
- Supervision of the network quality (Total Harmonic Distortion)
- One device type covers the whole current range starting from 0.24 up to 63 A.
For higher currents up to 850 A additional current transformers are available.

Communication

- The UMC100.3 can be integrated into different fieldbus and ethernet networks such as PROFIBUS DP / PROFINET IO, DeviceNet, MODBUS / ModbusTCP and EtherNet/IP™ via various fieldbus and ethernet communication interfaces.
All measured data, status signals and parameters can be accessed via communication.
- It is also possible to use the UMC100.3 as a stand-alone device without any fieldbus communication.
- The motor protection and motor management is fully functional in the event of a bus failure.
- The communication interface and the UMC can be mounted separately. This offers many benefits in MCC applications especially for withdrawable systems.
- Parameterisation of the protection and control functions can be carried out with the device description files as defined by the different fieldbuses (e.g. GSD for PROFIBUS). In addition, configuration software based on the FDI standard offers the possibility of convenient device configuration via laptop.
- Selecting the cyclically transmitted analog values by parameter

Motor Management, Inputs and Outputs

- The UMC100.3 provides six digital inputs, three relay outputs and one 24 V output. Therefore a wide number of control functions can be covered from the base device.
- If further inputs or outputs are needed, the basic device can be expanded with an expansion module. That provides an additional eight digital inputs, four relay outputs and an analog output for driving an analog meter.
- Supported standard configurations are direct starter, reversing starter, star-delta starter, actuator, inching mode and many more.
- The digital inputs can be configured in many ways to adapt the behaviour of the UMC100.3 to specific user requirements.
- To execute customer specific applications the UMC100.3 allows free programming of its internal logic. Function blocks for signal adjustment, boolean logic, timers, counters ... are available (see manual "Custom Application Editor").
- Different control stations (DCS, DI, Operation Panel ...) with individual, adjustable release opportunities are available.

Metering, Monitoring and Diagnosis

- Rapid, comprehensive diagnostics and operating status information is available on the UMC100.3 itself (LEDs), on the LCD panel (clear text messages), via fieldbus or on a laptop connected directly or via fieldbus to the UMC.
- The fully graphic, multi-language LCD panel allows configuration, control and monitoring of the UMC and its inputs and outputs.
- Available diagnosis includes motor, bus and device status, maintenance counters such as number of starts and overload releases, remaining cooling time, etc.

Function Block Programming

- The UMC100.3 has a set of predefined applications built in. These applications are built on the basis of function blocks and can be used directly without the need for a programming tool.
- Custom applications can be created in a convenient way. The custom application editor is integrated in the configuration tool.
- You can monitor an application online to support you during development and testing.
- Control and protection related and general purpose function blocks are available: boolean logic, timers, counters, blocks representing the hardware, starter functions, ...
- There are basic function blocks like boolean blocks that have no parameters. But there are also very powerful function blocks such as the multifunction inputs or the starter blocks. Such blocks have parameters accessible via LCD operator panel and fieldbus. By setting the block parameters you can adjust the behaviour of the blocks and the application to your needs.



Please note:

It is not necessary to change the function block application if the predefined applications fulfill your requirements. But if you have specific requirements you can enable the customer application mode and adapt an existing application to your needs or even create your own one.

This is described in the manual "Custom Application Editor" (see section "How to get started").

Compatibility to previous versions of UMC100.3

Hardware

The UMC100.3 is mechanically very similar to the previous UMC100 and UMC22. The new UMC100.3 is a little bit deeper to offer enough space for the AC power supply. Also the location of some connectors has changed slightly. See technical data for details.

Fieldbus Interface

The UMC100.3 and the new communication interfaces do not use M12 connectors anymore. So it is not possible to plug-on a FieldbusPlug with M12 connector directly on the UMC anymore. But electrically the interface is still the same. So replacement of single components is possible.

System Integration

UMC100.3 is backwards compatible regarding the cyclic IO data and parameters. An existing FieldbusPlug or UMC can be replaced with a new component without any change in the control system. If new features of UMC100.3 should be used a new device description file (e.g. GSD) must be used of course.

Other UMC100.3 versions

This manual describes UMC100.3 ATEX. There are also standard versions available:

Please refer to manual 2CDC135032D0204 for those versions.

Description of Components

UMC100.3

The following diagram shows the terminals, monitoring and operating elements of the UMC100.3. The UMC is shown with PDP32.0 as an example for a communication interface.

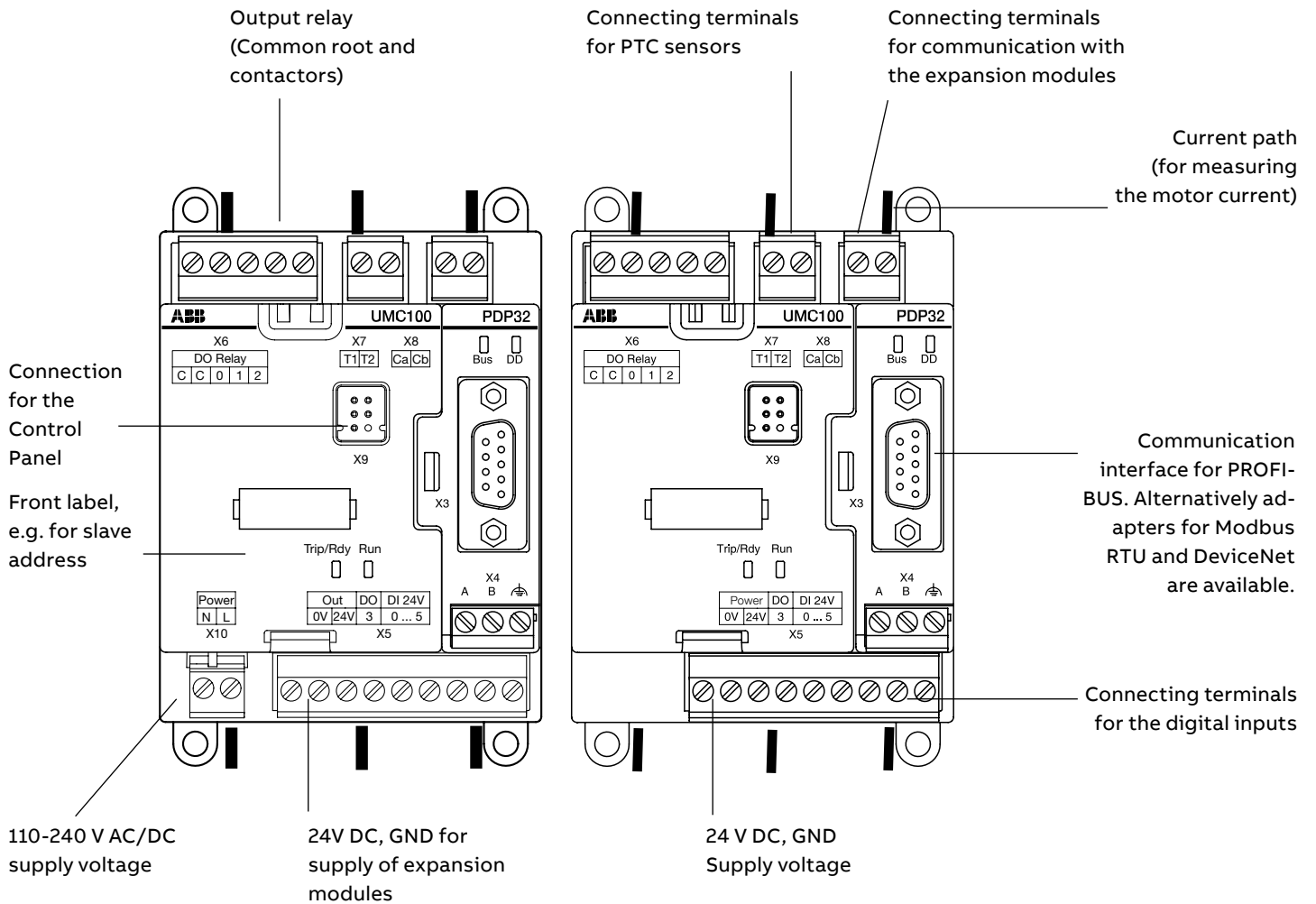

After powering on, the UMC100.3 performs a self-test of its hardware and checks the configuration for consistency. In the event of a failure, a self-test fault is generated and signalled. Replace the device in such a case. After a successful self-test the UMC enters the operational state.



For the 24 V DC power supply, always use an SELV or PELV power supply unit!

Building Blocks of UMC100.3

The next diagram shows the major function blocks of the UMC100.3 and the data flow among them.

The upper main block contains the protection-related functions. Signals from different signal sources are evaluated from the trip unit. Depending on the configuration either a trip or a warning can be created. The motor protection always has priority regarding control of the relay outputs. In case of a protection trip the relevant contacts are opened and thereafter the motor is stopped. If the device fails, the watchdog opens the relay outputs automatically for safety reasons. There is no possibility to bypass this watchdog.

The main inputs for motor protection are the current measurement and the thermistor sensor. The current measurement provides information about the actual motor current in the three phases. An advanced motor model uses the current information and calculates the corresponding motor temperature. At a certain level it will trigger an overload trip. The thermistor input measures the PTC resistance. Based on the resistance the cold and hot state of the motor can be distinguished. Also short-circuit or wire break conditions can be detected.

The lower main block contains the control-related functions. Incoming commands from the panel, the digital inputs or the fieldbus are ranked from the control place selection block according to the user settings and then forwarded to the active starter function.

The starter function block controls the relay outputs depending on its input signals and the actual state. Additionally monitoring signals are prepared for the LCD display, the UMC100.3 signalling LEDs and the fieldbus monitoring and diagnosis telegrams. All these blocks run in the so-called logic engine. It is possible to change the application which is running there but usually the pre-defined applications will be sufficient. Further information about the creation of custom applications can be found in the Custom Application Editor manual.

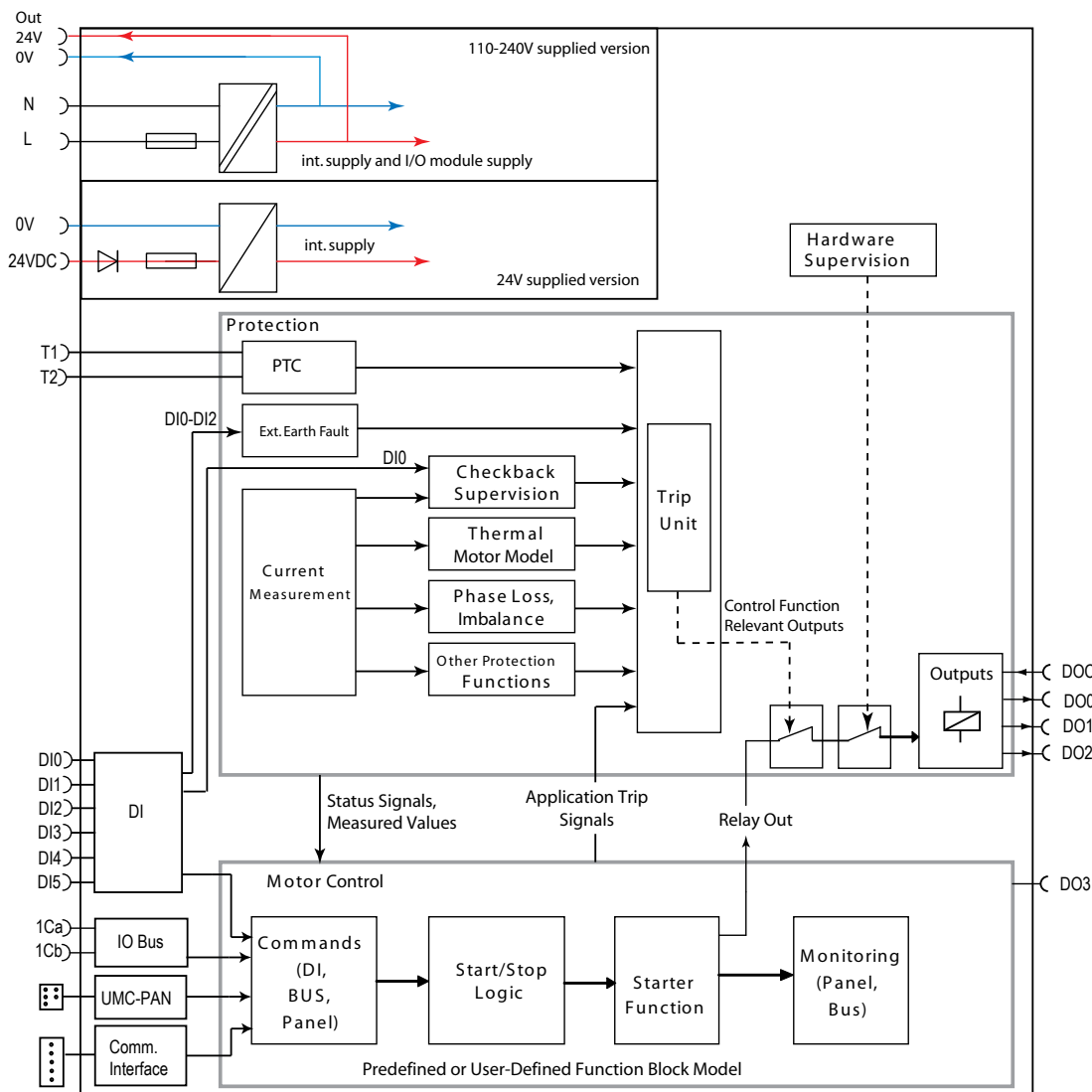

Overview of the major building blocks of UMC100 and the data flow among them.

DX111.0

The DX111.0 expands the input and output channels of the UMC100.3.

It provides eight digital inputs for 24 V DC, four relay outputs and an analog output to drive an analog instrument.

The following diagram shows the terminals and monitoring elements of the DX111.0 module.

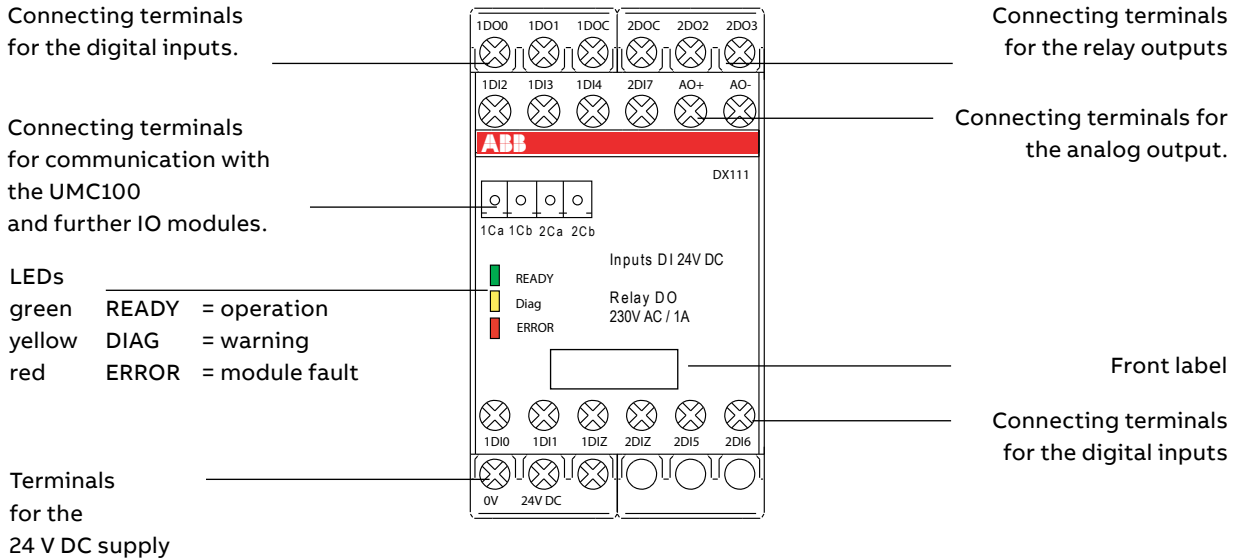

DX122.0

The DX122.0 expands the input and output channels of the UMC.

It provides eight digital inputs 110 V AC - 230 V AC, four relay outputs and an analog output to drive an analog instrument.

The following figure shows the terminals and monitoring elements of the DX122.0 module.

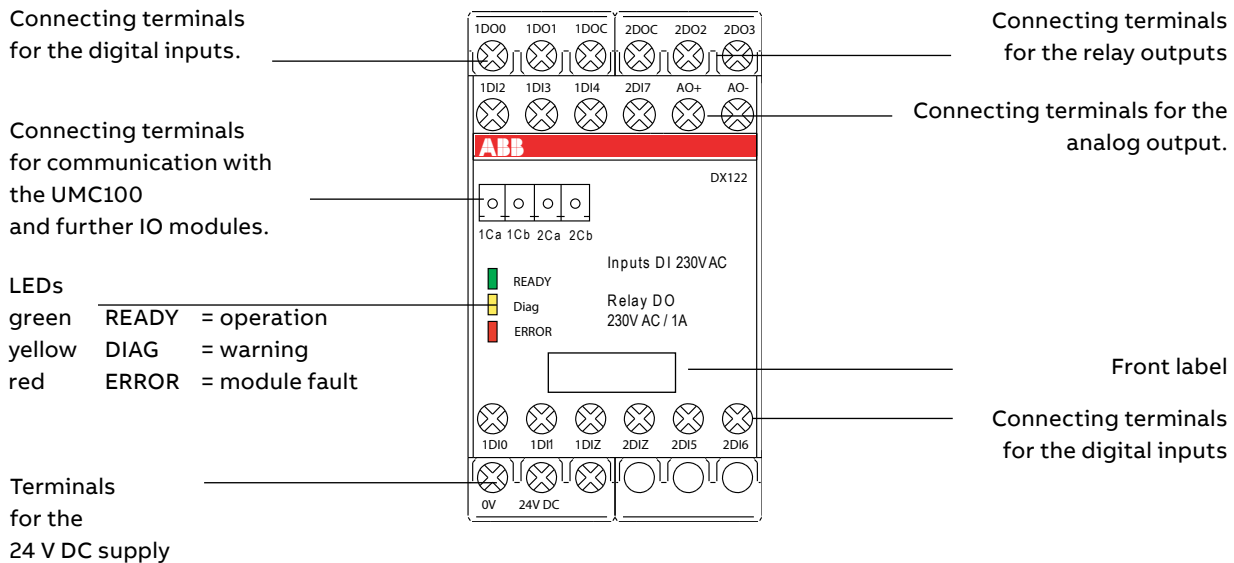

VI150.0

The VI150.0 adds voltage and power protection functions to the UMC. It provides three voltage inputs and one relay output. It can be used in three- and single phase operation mode.



The module can be used with grounded systems only (e.g. TN-C / TN-S systems according to IEC 60364).

The following figure shows the terminals and monitoring elements of the VI150.0 module.

Connecting terminals for the line voltage inputs.

Connecting terminals for communication with the UMC100 and further IO modules.

LEDs
 green READY = operation
 yellow DIAG = warning
 red ERROR = module fault

Connecting terminals for the relay output

Terminals for the 24 V DC supply

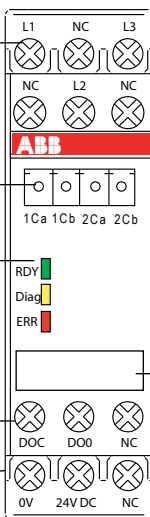

Front label

VI155.0

The VI155.0 adds voltage and power protection functions to the UMC. It provides three voltage inputs and one relay output. It can be used in three- and single phase operation mode.



The module can be used with grounded and ungrounded systems (e.g. TN or IT-systems according to IEC 60364).

The following figure shows the terminals and monitoring elements of the VI155.0 module.

Connecting terminals for the line voltage inputs.

Connecting terminals for communication with the UMC100 and further IO modules.

LEDs
 green READY = operation
 yellow DIAG = warning
 red ERROR = module fault

Connecting terminals for the relay output

Terminals for the 24 V DC supply

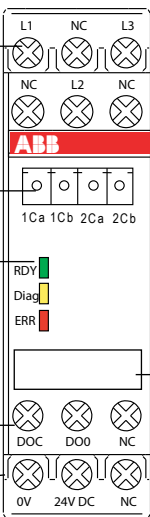

Front label

AI111.0

The AI111.0 module provides three analog inputs. The type of the inputs can be configured by parameters as temperature inputs (e.g. PT100, PT1000, NTC) or as standard signal inputs (0 - 10 V, 0/4 - 20 mA).

Up to two AI111.0 modules can be connected to the UMC100.3 to offer six analog inputs in total. For the first module the terminal named ADR must be left open. For the second module the input named ADR must be connected to 24 V DC.

Connecting terminals for analog input channel one

Connecting terminals for analog input channel two

Connecting terminals for communication with the UMC100 and further IO modules.

LEDs
 green RDY = operation
 yellow Diag = warning
 red ERR = module fault

Connecting terminals for analog input channel three

Terminals for the 24 V DC supply

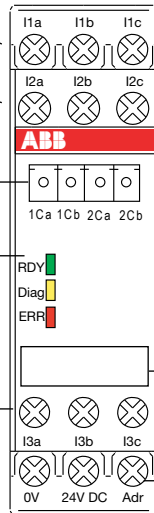

Front label

Terminal to select module number

Configuration Tool

Asset Vision Basic is the tool to configure the UMC100.3 via a laptop.

Asset Vision Basic is jointly used between ABB Instrumentation and ABB Control Products. Therefore it enables a wide range of ABB products to be configured such as motor controllers, soft starters, flow meters and many more. It is based on the FDT/DTM standard which also enables the configuration of third-party products that are connected at the same bus segment. You can parameterise the UMC100.3 both online and offline. In offline mode the configuration can be fully prepared and then later on loaded into the device(s). If a connection to a device exists, online-monitoring of all measured values, maintenance counters etc. is possible.

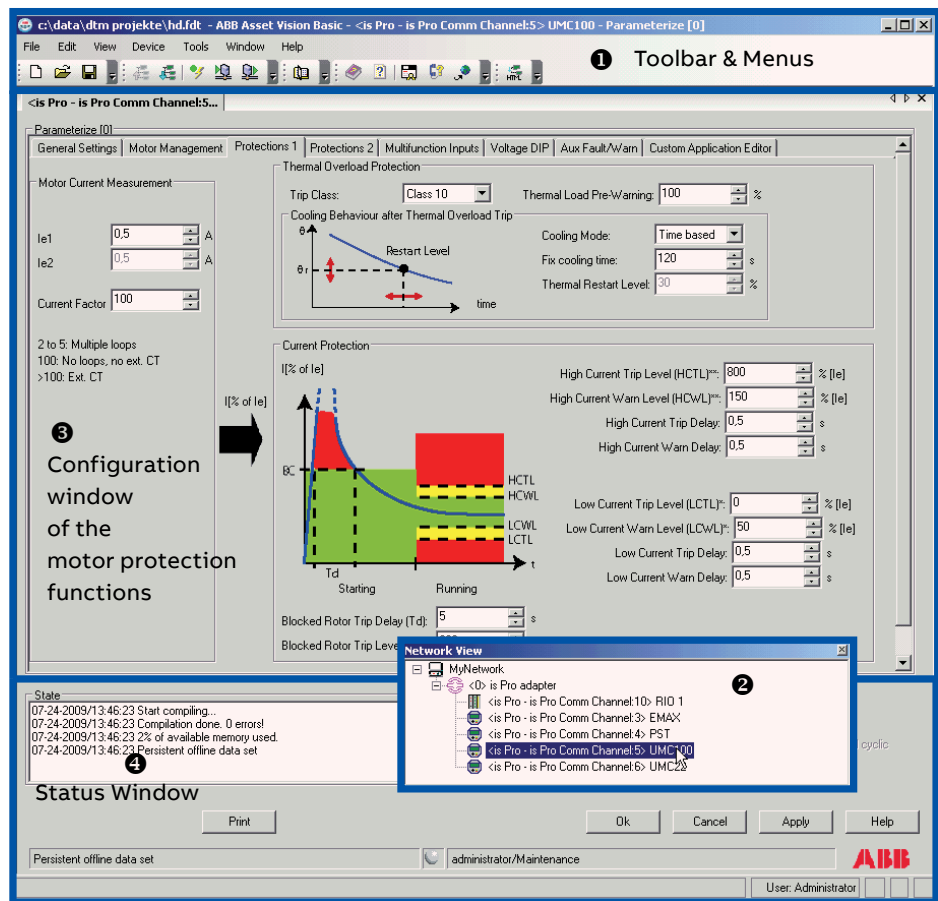

Tree view of all devices on the bus line

UMC100.3 configuration tool Asset Vision Basic with the motor protection configuration window '3'. In '1' the toolbar of the tool is shown. '2' provides a network view with all the devices accessible on the PROFIBUS DP line. '4' contains a window to display messages and buttons to quit or adopt the parameter changes.

The diagram above shows the configuration tool which allows intuitive configuration of all UMC100.3 functions. In this example the window to configure the motor protection parameters is shown. In similar windows all other parameters can be configured. Other views enable the monitoring of the diagnosis information, the visualisation of bus monitoring, command data and much more.

Change of configuration tool

Beginning 2019, the Asset Vision Basic software will be replaced by the FIM UMC Edition software. This software uses the FDI standard, the latest standard for the configuration of field devices in process industry.

FIM UMC Edition

ABB's Field Information Manager (FIM) software is based on the FDI standard and is used for the configuration of a wide range of ABB products, such as ABB Instrumentation devices or ABB Control Products. The UMC100.3 can be configured both online and offline. In "monitoring" mode, all data is shown online, while in "operating" mode it is also possible to test a configuration by using start and stop commands and by watching the status online.

For advanced applications, a Custom Application Editor is included that enables the creation of individual motor starter functions. Communication from laptop to UMC100.3 can be achieved using a simple serial link cable or via Profibus.

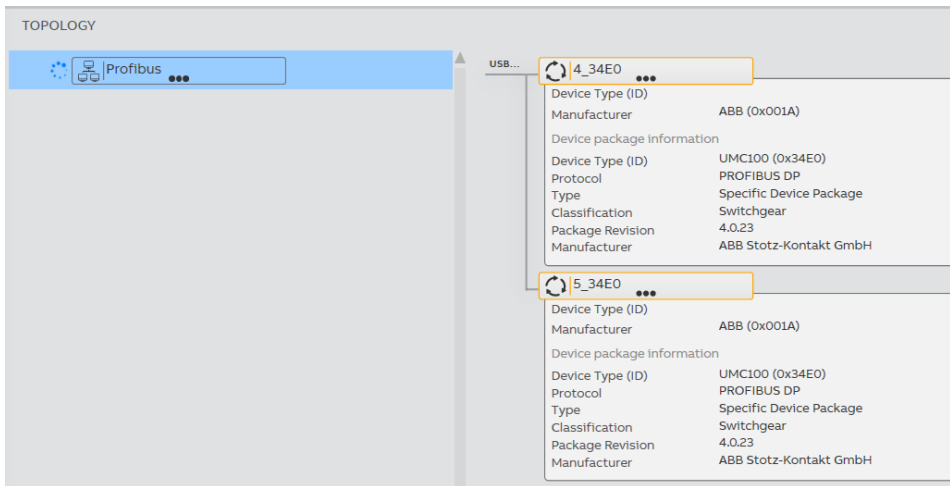

Profibus network with 2 UMC100.3, slave 4 and 5

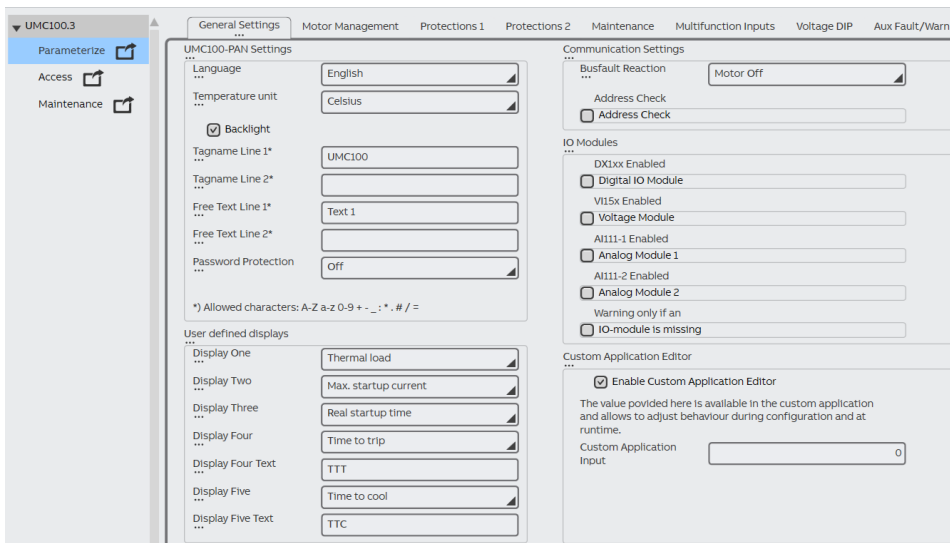

Screenshot shows the "parameterize" mode. All settings are organized in functional groups.

LCD Panel

The Control Panel UMC100-PAN is an accessory for the UMC100.3 and can be used for monitoring, control and parameterisation of the UMC100.3. It can be directly plugged on the UMC100.3 or mounted separately on the panel door using the mounting kit. Some of the main features are:

- Fully graphic, user interface
- Selectable language: English, Finnish, French, German, Italian, Polish, Portuguese, Russian, Spanish
- Start and stop of the motor and acknowledgement of faults.

The following diagram shows the UMC100-PAN with the monitoring and operating elements:

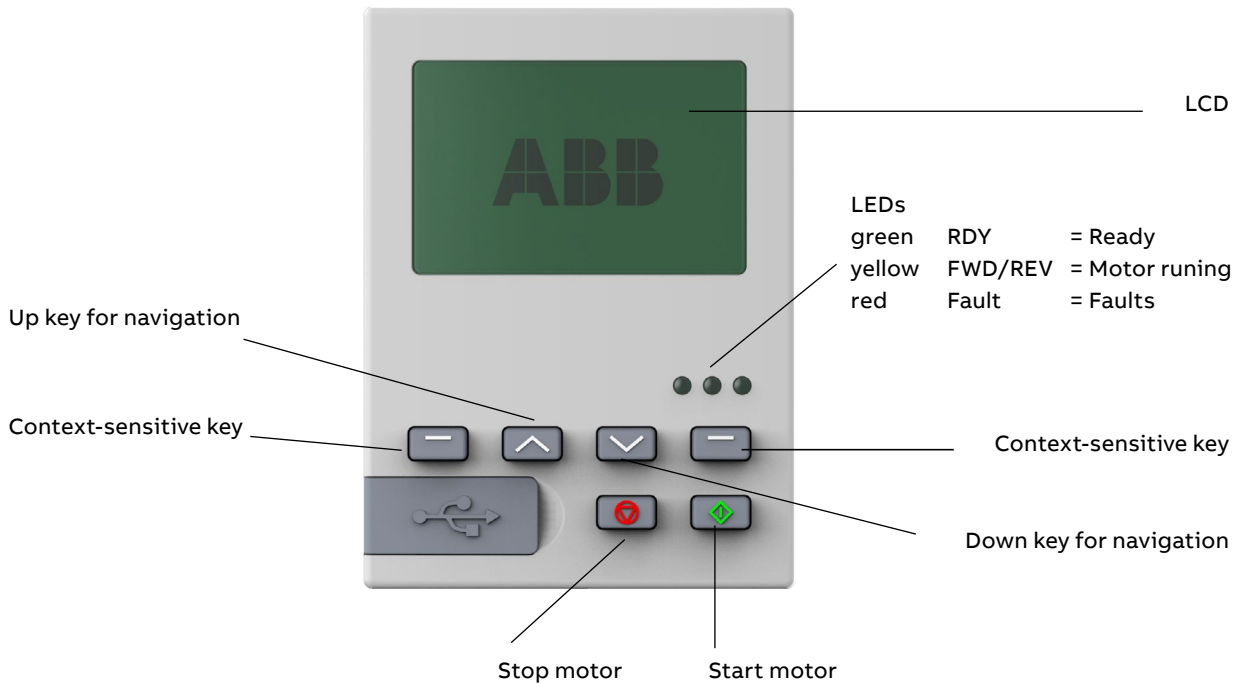

2 Installation

Assembly and Disassembly of UMC100.3 and IO Modules

You can attach the UMC100.3 and the IO modules as follows:

- Snap-on mounting onto a 35 mm standard mounting rail, without tools (UMC100.3 and IO devices)
- Mounting via screws on a mounting plate (UMC100.3 only)

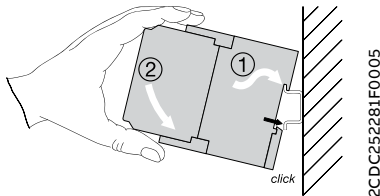

Assembly

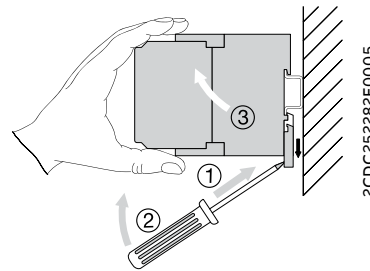

Disassembly

Supplying the UMC and IO Modules

If 24 V DC is available use the UMC100.3 DC type and connect both the UMC100.3 and the IO modules to the 24 V DC supply. If 110-240 V AC/DC is available use the UMC100.3 UC. The UMC100.3 UC provides a 24 V DC supply output. This output is intended to supply the IO modules and digital inputs with 24 V DC. It is not intended to supply contactor coils.



The UMC100.3 UC supply output is limited to 250 mA for an environmental temperature of 60 °C and to 450 mA at 50 °C. The total current consumption of the connected IO modules, transistor output DO3 and communication interface must not exceed that limit. Details about the current consumption of the IO modules and calculation examples are available in chapter "13 Technical Data".

Connecting the IO Modules DX111.0 and DX122.0

The modules DX111.0 and DX122.0 increase the number of inputs and outputs provided by the UMC100.3. The UMC100.3 can be expanded with one digital IO module. Thus, 8 additional binary inputs, four additional relay outputs and one analog output for driving an analog indicator instrument are available. The IO modules are connected via terminals Ca and Cb (see below) to the UMC100.3. Because of limited installation space it might be desirable to mount the IO modules separately from the UMC100.3. This can be carried out without any problems as long as the maximum cable length is not exceeded.

The following limits apply when connecting an IO module:

- Either the DX111.0 or DX122.0 can be connected. It is not possible to connect both of them to the UMC100.3.
- The distance between the UMC100.3 and the IO modules must not be longer than 3 m.

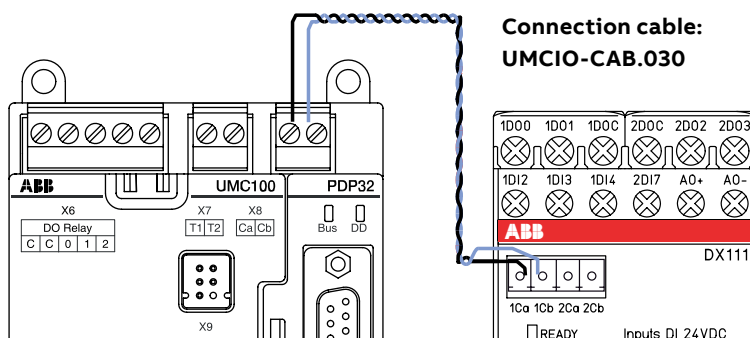

Wiring is shown for module DX111.
It is the same for other modules.

Wiring DX1xx Inputs and Outputs

The diagram below shows the block diagram and wiring for both the DX111 and the DX122 modules.

The digital inputs are galvanically isolated.

The common ground for the inputs 1DI0-4 must be connected to 1DIZ.

The common ground for the inputs 2DI5-7 must be connected to 2DIZ.

If no separate grounds are necessary, 1DIZ and 2DIZ can be connected to each other.

The relay outputs groups 1DO1/1DO2 and 2DO1/2DO2 have separate roots each.

The analog output (AO+/AO-) is intended to drive an analog instrument which can be used to display the motor current. It can be adjusted as a current or voltage output.

Open wire and short-circuit faults are detected.

Supported output levels are:

- 0/4 - 20 mA
- 0 - 10 mA
- 0 - 10 V

The output is scaled in a way that a motor current of 0 % results in 0 % at the output and a motor current of 200 % results in 100 % output level. The predefined scaling can be changed with the help of the custom application editor.

Example if the output is set as voltage output:

0 % motor current $\rightarrow U_{out} = 0 \text{ V}$, 200 % motor current $\rightarrow U_{out} = 10 \text{ V}$.

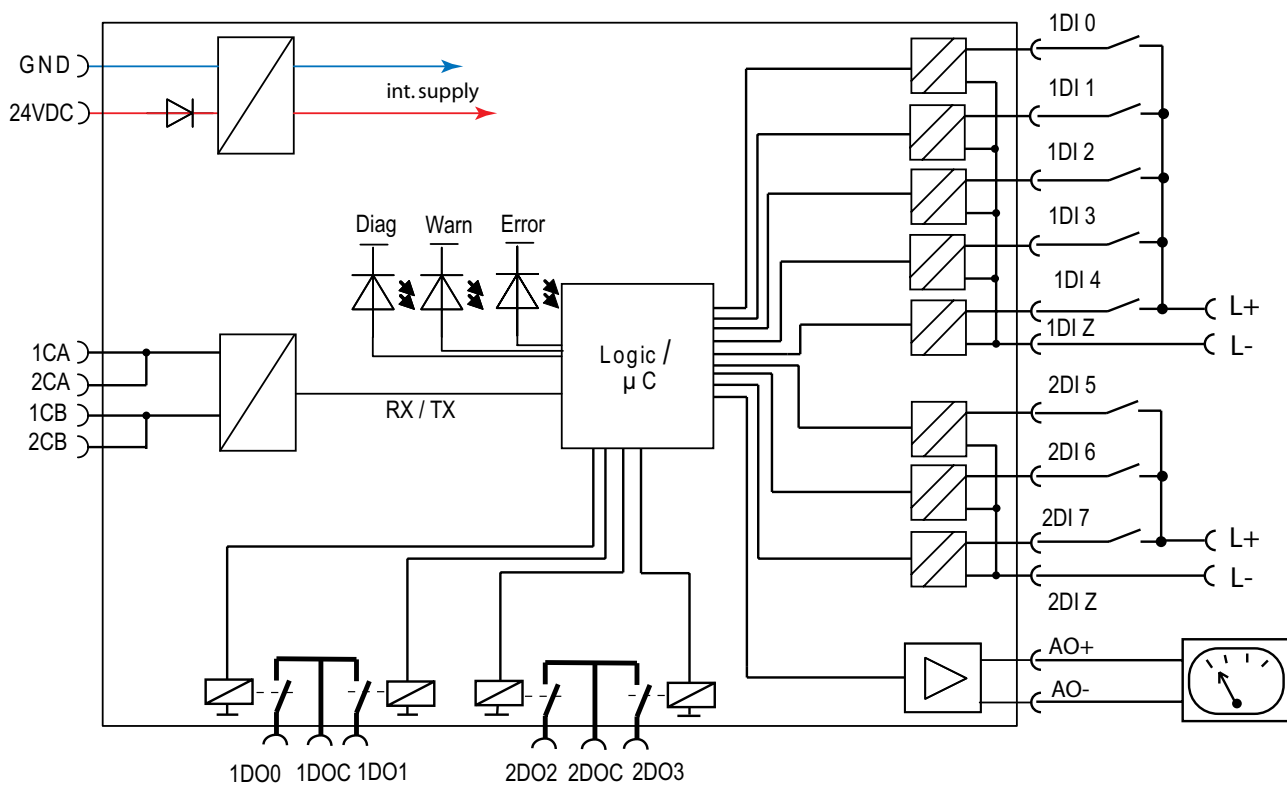

	L+	L-
DX111	+24VDC	GND
DX122	230VAC	N

Wiring diagram of the DX111.0 and DX122.0 module

Connecting the VI15x Voltage Module

The modules VI150.0 and VI155.0 allows to measure the motor supply voltage, cosphi (power factor) and to calculate thereof the active power and other values.



There are two module variants. The VI155 module can be used in grounded (TN) and ungrounded (IT) networks.
The VI150 module can only be used in grounded networks (TN).



When using a voltage module the phase order at the UMC must be L1 to L3 from left to right looking from top.
In single phase operation mode connect N->L1 and L->L2



Note that the connection cables for voltage measurement (terminals marked with L1, L2, L3) may require additional cable protection



Don't connect any cable to the VI1xx terminals marked with NC (not connected)



Note that a distance of 10 mm left from the terminal L1 and right from the terminal L3 to the next device might be required for voltages >230 V AC or > 400 V AC respectively, depending on the equipment mounted left and right of the module.

The module is connected via terminals Ca and Cb (see below) to the UMC100.3.
It is possible to mount the module separately from the UMC100.3.

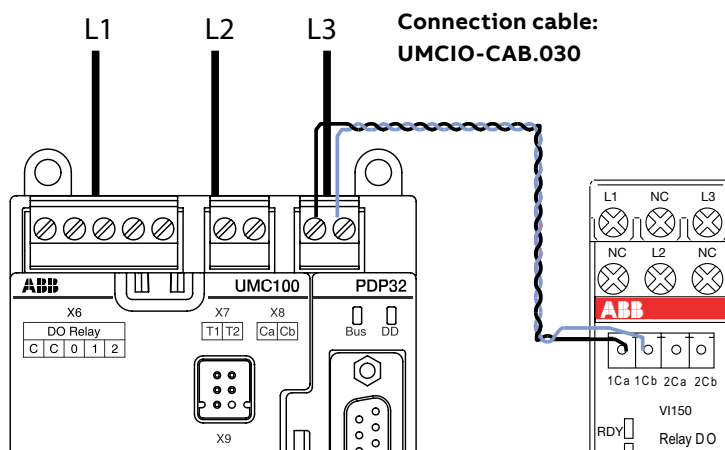

Wiring is shown for module VI150. It is the same for VI155.

Connection between UMC100.3 and voltage module

Wiring VI15x Inputs and Outputs

The diagram below shows the block diagram and wiring of both the VI150 and the VI155 modules. The relay output is a normally open contact and can be freely used. The inputs L1, L2, L3 must be connected to corresponding supply phases in three phase network. The inputs L1 must be connected to N and L2 to L in a single phase network. The 0 V of the VI150 supply must be connected to ground for proper measurement.

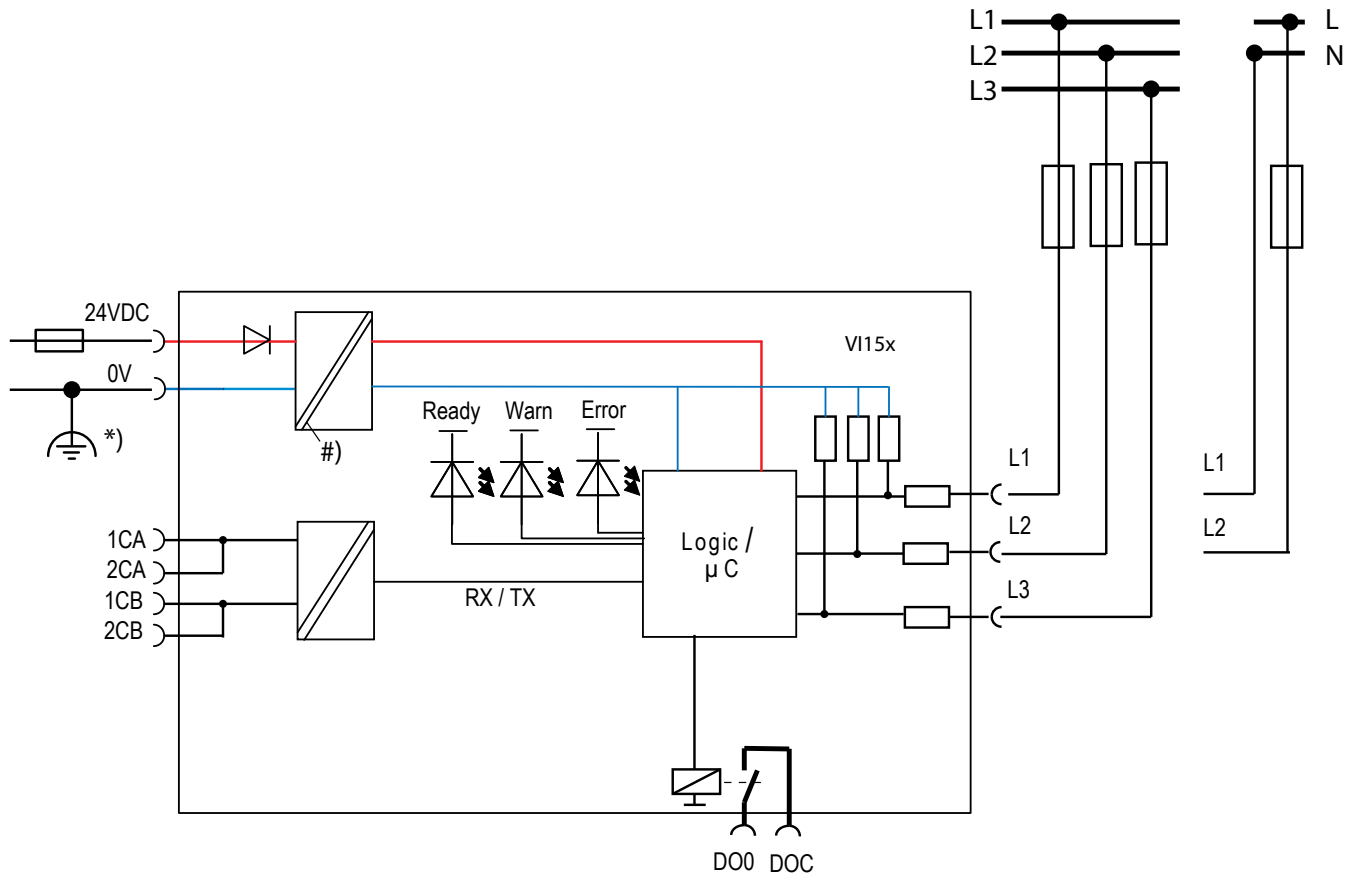

*) Functional earthing only VI150. Connection at the 24 V DC power supply

#) Only VI155

Wiring diagram of the VI15x modules

Connecting the AI11.0 Inputs

The module AI11.0 allows to measure three temperatures, voltage (0...10V) and current (0/4...20mA). The diagram below shows the block diagram and wiring of the analog input module.



It is possible to connect up to two AI11 modules to the UMC100.3. Connect the Adr terminal to 24V DC at the second module.



Avoid parallel runs of power cables or other noise sources to the analog input signal cables. We recommend to use shielded cables (see technical data).

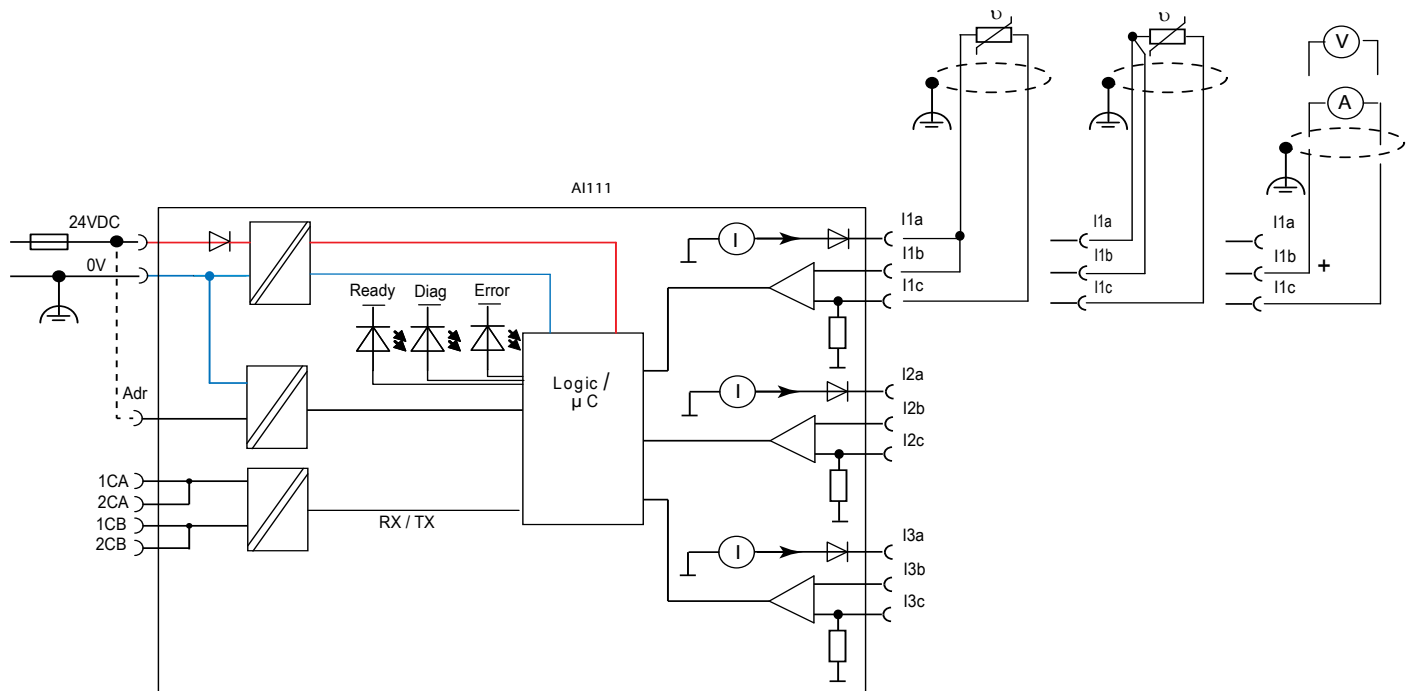

Wiring diagram of the AI11 modules. Depending on the analog input source choose the correct terminals

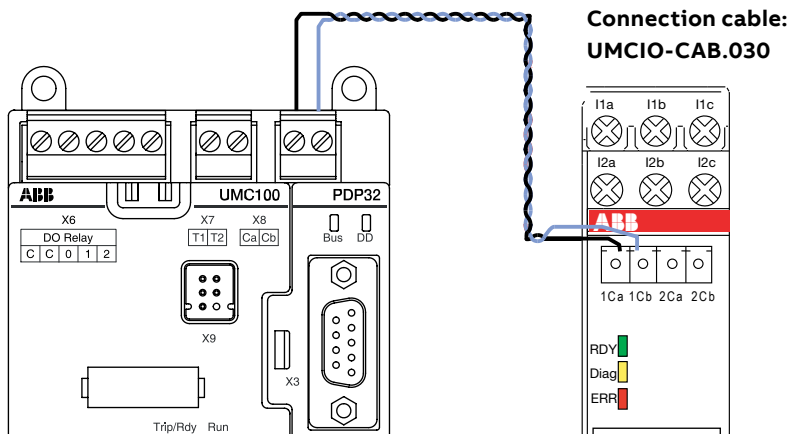

Connection between UMC100.3 and the AI11 module

Connecting more than one expansion module

To connect several expansion modules to the UMC100.3 use the UMCIO-CAB cable to connect the first module with the UMC. And use the IOIO-CAB cable to connect the first module with the second module and so on. The module order does not matter.

Connecting Contactors

Actual ABB contactors - all currents for 230 V AC (Extract):

Contactor type	Inrush current [A]	Holding current [A]	Inrush power [VA]	Holding power [VA]
B6S-30-10-2.8 ¹⁾	0.01	0.01	2.4	2.4
AF09Z - AF38Z	0.07	0.007	16	1.7
AF40 - AF65	0.11	0.017	25	4
AF80 - AF96	0.17	0.017	40	4
AF116 - AF146	0,56	0.026	130	6
AF190, AF205	0,96	0.03	220	7
AF265 - AF370	1.67	0.08	385	17.5
AF400, AF460, AF580, AF750	4.15	0.05	955	12

¹⁾ The contactor B6S-30-10-2.8 (24 V DC) is recommended as interface contactor due to its internal spark suppression.



Spark suppression is necessary for all types except the AF types to maintain a reasonable service life.

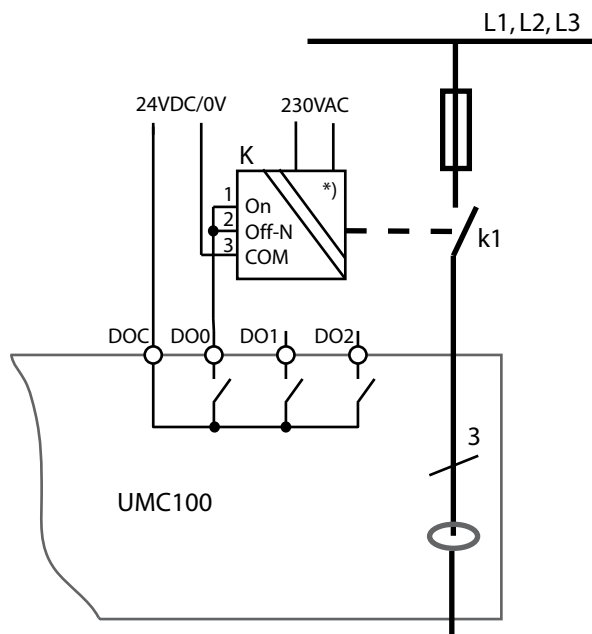

Connection of contactors with electronic interface (AF types) to the UMC100.3

*) Slide switch on the left side to position 'PLC' (up)

Interfacing contactors with peak current > 0,5 A: Types A50 and larger

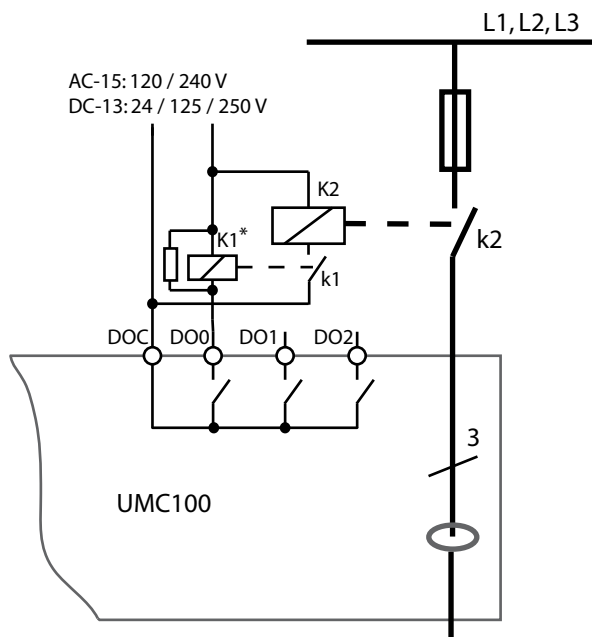

K2: Contactors with peak current >0.5 A

For checkback, the auxiliary contact of the main contactor has to be used!

*) e.g. BS6-30-10-28

In this case the shown spark suppression is not needed (built in)

Motor Wiring

The following diagram shows different methods of connecting a motor. For a reliable motor protection it is essential to set the correct nominal current I_e .

Note:
For inner-delta wiring the parameter Current Factor needs to be set to 1.73 ($=\sqrt{3}$). The $\sqrt{3}$ circuitry is normally used for larger motors to reduce the current transformer size.

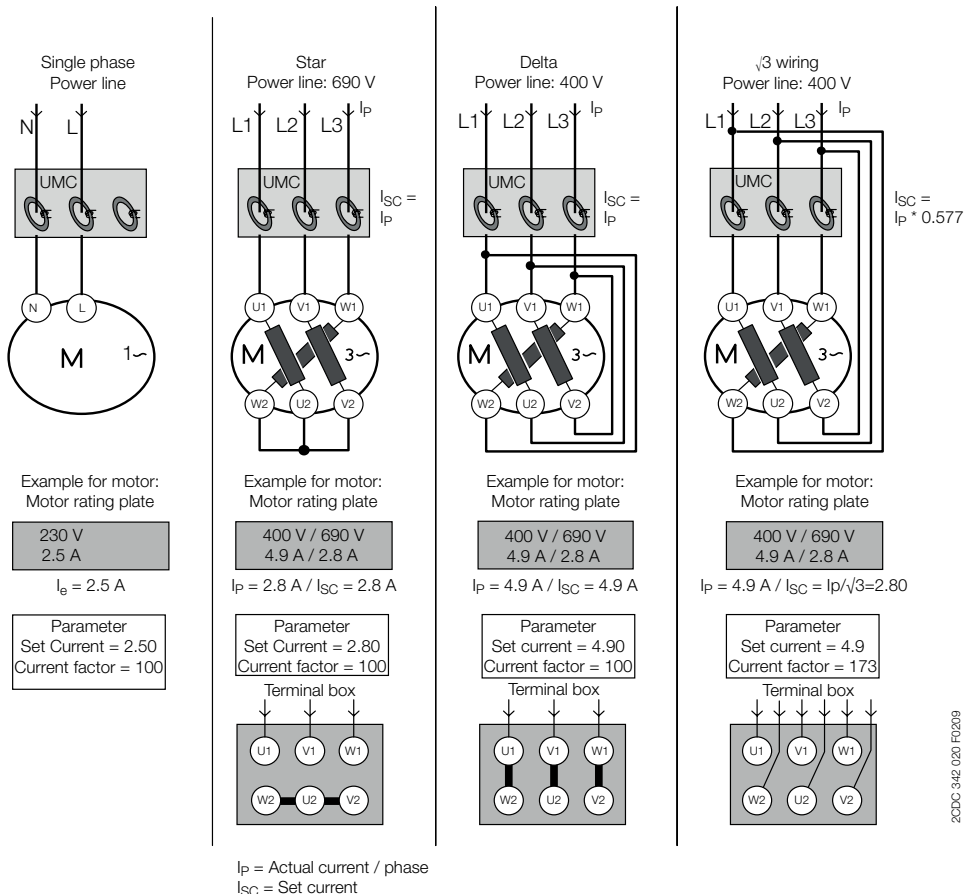

It is optional to feed N through the UMC if ground fault detection is disabled.

Related Parameters:

- Nominal current I_{e1}
- Current factor

Connecting External Current Transformers (CTs)

If the nominal motor current I_n is above 63 A an external current transformer (CT) must be used. The external CT transforms the primary current flow in a smaller secondary current according to the transmission ratio. This smaller current is then measured from the UMC100.3. With the parameter Current Factor the current transformer transmission ratio can be configured. So the UMC100.3 knows the actually flowing primary current which is then used for the internal processing. The current transformers CT4L/5L are available as accessories for the UMC100.3.



For the connection between CT and UMC use wires with a cross section of 2.5 mm² at a distance < 2 m. The burden of the CTs has to be below 60 mΩ. If the supervision of the phase order is active or a voltage module should be used:

- take care of the correct phase sequence and feed through direction of the main motor wires through the CT4L/5L
- take care of the correct phase sequence and feed through direction of the wires between CT4L/5L and UMC.

CT-type	Nominal current range of motor [A]	Max. current [A] (Accuracy 3%)	Current factor (Default = 1.0)	Secondary current at nominal primary current range [A]	Factor to be set in the UMC (e. g. via LCD panel)	Link kit ¹⁾
UMC100 CT built-in	0.24-63	630	1	-	100 (default)	-
CT4L185R/4	60-185	1480	46.2	1.3 - 4	4625	DT450/A185 -> AF145, AF185
CT4L310R/4	150-310	2480	77.5	1.94 - 4	7750	DT450/A300 -> AF210-AF300
CT5L500R/4	200-500	4000	125	1.6 - 4	12500	DT500AF460L-> AF400, AF460
CT5L850R/4	400-850	6800	212.5	1.88 - 4	21250	DT800AF750L -> AF580, AF750

¹⁾ Order data see catalogue

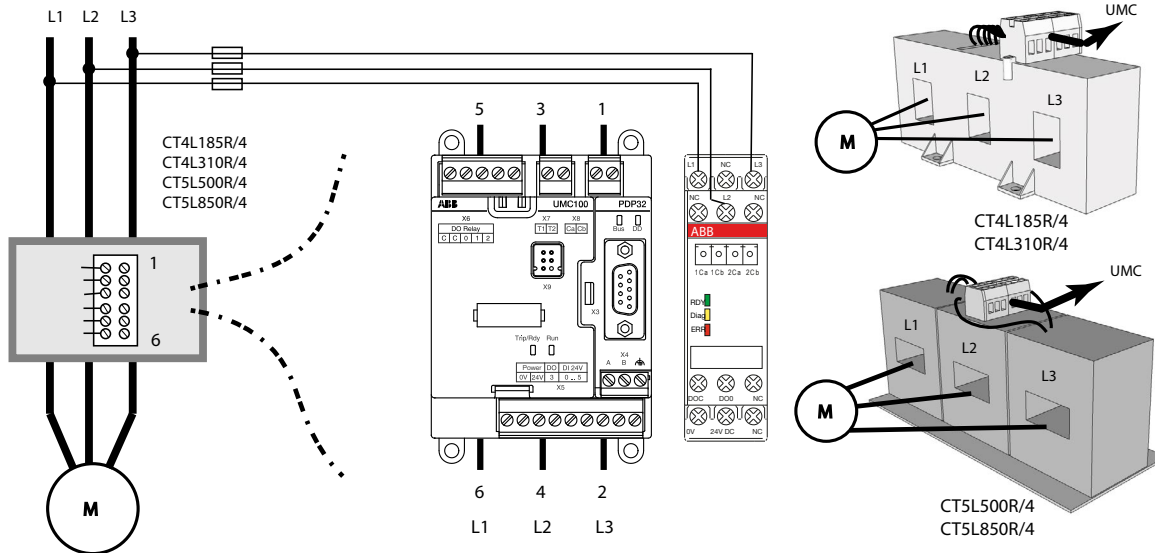

Wiring scheme when using ABB CT4L/5L current transformers



If current transformers of other suppliers are used the table above may serve as a calculation basis for the current factor.

Example: Type CT5L500R/4 means: Primary 500 A, secondary 4 A, current factor 125.
In the UMC the real motor current has to be set e. g. 500 A.



For high efficiency motors the start-up current can be $> 8 * I_e$.

In this case it might be necessary to use the next larger CT if the startup-current is above the max. current listed in the table above.

Examples:

- $I_e = 180$ A, startup-current $7 * I_e \rightarrow 1260$ A \rightarrow Use CT4L185R/4
- $I_e = 180$ A, startup-current $10 * I_e \rightarrow 1800$ A \rightarrow Use CT4L310R/4 in this case.

Operation Details for Motors with Small Set Currents

When using a UMC100.3 in an environment with very strong magnetic fields and a small set current at the same time, the current measurement can deviate a few percent from the real current. Therefore the displayed motor current is too high and an overload trip occurs too early.

Very strong magnetic fields can originate from a contactor directly mounted beside the UMC100.3, closely passing current links or stray fields caused by large transformers.



When observing the effect, the distance between the UMC100.3 and the contactor shall be increased to about 5 cm or the UMC100.3 turned by 90 degrees or the motor wires shall be looped through the UMC100.3 two to five times. When looping the motor wires multiple times, the parameter Current Factor must be adjusted according the number of loops. I.e. the parameter must be set to two if the wires are looped through the UMC100.3 two times. Two to five loops are supported. The displayed current and the current transmitted over the fieldbus are automatically corrected by the UMC100.3.

Please note that the adaptation of the current factor for $\sqrt{3}$ circuits and multiple loops through the UMC100.3 are not possible at the same time.



Via fieldbus also higher values than five e. g. six can be set.

The UMC100.3 ignores such values and creates a parameter fault. Values above 100 are possible and used in combination with external current transformers (see previous page).

Related parameters:

- Current Factor
- Nominal current 1 / 2

Connecting the UMC100-PAN LCD Panel

The UMC100-PAN LCD panel can be used for the following purposes:

- Configuration of the UMC100.3
- Control of the motor and fault reset
- Monitoring of all IO signals, motor current and maintenance counters
- Connecting a configuration laptop via USB interface

The operator panel UMC100-PAN is mainly designed for mounting it on the front panel of a motor feeder or in a switchgear cabinet. A door mounting kit is provided for this purpose.

The UMC100-PAN can also be plugged directly on the UMC100 itself

With the mounting kit the degree of protection is IP52.

With the mounting kit and the optional protection cap the degree of protection is IP54.

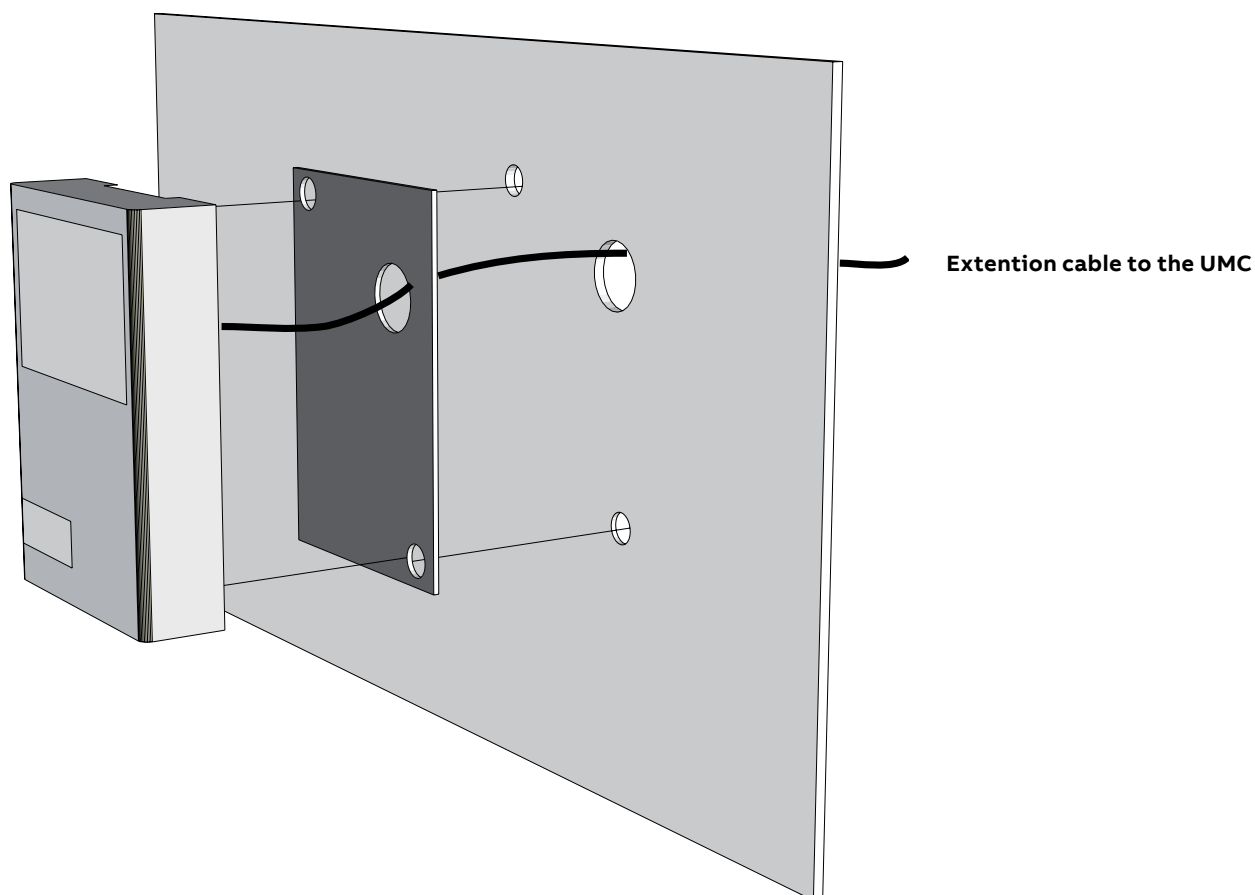

The UMC100-PAN is not compatible with the UMC22-PAN and cannot be used with the UMC22-FBP but only with UMC100.3.

The UMC100-PAN is backwards compatible with earlier versions.
In case of a replacement of the UMC with the new type it is not required to also replace the LCD panel.

Using the UMC100.3 in a PROFIBUS DP Network

PROFIBUS DP is at present one of the most common fieldbus for industrial applications worldwide and is standardised in IEC 61158 together with other fieldbus protocols. The PROFIBUS DP standard has defined different network topologies. The most commonly used one is the 'daisy chain' topology where one device is connected after the other.

PROFIBUS DP has evolved over time. The first services offered by PROFIBUS DP are the so-called V0 services. They define block parameterisation, configuration, cyclic data exchange and diagnosis information exchange. DP-V0 only allows the complete parameter set to be written in one block. The bus master sends the parameter block to the slave during powering up of the slave/device. Some control systems also allow sending the parameter block during normal operation.

Later the PROFIBUS DP-V1 specification introduced new acyclic read/write services within the context of the PROFIBUS DP-V1 expansions. These acyclic services are inserted into special telegrams during ongoing cyclical bus operation and thus ensure compatibility between PROFIBUS DP-V0 and PROFIBUS DP-V1. UMC100.3 is integrated in a Profibus DP network by using a PDP32 communication interface.

The diagram below shows the sketch of a PROFIBUS bus line with UMC100.3 devices. A detailed description about the PDP32 and different possibilities to use it is available in the PDP32 manual.

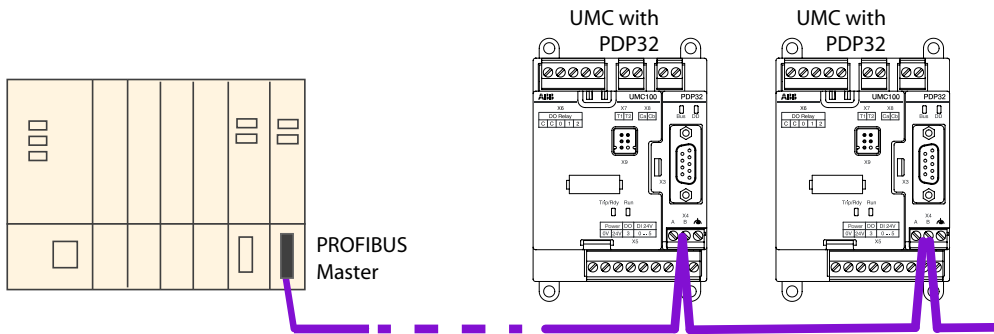

PROFIBUS Line with UMC100.3 and PDP32.

Use standard PROFIBUS cable for wiring. It is also possible to mount the PDP32 remote from the UMC. See PDP32 manual for more information. Instead of directly connecting the PROFIBUS cable to the PDP32 X4 terminals also DSUB-9 connectors can be used and connected to X3

Integration with the GSD File

Besides the physical connection of a device to a PROFIBUS line, the engineering of the whole PROFIBUS system in the PROFIBUS master is necessary. Every PLC (Programmable Logic Controller) or DCS (Distributed Control System), that can be used as PROFIBUS master, offers the possibility to configure and parameterise devices connected to the master. Electronic data sheets are used as a basis. In the PROFIBUS world these electronic data sheets are called GSD files. Within such a file all properties relevant for operation of the slave are described (e.g. supported baud rates, max. number of modules etc.).

The GSD file for PDP32.0 can be obtained from ABB's web site: <http://www.abb.com> > Product Guide > Low Voltage Products and Systems > Control Products > Motor Controllers > Universal Motor Controllers > Software

Integration with the Field Device Integration (FDI) technology

In addition to the option of integrating devices with GSD files more and more modern control systems support standardized configuration tools. FDI is the standard technology for the configuration of field devices in the process industry. For the UMC100.3 an FDI Device Package is available.



To create a customer-specific application, the FIM UMC Edition software must be used! Parameterization of the control and protection parameters can also only be carried out with the GSD file.

Using the UMC100.3 in a DeviceNet Network

DeviceNet is based on the Controller Area Network (CAN) technology and mostly used in the Americas. To integrate the UMC100 into a DeviceNet network use the DNP31 communication interface.

The figure below shows the sketch of a DeviceNet line with DNP31 and UMC100s. More details are available in the technical manual of the DNP31.

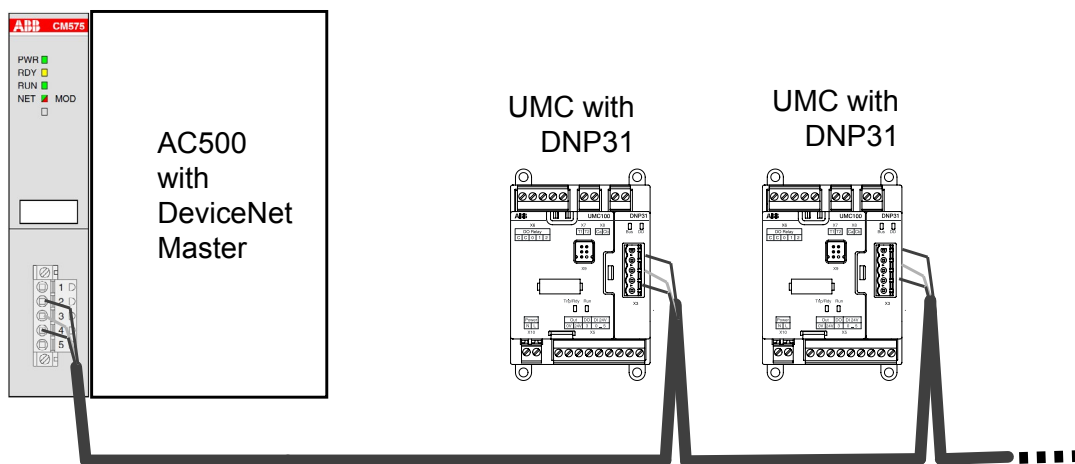

DeviceNET Line with UMC100.3 and DNP31. Use standard DeviceNet cable for wiring

Integration with the EDS File

Besides the physical connection of a device to a DeviceNet line, the integration and engineering of the devices in the DeviceNet master is necessary. An electronic data sheet is provided for the UMC100.3 for that purpose. In the DeviceNet world these electronic data sheets are called EDS files. Within these files all the properties relevant for operating the slave are described (e.g. supported baud rates, parameters, ...).



Configuration of the control and protection parameters of the UMC100.3 can be carried out using the EDS file. For creating a customer-specific application the FDI software tool can be used!

ESD file for UMC100.3 with DNP31 can be obtained from ABB's web site : <http://www.abb.com>

> Product Guide > Low Voltage Products and Systems > Control Products > Motor Controllers > Universal Motor Controllers > Software

Using the UMC100.3 in a MODBUS RTU Network

The MODICON Modbus® RTU protocol is a widely used network protocol based on the RS485 physical layer. It is provided in many PLCs that do not offer any other fieldbus. To integrate the UMC100.3 into a Modbus network, use the MRP31. The diagram below shows the sketch of a Modbus line with two MRP31, two UMC100s and available accessories. More details are available in the technical manual of MRP31.

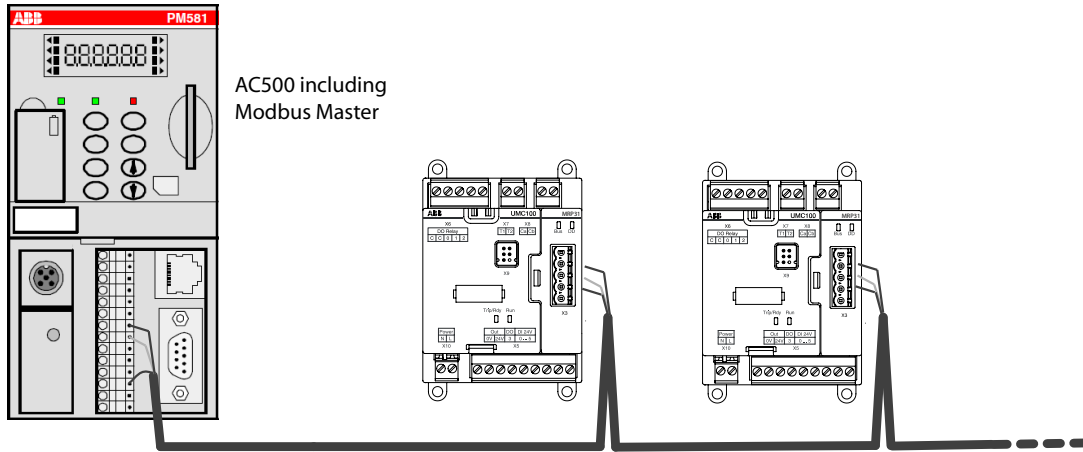

—
Modbus Line with MRP31 and UMC100.3. Use standard Modbus cable for wiring



There are no device description files defined by the Modbus standard. Therefore we recommend that you parameterize the UMC100.3 either using the UMC100-PAN or using a laptop with the FIM UMC Edition software.

Using the UMC100.3 in withdrawable applications

The withdrawable technique is often used in industries where the highest availability and shortest downtimes are required. In the event of an error in a drawer, the replacement with a spare drawer shall be made as fast as possible.

UMC100.3 has several unique features supporting its use in drawer systems:

- The separation of communication interface and UMC100.3

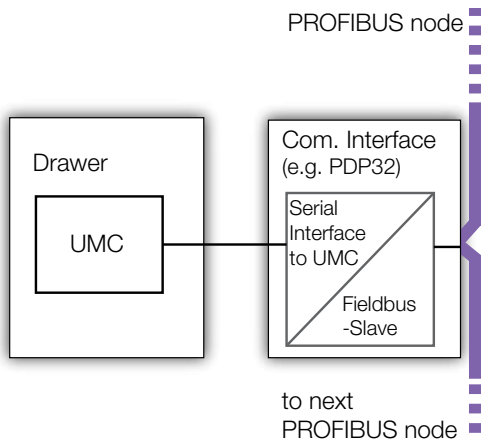

- In draw-out installations the UMC100.3 is usually mounted inside the drawer whereas the communication adapter is mounted in the cable chamber. This ensures that no droplines are required but a straight bus line can be implemented. A very stable bus communication even at high baud rates is the result!
- In the event of a drawer replacement the communication adapter stays active and sends a diagnosis message to the control system that the UMC100.3 is missing. Even more important - the fieldbus address is stored in the communication adapter. If a new UMC100 is connected, the old bus address is automatically used. There is no need for setting a new address! See parameter Address Check for additional details.

All necessary auxiliaries required for the installation are available. See the diagram below on how to use a PDP32.0, MRP31.0 or DNP31.0 in a drawer system. The example shows the EIU32.0 EtherNet/IP™ communication interface.

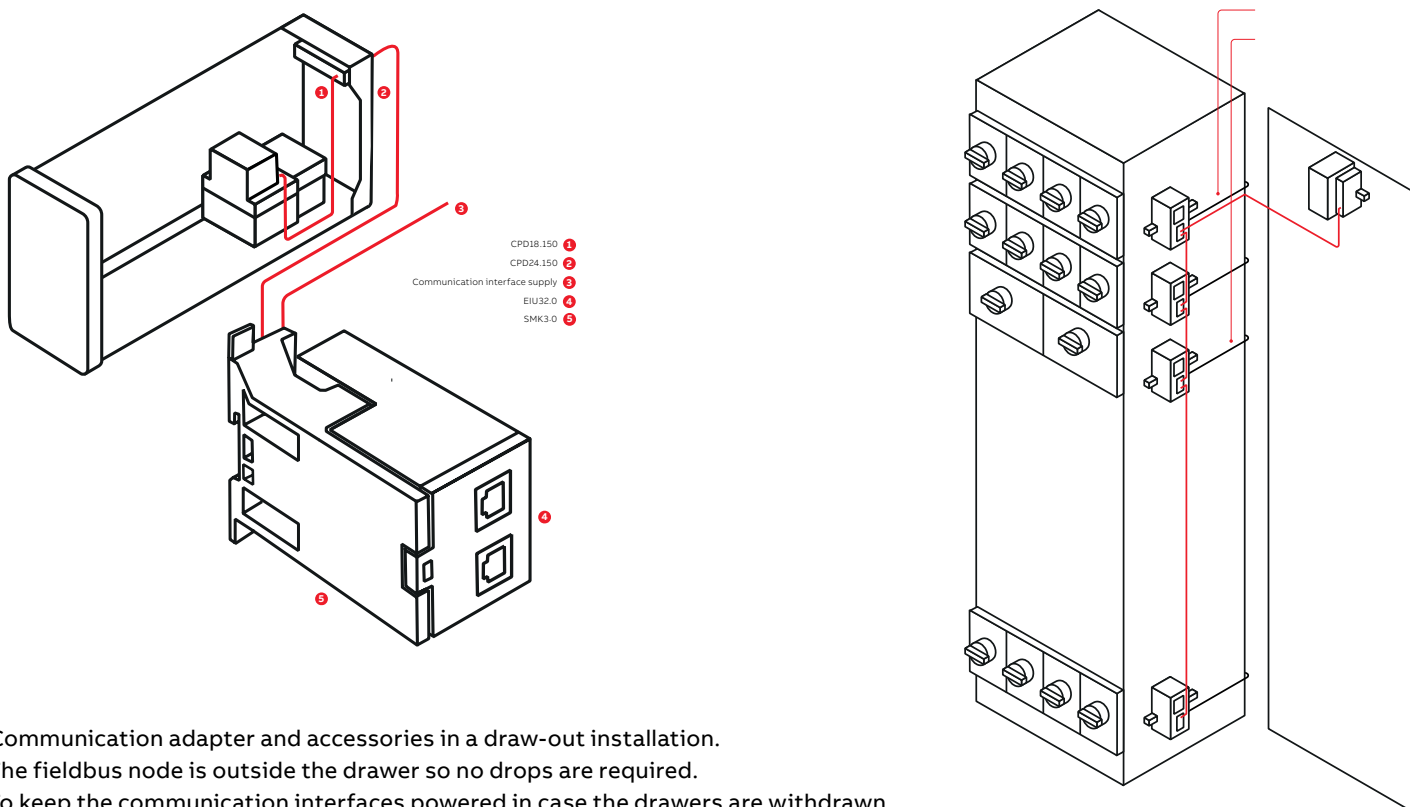

Communication adapter and accessories in a draw-out installation. The fieldbus node is outside the drawer so no drops are required. To keep the communication interfaces powered in case the drawers are withdrawn they must be powered separately (not shown here).

3 Commissioning

This chapter provides an overview of the required commissioning steps. For details about the single steps please consult the related chapters.



Consider the special requirements for ATEX, indicated in chapter 10.

Commissioning Steps

To commission the UMC100.3, proceed as follows:

A) Wiring

Wiring and supply voltage connection:

Hard wire with switch apparatus and other components acc. to the application requirements.

Connection of contactors: Use spark suppression. For larger contactors also interface relays to maintain a good service life of the UMC100.3 internal relays can be used.

Motor wiring:

Check the wiring of the motor to ensure correct setting of I_e for perfect motor protection. When using UMC100.3 with motors of nominal currents < 1 A please read section "Operation Details for Motors with Small Set Currents".

If the nominal motor current is above 63 A read chapter 2, section "Connecting External Current Transformers (CTs)" on how to use the UMC100.3 with external current transformers.

If an IO expansion module is used connect the UMC100.3 with the IO module and hard wire the inputs of the expansion module acc. to the application requirements.

B) Switching on the power supply

Switch on the supply voltage of the UMC100.3. In the fault-free state, the green UMC100.3 LEDs should light up.

- LEDs on the UMC100.3:
 - Red / Green (trip/ready) Green
 - Yellow (motor running) Off
- LEDs on the communication interface:
 - Normally the LED named DD should light up in green.
 - If no cyclic bus master is active the LED named Bus is flashing.
 - See the technical description of the use communication adapter for more information.

Continue with Step C) if fieldbus communication is required or continue with step D) to start the configuration.

In case of an error use the LEDs or the UMC100-PAN to find out the fault cause (see chapter "9 Error Handling").

C) Setting the fieldbus node address

Before connecting the UMC100.3 to a fieldbus network (e.g. PROFIBUS) set the fieldbus address using UMC100-PAN.

That means the slave address is directly adjusted and stored in the UMC100.3.

To change the bus address, press Menu, select Communication and then Bus Address.

Adjust the address within the limits defined by the fieldbus type (for PROFIBUS e.g. 2 to 125).

D) Start configuring the UMC100.3 via LCD panel, laptop or control system

The following parameters need to be adjusted

- Motor management related parameters e.g. the control function (see chapter "5 Configuring the Motor Management Functions")
- Parameters defining how to start and stop the motor from the different control places (see chapter "5 Configuring the Motor Management Functions -> Starting and Stopping the Motor").
- Parameters related to the motor and its protection functions (see chapter 4 "Configuring the Motor Protection Functions").

- Parameters related to the fieldbus communication interface
(see chapter 6 "Configuring the Communication Interfaces")
- Other settings such as the panel language or the usage of an expansion module.
- Select the required configuration mode for the UMC100.3

The UMC100.3 can be configured in different ways depending on your system setup:

Configuration via LCD panel

The device address has to be configured via LCD panel. It is possible to adjust all other protection and control parameters of the UMC100.3 using the panel. The configuration via LCD panel is good for stand-alone applications (without bus) and when no laptop for parameterisation is in use.

The configuration via LCD panel can be password-protected to prevent unintentional parameter changes.

Configuration from within the control system

Device description files allow the integration and configuration of a device into the fieldbus master. For PROFIBUS this is a GSD file, Profinet uses GSDML, DeviceNet and EtherNet/IP use EDS files.

The UMC100.3 can be configured using these files. A significant benefit of this method is that the configuration is stored centrally in the control system and can be downloaded again in the event of a replacement.

Configuration via Laptop

The configuration via laptop option is a convenient way to parameterise and monitor the UMC100.3.

The FDT/DTM based configuration tool provides full access to all data available in the UMC100.3.

The following functions are available:

- Online and offline configuration and parameterisation of the UMC100.3
- Monitoring and diagnosis of the UMC100.3 during operation
- Function block-based programming of a user-specific application using the Customer Application Editor

Connect the service laptop with a standard micro USB cable to the UMC100-PAN for configuration of a single UMC100.3. The software detects the right communication port and scans for a connected device.

If several UMC100s are connected via PROFIBUS, the UTP22 communication adapter can be used. This adapter connects a laptop to the PROFIBUS line and allows central configuration and monitoring of all UMC100.3 connected to this line. This is recommended for larger PROFIBUS installations.

FIM UMC Edition is based on the FDI standard. A limited online version for testing is also available.

Please download the information for this software and how to install it.

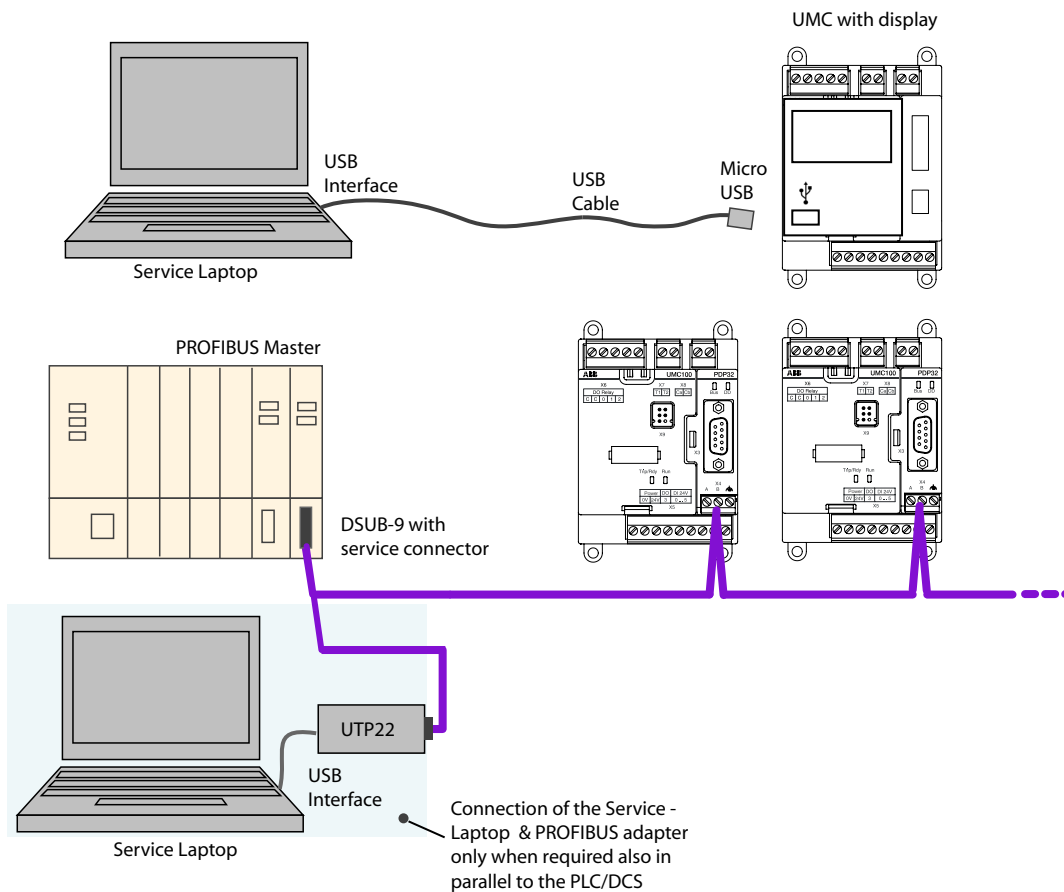

—
Connection of a service laptop using a USB cable connected with the UMC100 LCD panel (point-to-point) or UTP22-FBP (for a whole PROFIBUS line)

Test Position

It is possible to configure a multifunction input (DI0, DI1 or DI2) to inform the UMC that the feeder is in test position. If the digital input signals the test position, the feeder's main circuit must be isolated from the motor supply - but the control voltage of the UMC must be connected.

During active test position the function of the feeder and its integration into the control system can be tested. I.e. the motor can be started but the UMC does not trip because of a missing checkback.

Use the parameters Multifunction 0,1,2 to enable this function.



If the feeder is in test position the UMC has disabled the checkback supervision and the other motor current/voltage related protection functions. Therefore the test position must be only active for commissioning purposes.

4 Configuring the Motor Protection Functions

General Information

The UMC provides comprehensive motor protection including phase failure detection, adjustable motor protection for stalled motors during startup or normal operation, configurable current limits to generate trips or warnings and many more.

The different protection and monitoring functions generate warning signals, trip signals and measured or calculated process values. All these data are available to the user to either display them on the LCD panel, transfer them to the control system or process them in a custom specific application.

The UMC100.3 can be used with or without an additional voltage module or analog input module. The protection functions available without a voltage module are described in section "EOL and Current based Protection Functions". The protection functions that require a voltage module are described in section "Voltage and Power Protection Functions". The Voltage Dip function which can be used with or without a voltage module is described in section "Voltage Dips, Load Shedding". The supervision functions available with the analog input module are described in section "RTD based Temperature Supervision and Analog Inputs".

Automatic Reset of Protection Faults

The setting of the "Fault autoreset" parameter determines how the UMC manages protection trips.

- **Off** (the default setting)
 - A protection trip must be acknowledged from the user. This can be done via LCD panel, fieldbus or the multifunction inputs DI0-DI2 if configured.
- **On**
 - A protection trip is automatically acknowledged without intervention of a human operator if the trip condition has gone.

EOL and Current based Protection Functions

In this section you find information on how to configure the different motor current based protection functions of the UMC.

The following topics are covered:

Function and parameters of the electronic overload protection, the thermal memory and points to consider if the motor is started cyclically (e.g. S3 motor operation mode)

- Long start, locked rotor protection during motor start
- Overcurrent and undercurrent protection during normal operation
- Imbalance protection
- Phase loss protection
- Phase sequence
- Thermistor motor protection
- Earth fault protection with auxiliary device CEM11-FBP or internally calculated

The following process values are available:

Process Value	Explanation	Data range
Motor Current	The average current of the three phases and single phase currents	0...800 % of I_e
Motor Current	The average current of the three phases	In user selected unit (A, mA ...)
Earth Fault Current	Calculated earth fault current	in % of I_e
Thermal Load	Thermal load of the motor	0...100%. 100% is the trip level.
Current Imbalance	Imbalance of the motor current in the three phases	0...100%
Time to Trip	Time until the EOL trips the motor	0 ... 6553 s (6553 s means an infinite trip time)
Time to Cool	Time until the motor can be restarted	0 ... 6553 s
PTC Resistance	Value measured from the PTC input in ohms.	0 ... 4800 Ω
Line Frequency	Mains frequency	45 ... 65 Hz

Protection functions can be either on or off. If switched on, they can trigger a protection trip or a warning (excluding the thermal overload which is always active and triggers a trip). For some functions an optional delay can be specified. Some protection functions are only active after motor start-up while others are active during motor start.

Below is an overview of the available protection functions and when they are active. For details see the following sections.

Current-based Protection Functions	When active	Available Options: Trip/Warning/Off	Automatic Fault Reset Possible	Delay
Electronic Overload	Always	Trip	Yes	-
Electronic Overload Prewarning	Always	Warning	-	-
Locked Rotor	During motor start	Trip / OFF (800 %)	-	x
High Current	After motor start	Trip/Warning/OFF separate warning and trip levels optional delay	-	x
Low Current	After motor start	Trip/Warning/OFF separate warning and trip levels optional delay	-	x
Imbalance	Always (Motor current > 25 % of I_e and all three phases available)	Trip/Warning/OFF (OFF = only together with phase loss) separate warning and trip levels	Yes	Depending on trip class 2 / 3.5 / 6.5 / 9.5 / 12.5 s
Phase Loss Protection	Always (Motor current > 25 % of I_e)	Trip, Off	-	Depending on trip class 1.5 / 3 / 6 / 9 / 12 s
PTC Protection	Always	Trip, Warning, Off	Yes after cooling (excluding PTC wire break and short circuit)	-
Earth Fault Protection	Always After start-up	Trip, Warning, Off (255 %) separate warning and trip levels	-	x
Load Shedding / Voltage Dip	Always Not in test position	See subsection Voltage Dip	-	
Phase Sequence Protection	Always	Trip, Warning, OFF	-	Depending on trip class 1.5 / 3 / 6 / 9 / 12 s



The motor start-up period ends when the motor current drops to 135 % of I_e or if the class time (i.e. Class 5 -> 1.5 s, Class 10 -> 3 s, class 20 -> 6 s, class 30 -> 9 s, class 40 -> 12 s) is over. The class time begins with the start command.

The motor-related and protection-related parameters shall be set according to the motor manufacturer's data sheet. Other parameters of the UMC shall be carefully selected based on the process and the system requirements.

Electronic Overload Protection

The UMC protects single - and three-phase AC motors in compliance with IEC 60947-4-1. The tripping class can be set to class 5, 10, 20, 30 or 40. The advanced thermal motor model considers both the copper and iron parts of the motor thus providing the best protection of the motor.

Before an overload trip actually happens, a pre-warning can be generated. During high overload situations the prewarning might be raised just a few seconds before the actual trip happens.

The presently used thermal capacity (0...100 %) of the motor is available to the user and thus a prediction of the time to trip for the current load situation. If the motor is switched off the time to trip shows 6553 sec (never trips). If the motor is running the predicted trip time is updated regularly. The smaller the value the earlier the trip happens.

After an overload trip, the remaining cooling down time (=time to restart) is calculated regularly and also available to the user. The motor can be restarted if the cooling time is 0 sec.

Block Diagram:

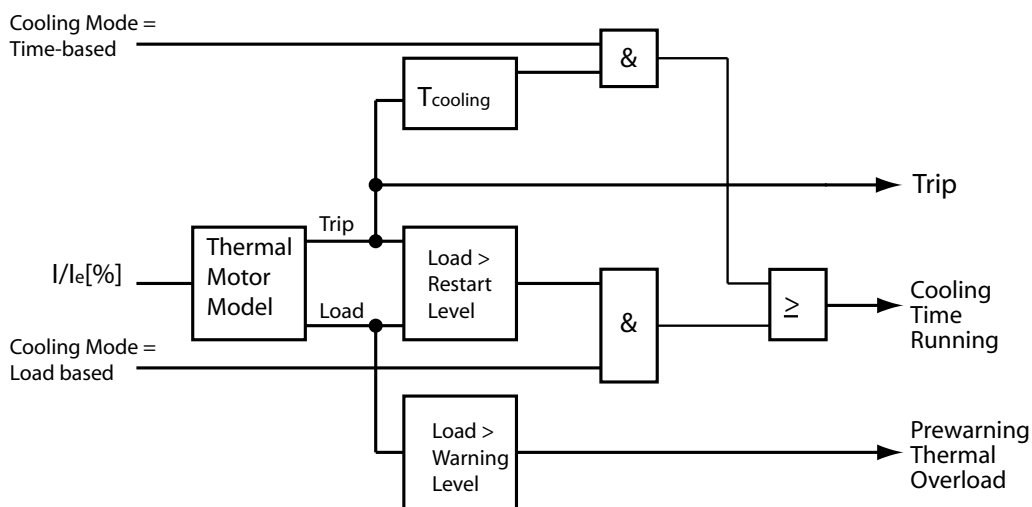

Signal flow of the thermal overload protection

The thermal information of the motor is cyclically stored (thermal memory) 1). After a thermal overload trip the motor must cool down before it can be started again. There are two options to define the necessary duration of the cooling time.

- Fixed cooling time: The user has to specify a fixed duration e.g. 15 minutes. After a thermal overload trip a further motor start is inhibited for that time. The time that has to be adjusted depends on: Motor size, motor with or without ventilation, the environment temperature etc. Considering these points the appropriate cooling time can be estimated.

Some examples of motor cooling time constants (t.c.) (motor standstill) can help:

Size	1 kW - 1 pole	5 kW -1 pole	5 kW - 2 pole	20 kW - 2 pole	20 kW - 3 pole	100 kW - 3 pole
c.t.	10 min	15 min	20 min	30 min	40 min	70 min

- Thermal capacity based cooling: The user specifies to which level (e.g. 60%) the thermal load level must drop before a motor start is possible again.

¹⁾ If the UMC was switched off while the cooling time was running and the power down time was shorter than 20 min, the UMC restarts the cooling timer with the remaining cooling time. Otherwise the cooling time is set to zero.

Example of trip class selection:

Select the trip class so that the motor is thermally protected, even when the rotor is stalled. This means that the tripping curve of a cold motor has to be below the coordination point I_a/I_e and t_E whereas I_a is the actual current, I_e is the nominal current of the motor and t_E is the maximal heating time as defined by the motor manufacturer. Example: Motor with enhanced safety has the data:

- Power = 7.5 kW
- Relation $I_a/I_e = 7.4$
- Heating time $t_E = 11$ s

The following diagram shows the tripping time for cold motors at symmetric load:

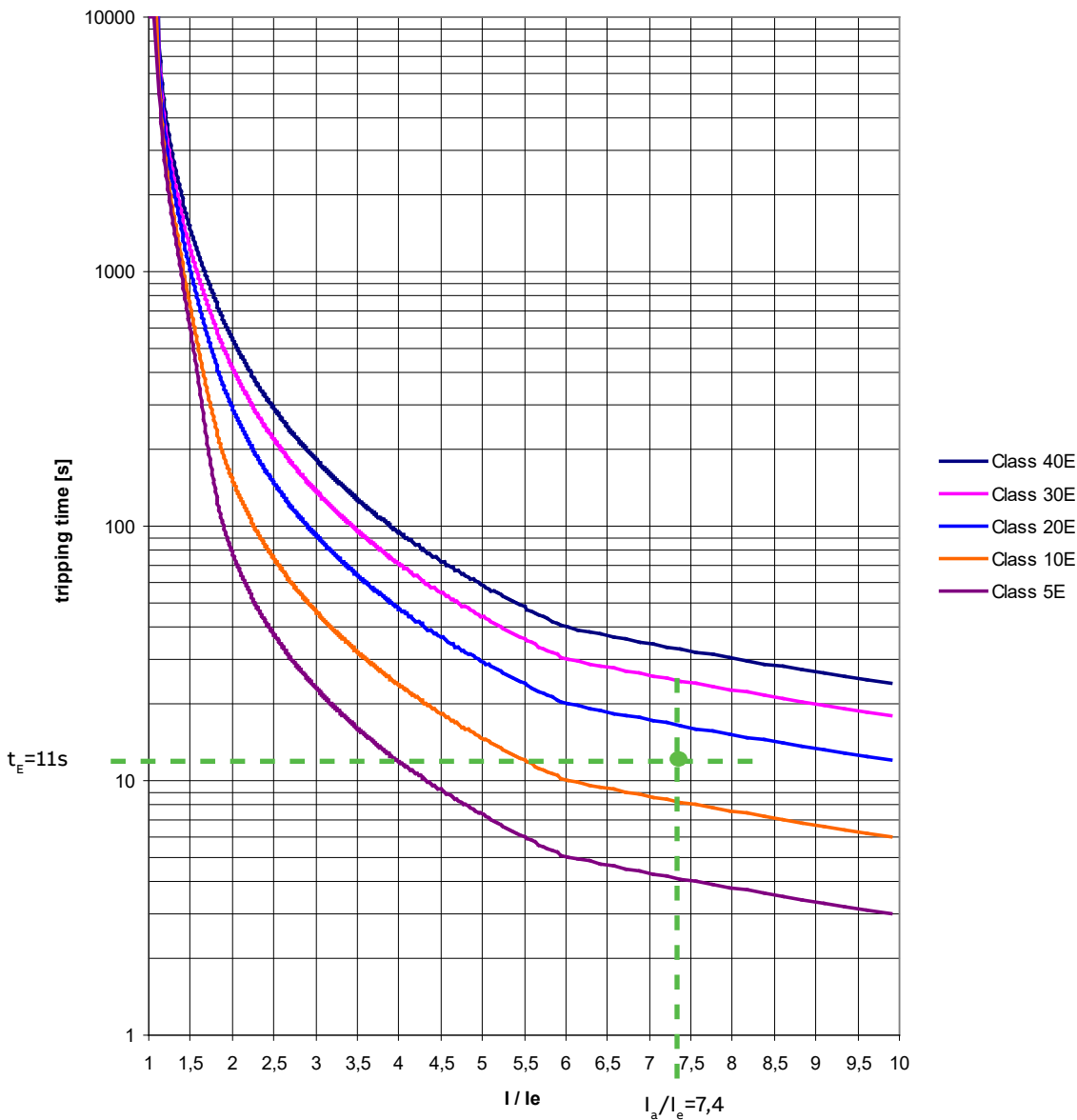
**Example for the trip class selection for a given motor**

The trip classes 5 and 10 are allowed because the appropriate times (3 s, 7 s) are below the time t_E of the motor (including the tolerance 10% of the UMC).

Cyclic motor operation modes

Some applications require periodic start/operation/stop cycles. Setting up such applications requires care when selecting the cooling down times or defining the shortest possible start period. In the next diagram three successive start cycles are displayed. In each cycle the motor starts at 700% I_e . This high load lasts for about 7 seconds. Then the current goes back to I_e within 6 seconds and stays at 100% I_e for about 180 seconds. At T1 the motor is switched off and cools down for 200 seconds (cooling time is set to 200 s). After the cooling time is over the next start takes place at T2. During this cycle the motor also cools down for 200 s but the calculated thermal motor load q is already above 40%. The third start at T4 leads - as expected - to a thermal overload trip



For cyclic operation modes it is important to keep the cycles long enough to allow the motor to cool down sufficiently. For cyclic start patterns it is better to select the cooling mode option "Restart Level" which allows a restart based on the thermal load level. In the case shown below the third start would then be allowed at the earliest at T5 for the given ϑ_R .

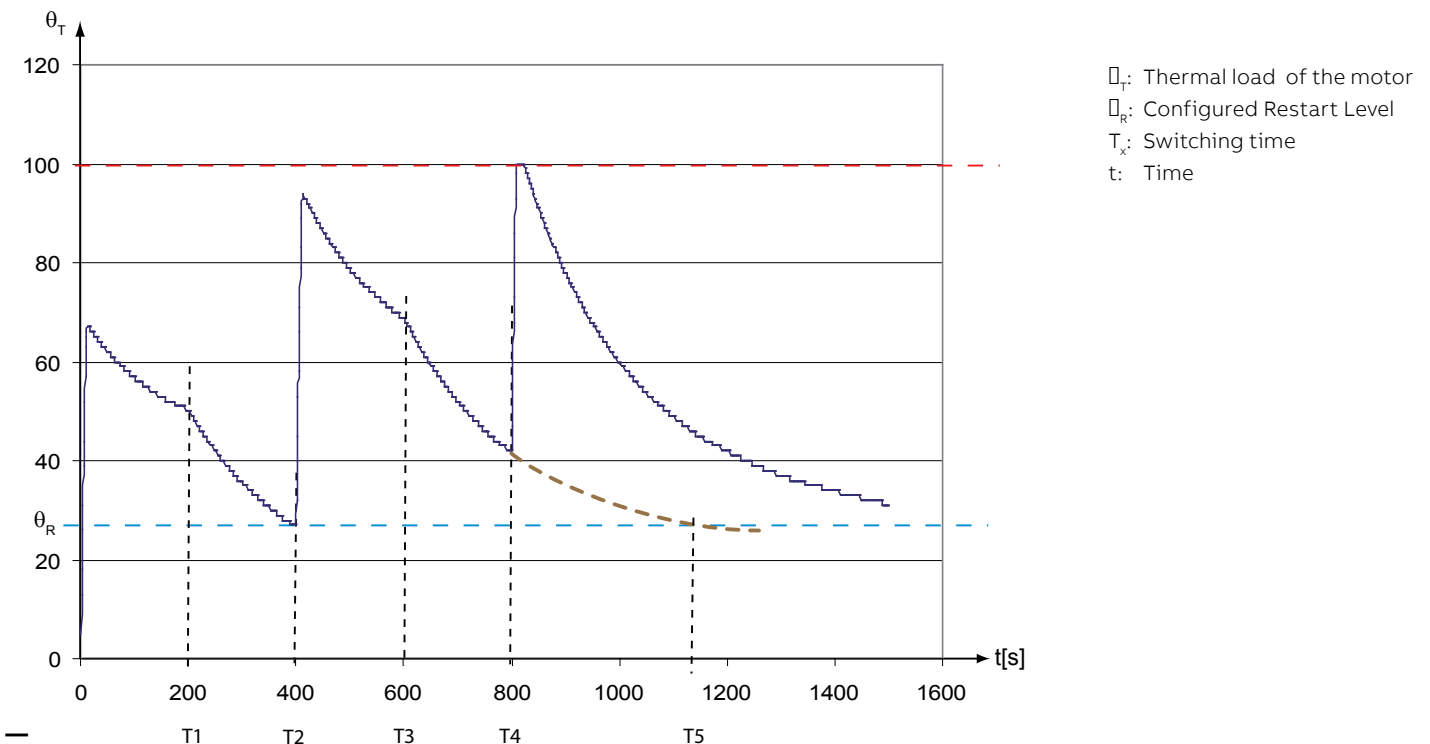

Trend of the calculated motor temperature after several starts.

The motor trips after the third start because the motor was started too frequently in the given time

Relevant Parameters:

- Trip Class
- Set Current I_{e1} and optionally I_{e2}
- Current Factor
- Cooling Mode
- Cooling Time
- Restart Level
- Thermal load Pre-Warning level
- Fault autoreset

Long Start, Locked Rotor Protection

This function detects a long start situation which is caused from a locked rotor for example. The function creates a trip if the motor current continuously exceeds a threshold for a configurable period of time. Blocking of a motor can occur due to excessive loading of the motor or due to process or mechanical jam. The early detection and tripping of the motor protects the driven mechanical system by further damage and the motor from thermal stress. This function can only trigger a trip. Both the maximum allowed current and the delay time until the trip occurs can be adjusted.

Block diagram:

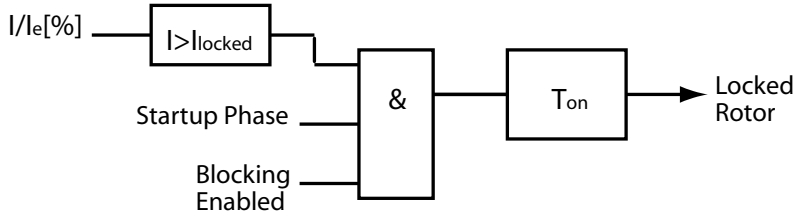

Signal flow of the locked rotor protection function

To adjust the blocking current threshold correctly proceed as follows:

- Take the highest inrush current value during a normal start. This value is displayed on the UMC100-PAN.
- Add a safety factor depending on how much your start-up load might vary.
- Set the blocking delay to a value that is shorter than the trip time resulting from the thermal overload trip at the given current.
- This protection function only works during the motor start-up period
- The motor start-up period ends when the motor current drops to 135 % of I_e or if the class time (i.e. Class 5 -> 1.5 s, Class 10 -> 3 s, class 20 -> 6 s, class 30 -> 9 s, class 40 -> 12 s) is over.
- The class time begins with the start command
- After the start-up phase the locked rotor protection is done by "high current protection"

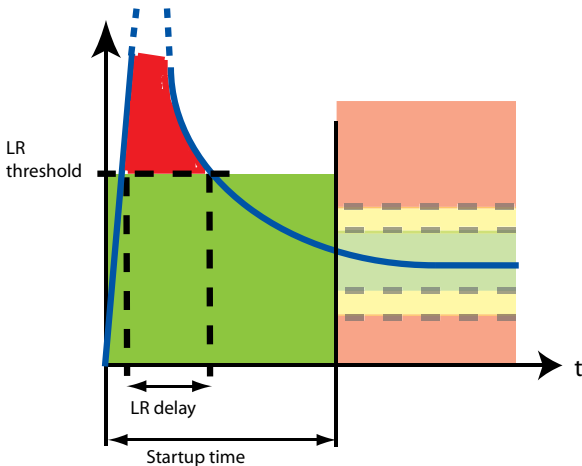

Startup phase of a motor:

If the motor current does not fall below the LR threshold within the configured LR delay time a locked rotor trip is triggered.

Relevant Parameters:

- Locked Rotor Level
- Locked Rotor Delay

High Current Protection

This function is useful to protect the driven mechanical system from jams and excessive overloads caused by the equipment or the process. The high-current function signals a warning when the motor current exceeds a set threshold for a configurable period of time, after the motor start-up. The high current function creates a trip when the current continuously exceeds a separately set threshold for a set period of time, after the motor start-up.

Block diagram:

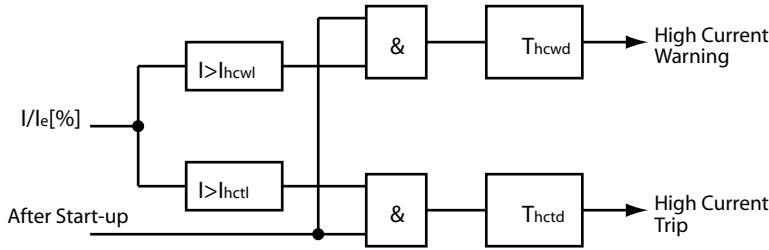

Signal flow of the high current protection function.

Example:

The start-up phase ended at T1. At T2 the current increases above the high current warning level I_{h_cwl} for a period longer than the high current warning delay time t_{h_cwd} . Therefore the high current warning signal is set. At T3 the current also increases above the high current trip level I_{h_ctl} but only for a period shorter than the specified high current trip delay time t_{h_ctd} . Then at T4 the current rises again above the trip level and stays there long enough to trigger an overcurrent trip that finally stops the motor.

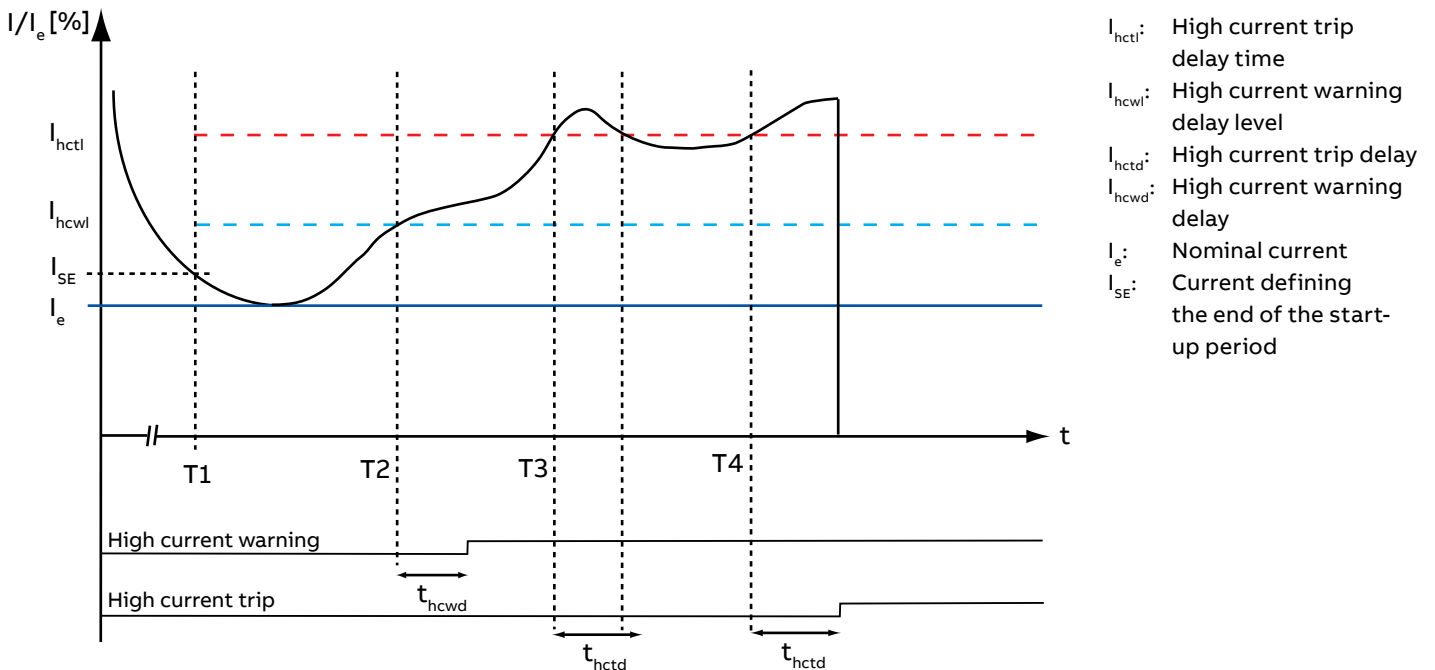

Trend diagram of the motor current over time

It shows the function of the high current protection function with the related parameters.

Relevant Parameters:

- High Current Trip Level
- High Current Trip Delay
- High Current Warning Level
- High Current Warning Delay

Low Current Protection

The low current function is triggered when the motor current falls below a desired level. The function detects loss of suction for pumps, broken belt for conveyors, loss of airflow for fans, broken tools for machines etc. Such states do not harm the motor but early diagnosis helps to minimise the extent of damage to the mechanical installation and subsequent loss of production. The motors on underload draw mainly the magnetising current and a small load current to overcome frictional losses. Therefore, the other reason to isolate the motors on underload is to reduce the reactive load on the power system network. The low current function signals a warning when the motor current falls below the warning level for a configurable period of time, after motor start-up. The low current function creates a trip when the motor current falls below the trip level for a configurable period of time, after motor start-up.

Block diagram:

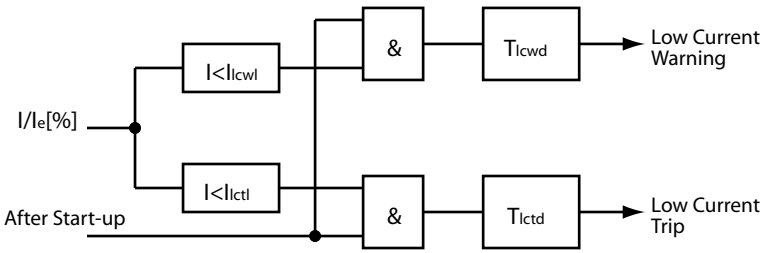

Signal flow of the low current protection function.

Example:

The diagram above shows an underload situation of the motor after the startup time is over (T1).

At T2 the motor current falls below the undercurrent warning limit I_{ucwI} .

After the undercurrent warning delay time t_{ucwd} an undercurrent warning is set. Then at T3 the current also falls under the undercurrent trip level I_{uctI} but only for a period shorter than the specified undercurrent trip delay time t_{uctd} . Therefore no trip happens.

At T4 the current falls again under the low current level and stays there. Therefore a trip is released and the motor stopped.

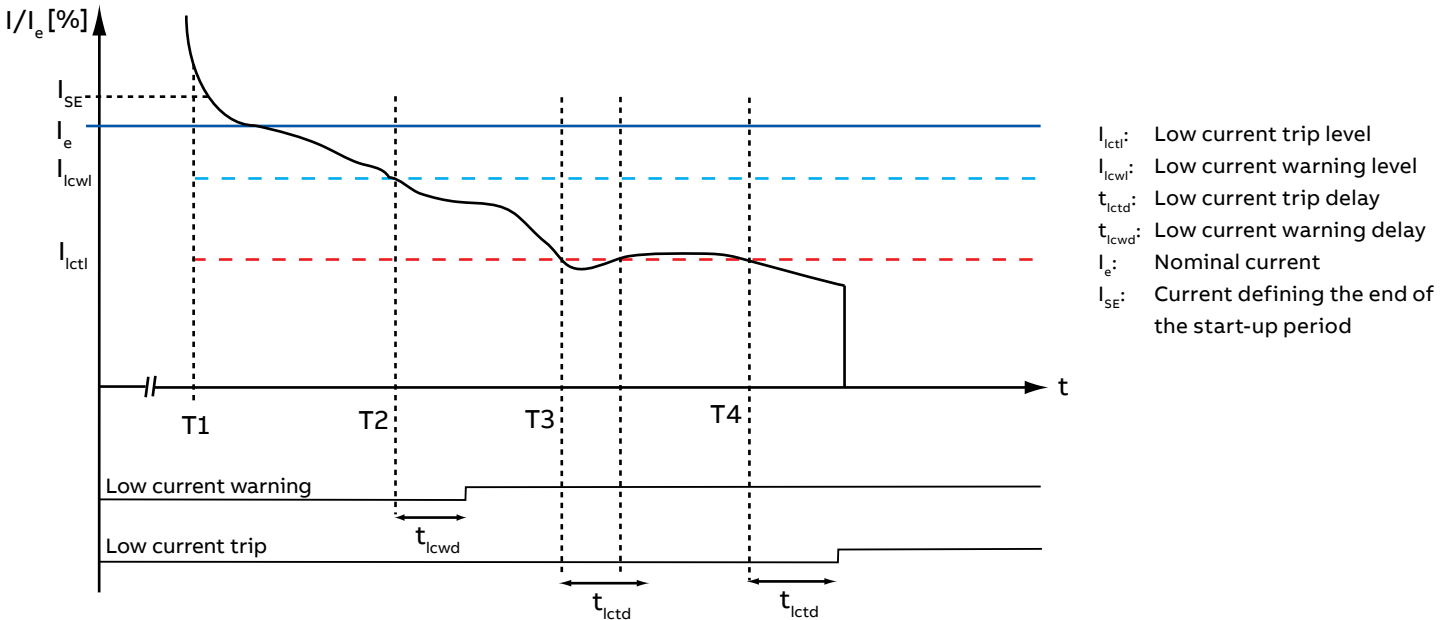

Trend diagram of the motor current over time

It shows the function of the low current protection function with the related parameters.

Relevant Parameters

- Undercurrent Trip Level
- Undercurrent Warning Level
- Undercurrent Trip Delay
- Undercurrent Warning Delay

Phase Loss Protection (Current)

This function protects motors against the extreme situation where a complete phase is lost. An undetected phase loss can cause motor damage because of the sudden rise of current in the two remaining phases. Thus the thermal overload protection performs an accelerated trip during phase loss. This function is based on the motor current and detects a phase loss while the motor is running.

The following table shows the tripping times in case of phase loss for the different trip classes.

Trip class	5	10	20	30	40
Tripping time [s]	1.5	3	6	9	12

Relevant Parameters:

- Phase Loss Protection

Phase Imbalance Protection (Current)

The phase imbalance protection protects the motor against a smaller imbalance between the different phases.



The phase imbalance trip level must be carefully adjusted to protect the motor windings against overheating. Take care of rules or guidelines possibly provided by the motor manufacturer.

Function:

The current imbalance function signals a warning if the ratio between the lowest and the highest phase current in percent is above the configured warn level.

- Formula: Phase imbalance = $100 \cdot (1 - I_{\min} / I_{\max})$

The current imbalance function signals a fault if the ratio between the lowest and the highest phase current is above the configured trip level. The trip delay depends on the trip class setting and is shown in the table below. This function is only active if the average current in the three phases is above > 25% of the nominal current I_e . In case of extreme imbalance value a phase loss might be signalled instead.

Block diagram:

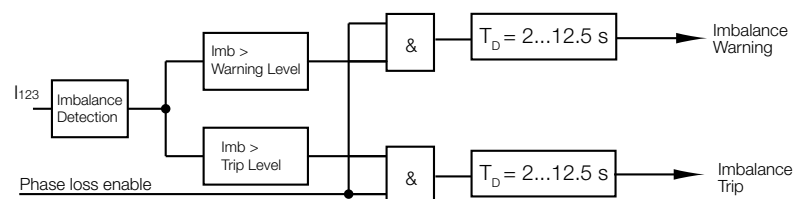

Signalflow of the phase imbalance function

Trip class	5	10	20	30	40
T_D	2	3.5	6.5	9.5	12.5

Relevant Parameters:

- Curr I_{mb} Trip Level
- Curr I_{mb} Warn Level

Phase Sequence Protection

Enable this protection function to prevent connected equipment from a wrong rotation direction e.g. when driving a crusher or conveyor. If this protection function is active the motor wires must have a defined order which is from left to right. The correct order is printed on the UMC100.3 housing. Take care that contactors are mounted after the UMC to ensure the phase sequence is not changed by switching the contactors (e.g. REV starter). Phase sequence protection is not available in single phase operation mode.



If a voltage module VI15x is present a wrong phase sequence is also detected if the motor is not running.



If no voltage module VI15x is present a wrong phase sequence is detected after the startup of the motor. In case of a wrong phase sequence the motor will trip after the class time.
(Class 5 -> 1.5 s, Class 10 -> 3 s, class 20 -> 6 s, class 30 -> 9 s, class 40 -> 12 s)



The correct phase sequence is L1 / L2 / L3. With the parameter "Phase Reversal" this can be changed to L3 / L2 / L1. In case a voltage module is present, this parameter must not be set!

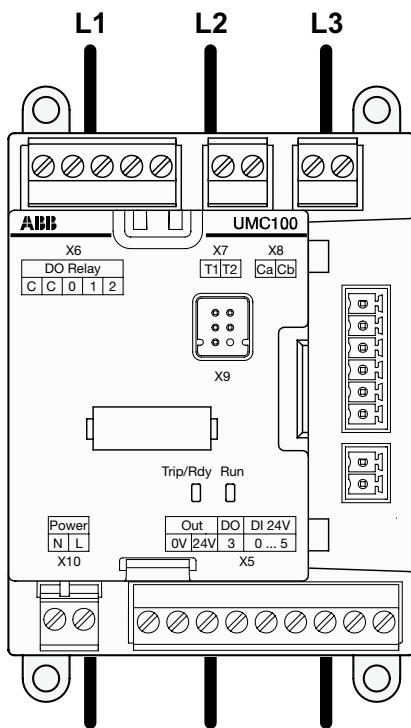

If the phase sequence supervision is active the phases must be fed through the UMC in the shown order

Relevant Parameters:

- Check phase sequence
- Phase reversal
- Motor current is > 23% of I_e

Earth Fault Protection

The earth fault protection function protects the motor and the network against ground current flow. Earth faults are mainly caused due to ageing of the insulation, deterioration of insulation due to sustained or cyclic overloading, moisture or conductive dust. The monitoring of the earth fault is carried out with the help of the auxiliary device CEM11 or based on an UMC100.3 internal calculation of the ground fault current. Detection of ground faults can be used to interrupt the motor to prevent further damage, or to alert the maintenance personnel to perform timely maintenance.

Protection based on external earth fault detection device CEM11

The CEM11 device monitors if the sum of the three phase currents is zero. It is using a current transformer where all 3 phases are fed through. The signalling output of the CEM11 can be connected to one of the multifunction inputs of the UMC.

The earth fault signal can be optionally delayed. It is also possible to suppress the earth fault during the motor start-up phase.



- CEM11 can be used in all types of networks (grounded or ungrounded)
- Can be used also in networks with higher impedance to ground. Also small ground fault currents can be detected

Block diagram:

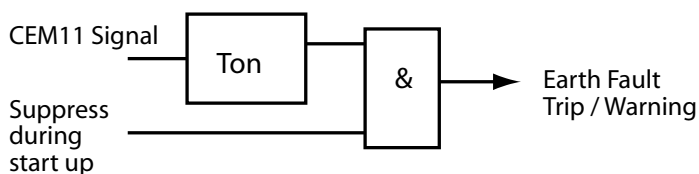

Signal flow of the earth fault protection function

Sample Circuit Diagram: To use CEM11 with the UMC proceed as follows:

1. Select the CEM11 model that suits your application needs. There are four different models available with feed-through holes from 35 mm to 120 mm.
2. Connect the CEM11 to one of the multifunction inputs DI0, DI1 or DI2 and 24V DC supply.
3. Configure the corresponding multifunction input as earth fault input. You can select if the earth fault supervision shall be suppressed during motor start or not.
4. Optionally a time can be configured to delay the creation of a fault or warning. It is adjustable from 0.1 to 25.5 s.
5. Configure the threshold when an earth fault should be signalled. The threshold can be set directly at the earth fault monitor (CEM11) itself. See the CEM11 technical manual for further details.

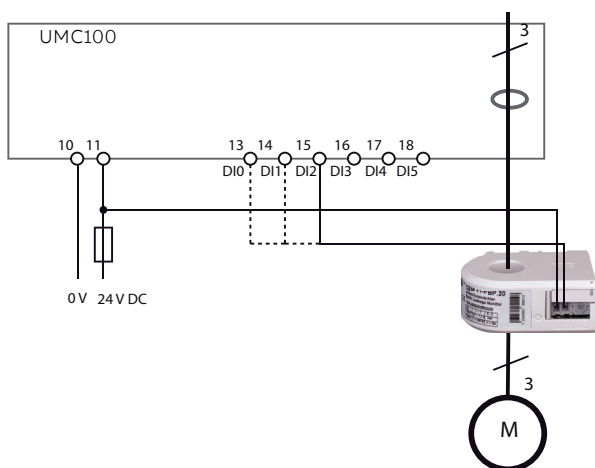

Relevant Parameters CEM11:

- Multifunction Delay Time
- Multifunction Inputs 0,1, or 2

Protection based on internal Calculation

The UMC can detect an earth fault by summing up the three phase currents without using an external current transformer. The internal earth fault detection function signals a warning when the earth fault current exceeds a set threshold for a configurable period of time, after the motor start-up. The earth fault detection function creates a trip when the current continuously exceeds a separately set threshold for a set period of time, after the motor start-up.



- Ground fault current must be $> 20\%$ of I_g to be detected
- Only usable in networks with low impedance to ground.
Only higher ground fault currents can be detected
- The set trip and warn levels should not be above 80% of I_g
- In case of fast starting motors without load an earth fault trip can happen during the start-up phase. Configure a delay time in this case.

Block Diagram:

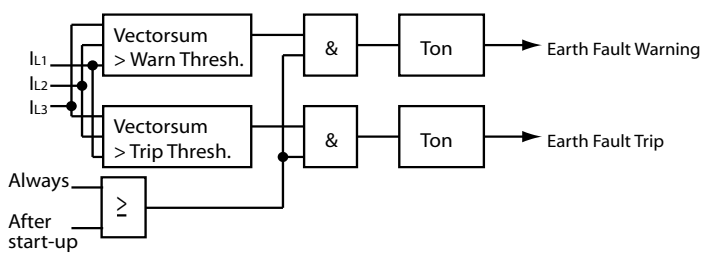

Signal flow of the internal earth fault protection function

Relevant Parameters Internal Ground Fault:

- Earth Flt Trip Level
- Earth Flt Warn Level
- Earth Flt Trip Delay
- Earth Flt Warn Delay
- Earth Flt Detection

If Trip Level and Warn Level = 255% then Earth Flt Level is not calculated.

If Trip Level or Warn Level is not 255% then Earth Flt Level is calculated and visible on panel or application.

Thermistor (PTC) Motor Protection acc. to EN 60947-8 (type A sensors)

PTC thermistors are semiconductor elements with a very high positive temperature coefficient. They are embedded directly in the phase windings of the stator. In contrast to the thermal overload protection that responds to the load current, the thermistor protection responds to the change in thermistor resistance due to temperature change in the motor windings. The thermistors are selected to have a rated operating temperature that corresponds to the insulation class, type and construction of the motor. At the rated temperature the thermistor resistance increases sharply up to the hot temperature resistance value.

The UMC senses this abrupt change in the resistance. When thermistor protection is activated there is also an internal supervision which detects open or short-circuit faults from the thermistor circuit.

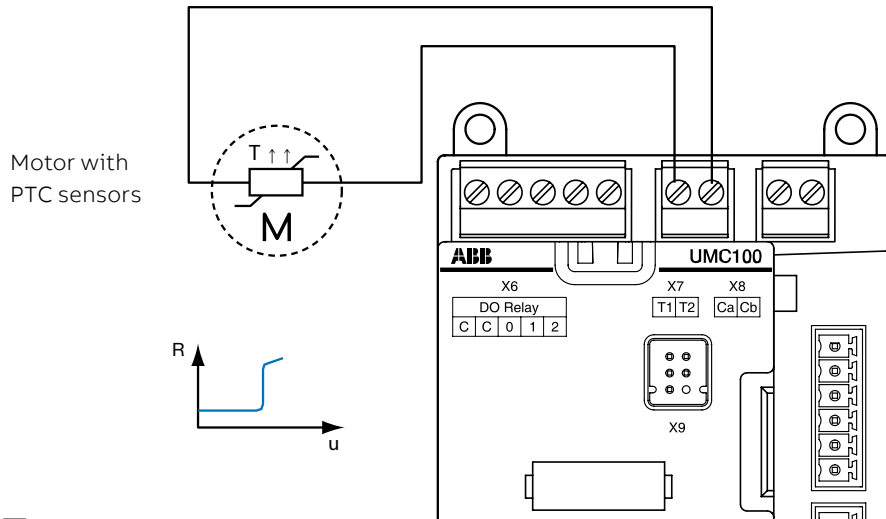

Connect the PTC to the T1/T2 terminals of the UMC

Relevant Parameters:

- PTC

Voltage and Power Protection Functions

This section describes the voltage based motor protection functions. The UMC100.3 together with the voltage module VI150/VI155 continuously measures the motor supply voltage (line to line), the motor current and the phase angle between the current and voltage. The power and energy consumption is calculated out of these values and used for various protection and monitoring functions. The different process values can be reported to the fieldbus and displayed on the LCD panel.

The following functions are described in this section:

- Overvoltage, Undervoltage
- Phase loss
- Voltage imbalance
- Total harmonic distortion
- Overload, Underload
- Power factor
- Voltage dip reaction

The following process data are available:

Process Value	Explanation	Data range
Power factor (cosphi)	The power factor is defined as the ratio of the real power flowing to the load to the apparent power and is a non dimensional number between 0 and 1 (also expressed as a percentage). It only considers the fundamental frequency.  In this manual both terms are used and refer to the fundamental frequency only!	0...1 (0 ... 100 %)
U_{L1L2} , U_{L2L3} , U_{L3L1} U_{LN}	Phase to phase (line to line) voltages (three-phase mode) Phase to neutral (single-phase mode)	0...115 % of U_e
Active power	Active power is the capacity of the motor for performing work in a particular time	0...65535 [1 W, 10 W, 100 W, 1 kW] The actual unit depends on the selected scaling factor.
Apparent power	The apparent power is the vector sum of real and reactive power.	0...65535 [1 VA, 10 VA, 100 VA, 1 kVA] The actual unit depends on the selected scaling factor.
Voltage Imbalance	An imbalance between the supply voltages in the network.	0 ... 100 %
Total harmonic distortion (THD)	Harmonic distortion of the mains.	0 ... 100 %
Energy	Consumed energy.	kWh



In chapter 2, section "Connecting the VI15x Voltage Module" you will find information on how to mount and connect the voltage module.

All process values generated from the voltage module can be used in the Custom Application Editor. Consult the editor's manual for more information.

The digital output of the voltage module DO0 can be freely used in the function block editor.

By default it is connected to the command telegram and can be controlled from a PLC.



Before using the voltage module set the following parameters:

- Nominal line to line voltage (three-phase mode)
- Nominal to neutral voltage (single-phase mode)
- Nominal power factor (cos phi)
- VI15x enabled.

If the module is enabled the UMC monitors the presence of the module and creates by default a fault in the event that the module is missing (-> parameter 'Missing Module Reaction').

Function Overview

Voltage-based Protection Functions	When active	Available Options: Warning/Trip/Off/Other	Automatic Fault Reset Possible
<p>Overvoltage: The highest value of the three phases is above a given threshold. The warning - and trip thresholds as well as the according delays can be set.</p>	<p>Motor running Motor stopped Not in test position</p>	Trip, Warning, Off	-
<p>Undervoltage: The lowest value of the three phases is below a given threshold. The warning - and trip thresholds as well as the according delays can be set.</p>	<p>Motor running Motor stopped Not in test position</p>	Trip, Warning, Off	-
<p>Voltage dip: Low voltage situation which requires an autonomous load shedding handling should take place in the UMC.</p>	<p>After motor start Not in test position</p>	Reaction depends on dip duration.	-
<p>Phase loss: In opposite to the current based phase loss protection function this function detects a missing phase also in the case the motor is stopped. A warning / trip can be signalled before the motor is actually started i.e. to detect a blown fuse.</p>	<p>Motor running Motor stopped Not in test position</p>	Trip, Warning, Off	-
<p>Voltage imbalance: This function can be used to detect smaller voltage imbalances between the phases. Warning - and trip thresholds as well as warning - and trip delays can be set.</p>	<p>Motor running Motor stopped Not in test position</p>	Trip, Warning, Off	Yes, see parameter 'Fault auto reset'
<p>Total harmonic distortion: This function measures harmonic distortions in the connected mains.</p>	<p>Motor running Motor stopped Not in test position</p>	Warning	-
<p>Overload: The active power drawn by the motor is too high. The warning - and trip thresholds as well as the according delays can be set.</p>	<p>After load start Not in test position</p>	Trip, Warning, Off	-
<p>Underload: The active power drawn by the motor is too low. The warning - and trip thresholds as well as the according delays can be set.</p>	<p>After load start Not in test position</p>	Trip, Warning, Off	-
<p>Cos phi: A measure of the phase angle between voltage and current. The warning - and trip thresholds as well as the according delays can be set.</p>	<p>After load start Not in test position</p>	Trip, Warning, Off	-

Voltage based Protection Functions

The following block diagram provides an overview of the signal flow related to voltage supervision and protection. The different voltage protection functions are usually always active (also if the motor is in stop mode). There are two exceptions a) if the UMC is in test position and b) if a voltage dip was detected.

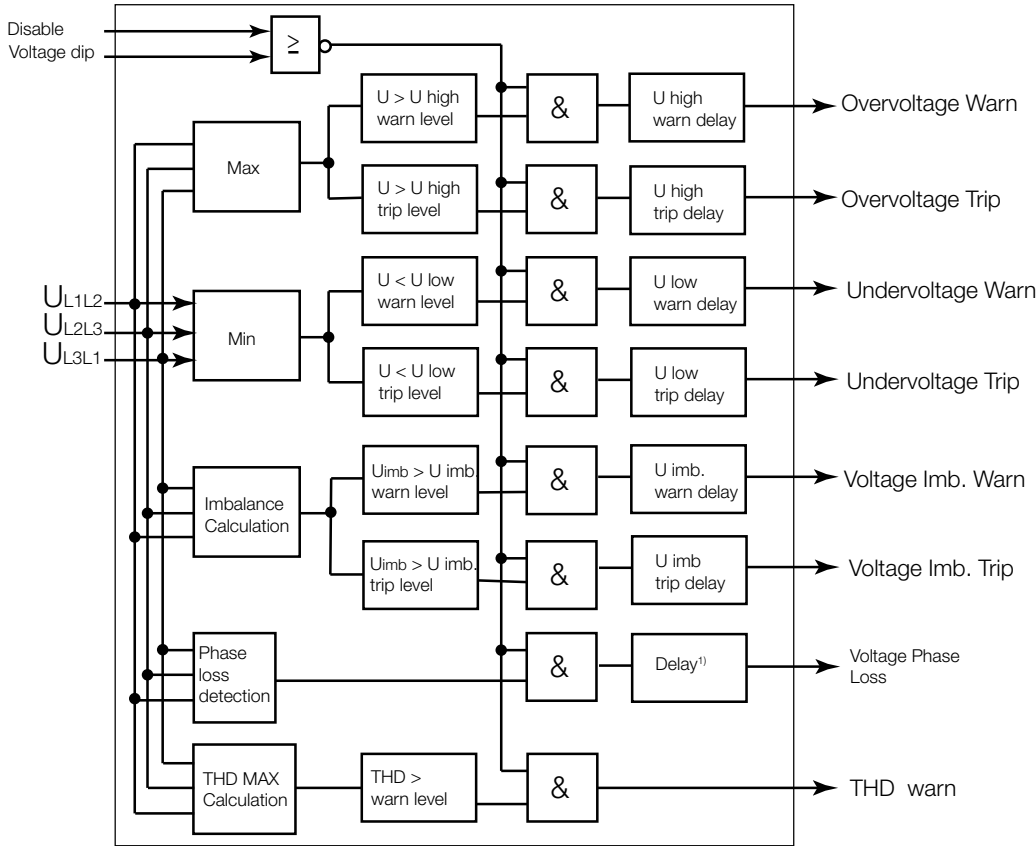

¹⁾ delay = dip duration or dip autorestart delay (the longer time is used for the delay)

Signal flow of the voltage based protection and monitoring functions

Imbalance

An imbalance can appear because of different reasons. For example because of a network imbalance or because of high contact resistances in the wiring of a phase. Even small voltage imbalances causes high current imbalances. The imbalance value is calculated as follows (max. deviation (U₁₂,U₂₃,U₃₁) is the maximum deviation phase voltage from the average voltage value):

$$value = \frac{MaxDeviation(U_{12}, U_{23}, U_{31})}{Average(U_{12}, U_{23}, U_{31})}$$

$$U_{imbalance} = \begin{cases} U_{xy}/U_e < 10\% \mapsto 0\% \\ value \ge 20 \mapsto 20\% \\ value < 20 \mapsto value \end{cases}$$

Total Harmonic Distortion

This function measures harmonic distortions in the connected mains and provides a value for Total Harmonic Distortion THD. Harmonic distortions can be caused by variable speed drives or other electronic devices. High harmonics can result in accelerated degradation of insulation and loss of service life of a motor. In case of distortions above the adjustable warnlevel, it is recommended to check the supply mains for faults or noisy equipment. The THD is defined as the ratio of the sum of the powers of all harmonic components to the power of the fundamental frequency.

A threshold can be set to trigger a warning if the THD is too high.

Power Factor and Power Supervision

The power factor and the active power are important values to detect underload or no-load situations in applications where a change of the load is not equally reflected in a change of the motor current (e.g. small pumps, conveyor belts etc.). For the supervision of the power factor a warning and a trip threshold is available. The power factor together with the motor current and the supply voltage are the basis to calculate the real power consumed by the motor. Warning and trip thresholds can be set both for overpower and underpower supervision. The power factor and power supervision functions are disabled in test position and if a voltage dip was detected. An adjustable inhibit time is available to inhibit the load supervision functions after load start. This can be used for example to allow a pump to built up pressure before the power protection becomes active. The diagram below shows the startup of a motor and the activation of the underload protection function.

It is not necessary to specify the nominal power of the motor. The UMC100.3 internally calculates it as follows:

$$P_{nom} = I_e * U_e * \cos\varphi_{nom} * \sqrt{3}$$



The warning and trip thresholds for the under - and overpower protection are therefore defined as percentage in relation to P_n . Example: $P_n = 2 \text{ kW}$. If the parameter 'P Low Trip Level' is set to 80 % the motor will be tripped, if the measured real power falls below 1.6 kW.



Use either the cos phi or the active power for low load supervision. It is not recommendet to use both at the same time.

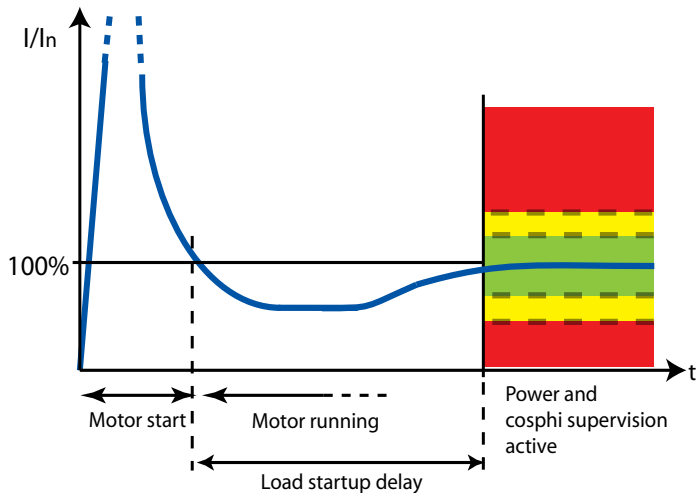

The load startup delay time allows to delay the low-power protection functions at startup. This can be used for example to allow a pump to built up pressure before the low power protection becomes active

The following block diagram shows the data flow of the power supervision in the UMC/VI15x and the generated signals.

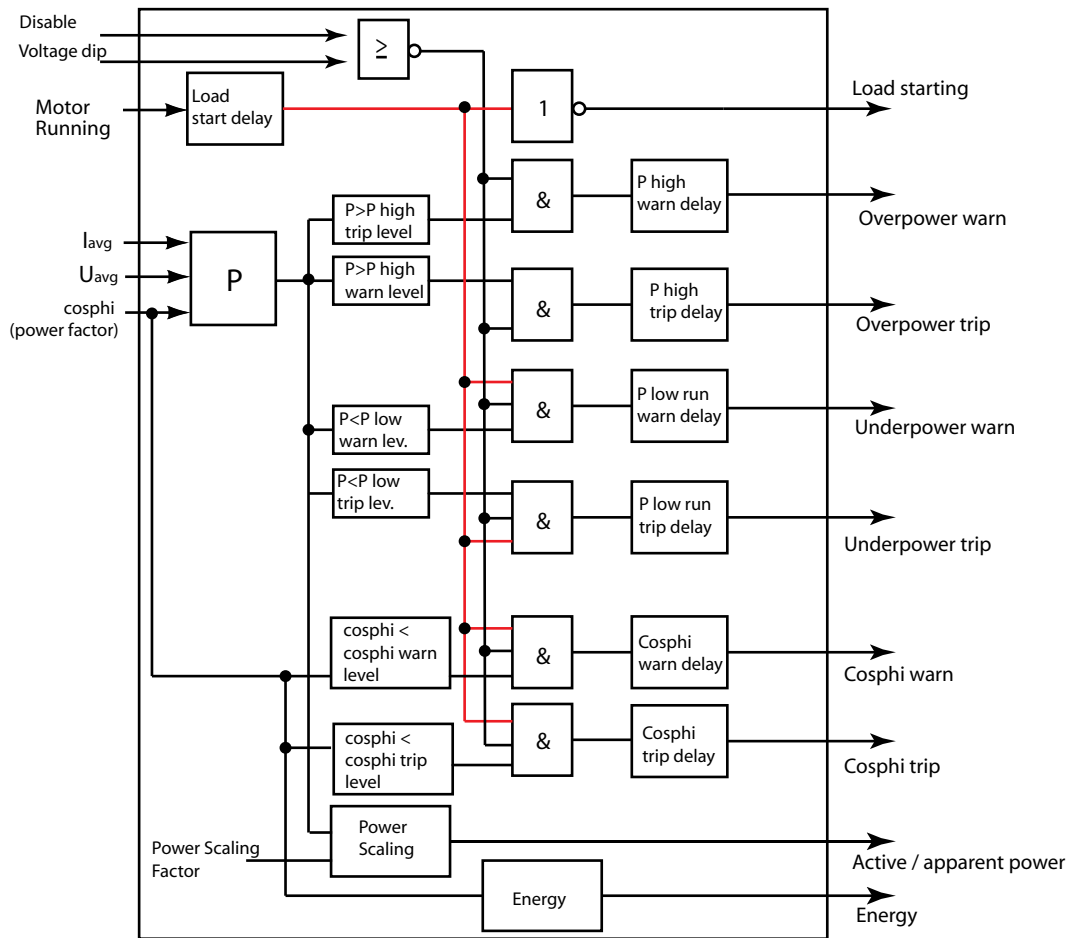

Block diagram showing the data flow of the power protection function. The signals on the right are available for further processing e.g. in a user defined custom application

Relevant Parameters Voltage	Relevant Parameters Power
• U High Warn Level	• PwrFactor Warn Level
• U High Trip Level	• PwrFactor Trip Level
• U High Warn Delay	• PwrFactor Warn Delay
• U High Trip Delay	• PwrFactor Trip Delay
• U Low Warn Level	• Load Startup Delay
• U Low Trip Level	• P Low Trip Delay
• U Low Warn Delay	• P Low Trip Level
• U Low Trip Delay	• P Low Warn Delay
• U Imb. Warn Level	• P Low Warn Level
• U Imb. Trip Level	• P High Trip Level
• U Imb. Warn Delay	• P High Trip Delay
• U Imb Trip Delay	• P High Warn Level
• THD Warning Level	• P High Warn Delay
• THD Warning Delay	• Power Scale Factor

Voltage Dips, Load Shedding

Motors switched off during voltage dips or power failure can be restarted on power resumption sequentially to prevent simultaneous switch-on of the motors and thus prevent another mains failure on the network. The tripping of motors due to undervoltage of short duration can be bypassed. It is also possible to restart the process on power resumption by sequentially starting the motors (staggered start).



The Voltage Dip function is available for the starter types DOL (Direct Online Starter) and REV (Reversing Starter).



When using the voltage dip function take care about the availability of the contactor supply voltage and the contactor fallback.

Set the check back delay time > the auto restart window to avoid trips before the UMC has switched off the contactor if the dip is longer than the auto restart window.



During a voltage dip the UMC inhibits low voltage, low cos phi and low power warnings and errors. Nevertheless set a sufficient delay time of e.g. min. 0.5 s for these functions to avoid conflicts with the Voltage Dip function.



During a voltage dip the supply voltage of the UMC itself must be available!

For special applications where the supply voltage is switched off too you can create an own function block application using the function block editor and using the function block 'Non Volatile SR'.

This block allows to save its output state over a power cycle.

The load shedding logic can be triggered

a) from the VI15x voltage module. See upper part of the diagram below.

b) from an external voltage monitor signalling the low voltage situation to several devices. See lower part of the diagram below.

No VI15x module is needed in this case.

The following diagram shows both solutions:

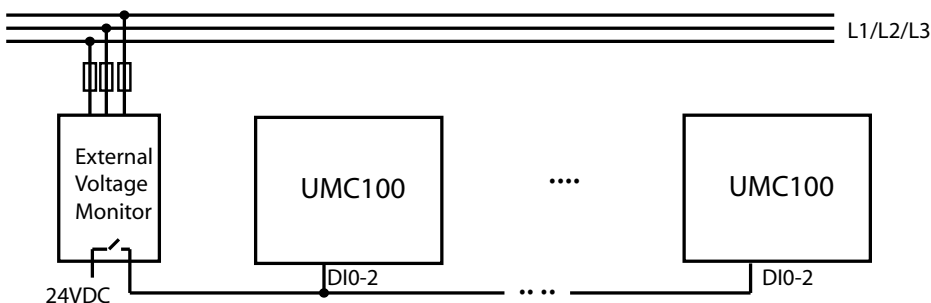
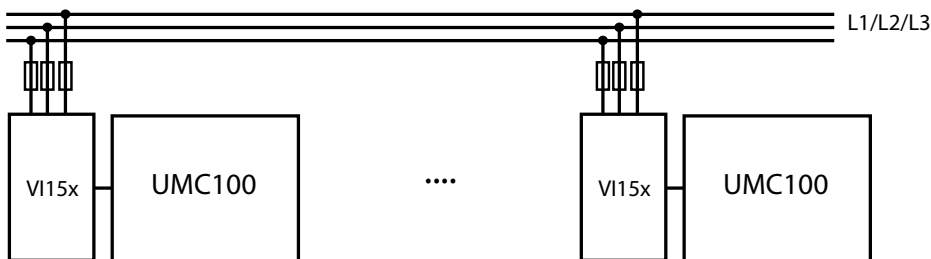

A low voltage situation can be detected either by the VI15x module or using an external voltage monitoring relay. In the latter case the low voltage signal has to be wired to all motor controllers

Parameter Description

Parameter	Explanation
Dip Duration	If the voltage dip is longer than this time a 'Dip Duration' error is triggered.
Dip Autorestart Window	If the voltage recovers within this time the motor is not switched off - i.e. the UMC output relay is switched on.
Dip Autorestart Delay	The time delay until the motor is restarted after the end of a voltage dip. This is done only if the parameter 'Dip Autorestart Enable' is set.
Dip Enable	Dip function is enabled.
Dip Autorestart Enable	Activate the automatic restart.
Dip Level	Voltage level indicating the begin of a voltage dip
Dip Restart Level	Voltage level indicating the end of a voltage dip.

Depending on the duration of a voltage dip and the parameters above different reactions can be configured. The following four diagrams show different cases.

- Case a: short low voltage situation. The motor keeps running.
- Case b: longer low voltage situation with motor stop. The motor is automatically re-started after a delay.
- Case c: long low voltage situation triggering an error
- Case d: two dips within a short period of time

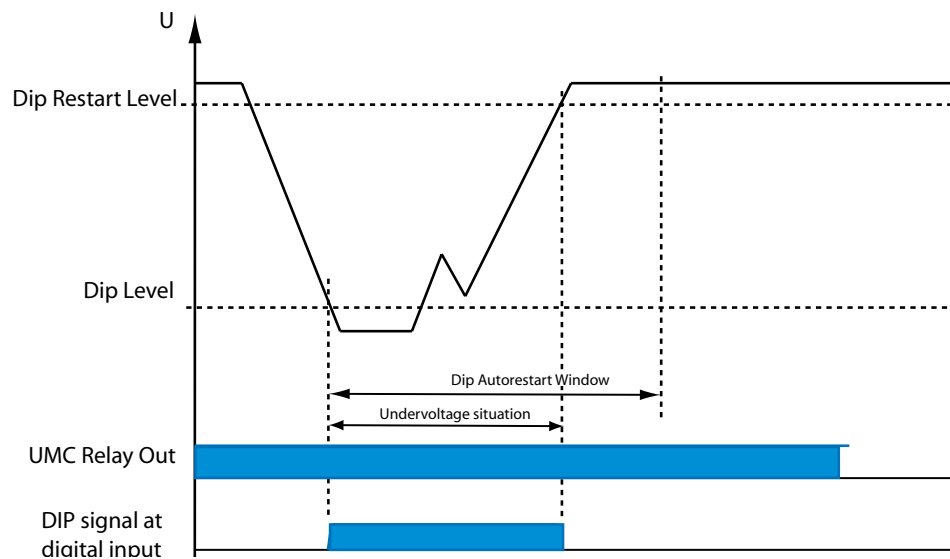

Case A:

The low voltage situation is shorter than the 'Dip Autorestart Window' so the UMC output relay does not open. The motor keeps running without interruption.

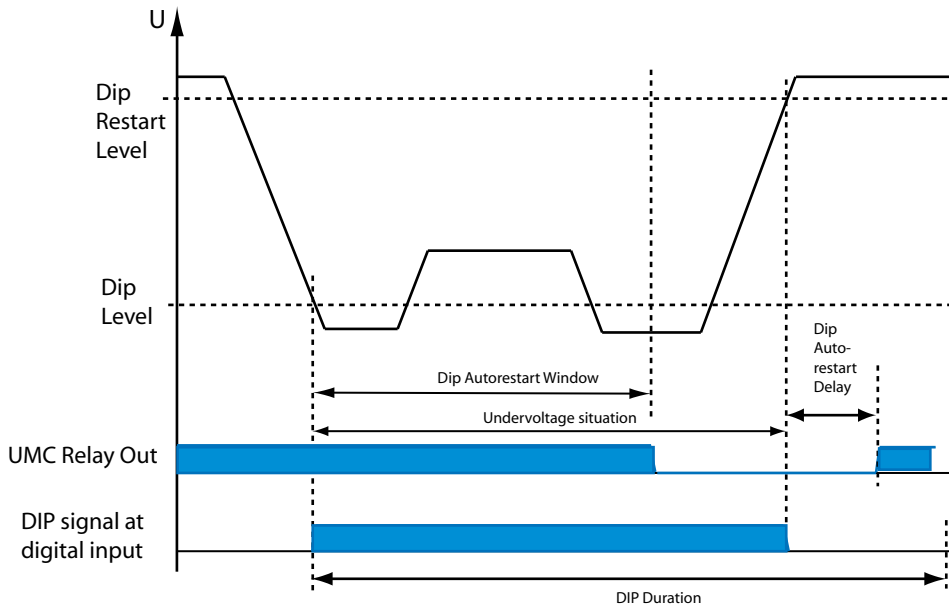

Case B:

The low voltage situation takes longer than the configured 'Dip Autorestart Window' which means the UMC switches off the relay output. But the low voltage situation is shorter than the configured 'Dip Duration' so the motor gets started automatically after an optional restart delay time (Parameter 'Dip Autorestart Enable=On). Otherwise it stays off

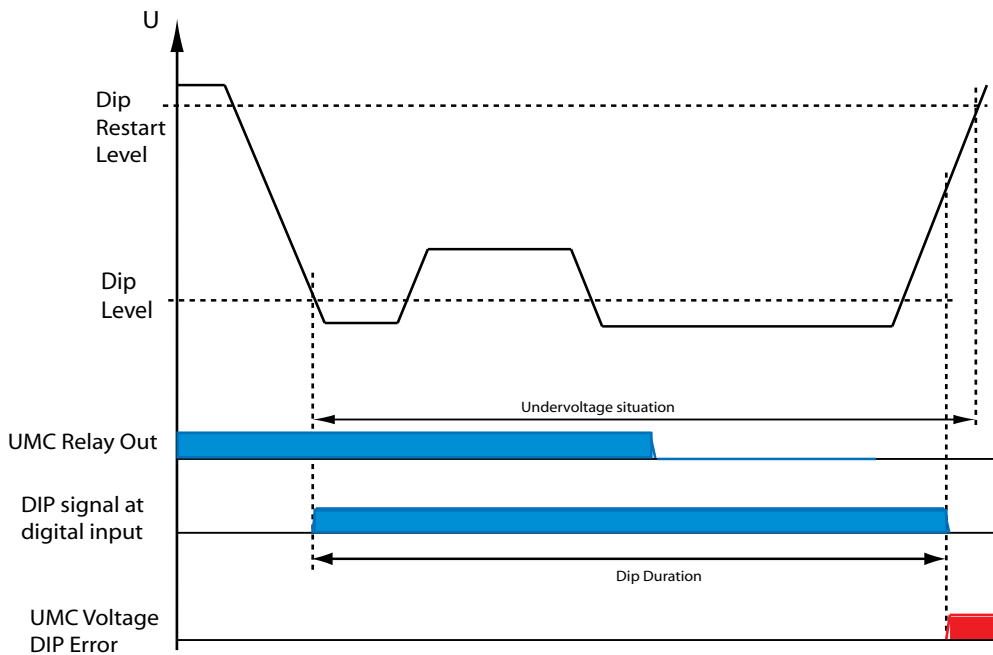

Case C:

The low voltage situation takes longer than the 'Dip Duration' time. Therefore an error is generated as soon as the dip duration exceeds the configured dip duration time

Double Dips

Special handling can be activated if two dips occur within one second. Set parameter 'Dip Enable' to 'On + Rapid Cycle Lockout'. If within one second two low voltage situations occur, immediately after the start of the second low voltage situation the contactors are switched off. They are automatically switched on again after the 'Dip Autorestart Delay' time if 'Dip Autorestart Enable' is set.

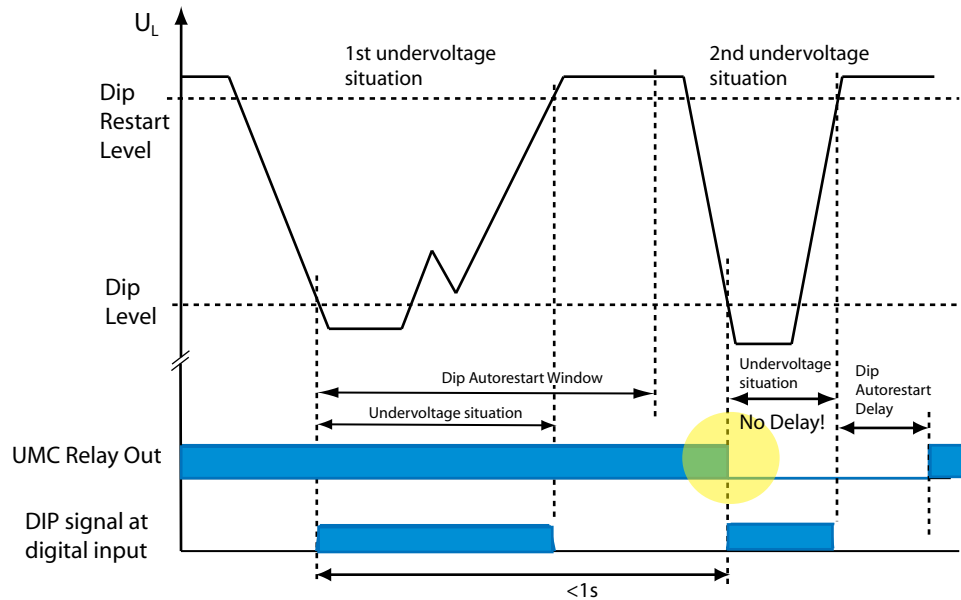

Relevant Parameters:

- Dip Enable
- Dip Duration
- Dip Autorestart Window
- Dip Autorestart Delay
- Dip Autorestart Enable
- Dip Level (only when using the VI15x modules as trigger source)
- Dip Restart Level (only when using the VI15x modules as trigger source)

RTD based Temperature Supervision and Analog Inputs

This section describes the supervision functions available together with the analog input module. The process values and generated diagnosis and trip information are available via fieldbus and LCD panel. The AI111 can operate in two modes. Use the temperature mode for supervision of three temperature values connected to the same type of sensor. Use the universal mode for full flexibility with different sensors connected to the analog inputs. Two AI111 can be connected to a UMC100. Both modules can be configured independently from each other.

The following functions are described in this section:

- Using the analog input module in temperature mode
- Using the analog input module in universal mode

The following process data are available:

Process Value	Explanation	Data range
AI value	Measured value of the channels one to three of the two analog input modules (six values).	Kelvin (temperature mode) Raw value (universal mode)
T_{max}	Max value of the three channels of an analog input module in temperature mode	Kelvin (temperature mode)



In chapter 2, section "Connecting the Analog Input Module" you will find information on how to mount and connect the analog input module.

All process values generated from the analog module can be used in the Custom Application Editor. Consult the editor's manual for more information.



Before using the analog module set the following parameters:

- AM1, AM2 Mode
- Channel Type (only for channel one in Temperature Mode)
- AM1/2 enabled. If the module is enabled the UMC monitors the presence of the module and creates by default a fault in the event that the module is missing (-> parameter 'Missing Module Reaction').

Temperature Mode

In temperature mode the analog input module measures three temperatures in two or three wire mode. The same sensor type and temperature range is used for all three inputs. The max. temperature of the three inputs is calculated and compared to the user defined warn - and trip level. In case the max. temperature rises above the configured levels a warn or trip is triggered. In temperature mode the parameters of channel one define the behaviour of all the three channels of a module. Typical usage: winding or bearing temperature supervision.

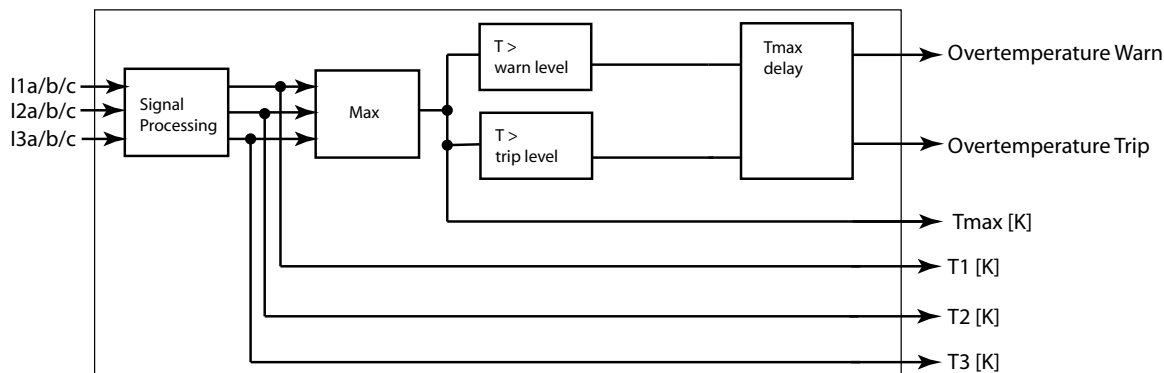

General function description of AI111 in temperature mode.

Settings for channel 1 (type and levels) are also used for channel two and three

Relevant Parameters in Temperature Mode:.

- AI1xx AM1/2 enabled
- AM1/2 mode
- AM1/2 CH1 type
- AM1/2 CH1 err reac
- AM1/2 Tmax trip level
- AM1/2 Tmax warn level
- AM1/2 Tmax delay
- LCD Panel Temperature Unit

Universal Mode

In universal mode the type of each analog input channel can be configured individually. The measured values are available on the LCD, fieldbus and function block editor. No predefined processing is done with the measured values. Processing can be done either in the control system or in a custom application created by the custom application editor.

See custom application editor handbook for a detailed description of the available function blocks and a sample application.

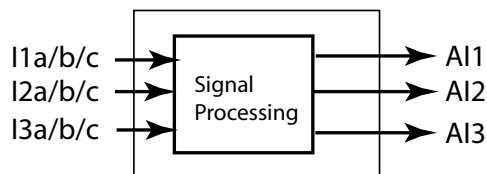

General function description of AI111 in universal mode

Relevant Parameters in Universal Mode:

- AI111 AM1/2 Enabled
- AM1,2 Mode
- AM1,2 CH1/2/3 Error Reaction
- AM1,2 Channel 1/2/3 Type

Parameterizing, values and measuring ranges

Temperatures

- Trip and warn levels are configured in Kelvin (to avoid the use of negative values); 0 °C = 273 K
- Temperature values shown in software tools and transferred via communication interfaces are in K
- On the control panel it can be selected if temperatures are shown in Celsius or Fahrenheit

Analog values 0/4...20 mA, 0...10V

- Trip and warn levels are configured with a value range of 0 to 27648 dec (6C00 hex)
- Analog values shown in software tools and transferred via communication interfaces are within a value range of 0 to 27648 dec (6C00 hex)
- On the control panel the values are shown directly in mA or V

5 Configuring the Motor Management Functions

In this section you find the following information:

- Introduction into the supported control stations and operation modes
- How to start and stop the motor from the different control stations
- Available control functions
- Functions related to motor control such as emergency start, checkback monitoring etc.

Starting and Stopping the Motor

Control Stations

From control stations (i.e. source of commands) start/stop commands can be sent to the UMC. Four control stations are supported:

- **Digital Inputs:** Allow the motor to be controlled from a control panel with push buttons e.g. mounted locally to the motor.
- **DCS/PLC:** Commands are transferred via cyclic communication telegrams from the process controller via fieldbus to the UMC. The UMC uses the PNO motor starter profile which defines the meaning of each bit in the cyclic telegrams. **LCD-Panel:** Allows control via the buttons of the UMC-PAN usually mounted in the switchgear cabinet door. **Service Tool:** Allows control commands to be issued via acyclic communication services of the used fieldbus. The UMC FIM uses this communication channel for example.
- **FIM UMC Edition software:** The "operate" mode allows control commands like start, stop, fault reset. These commands are using the acyclic communication services.

For each control station you can configure if a start and/or a stop command is accepted by the UMC.

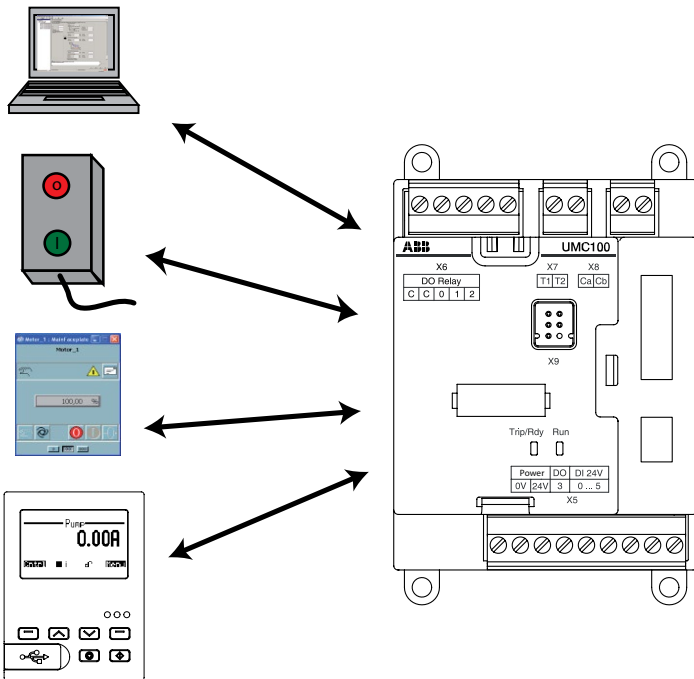

Modes

In practice it is often required to release or block start/stop commands from a control station depending on various reasons e.g.

- If the communication to the bus master is interrupted you want to automatically enable control via digital inputs which would not be possible if the communication is ok
- For service purposes all commands from the bus should be ignored

Therefore the UMC enables start/stop commands to be individually released or blocked from a control station depending on modes. Three different modes are available named by their typical usage:

Mode	Default Behaviour
Auto (Remote)	In this operation mode the UMC accepts start commands from the DCS/PLC. To activate this control mode the "Auto Mode Bit" in the cyclic communication telegram must be set to logic one. No start commands from other control sources are accepted in this mode.
Local 1	In this mode the motor is controlled locally at the motor or the motor control room. Start commands are accepted from the digital inputs or the LCD control panel. This mode is active in the following cases: If the "Auto Mode Bit" in the cyclic bus telegram is not set i.e. the PLC/DCS has enabled local control. If the LCD panel is used to control the motor locally. As soon as the menu point "Motor Control" is entered and the UMC signals local control If the UMC detects a bus fault
Local 2	Is a second local control mode that can be activated via one of the multifunction inputs even if another mode is active. This allows local control to be enforced via digital inputs without involvement of the PLC/DCS (i.e. the "Auto Mode Bit" is ignored).

How to set the mode:

There are three relevant signals that determine which mode is active:

- Bus fault: The UMC has detected a bus fault (i.e. the cyclic bus master is missing)
- Force Local 2: A multifunction input signals that the local 2 mode shall be activated
- Autobit: With bit 5 in byte 0 of the cyclic command telegram, the PLC/DCS signals that the auto mode shall be activated and control shall happen via bus (according to PNO motor management profile).

The following table shows the activated operation mode depending on these inputs.

There is always one mode selected even if more than one input is active.

The bus fault signal has the highest priority followed by the force local 2 signal. The autobit has lowest priority.

Bus fault (e.g. no sign of life from master)	1	0	0	0
Force local 2 signal (from DI0-2)	x	0	1	0
Autobit is set to true on fieldbus	x	0	x	1
Resulting Mode	Local 1	Local 1	Local 2	Auto

x: Either 0 or 1

Mode selection table. Based on the three inputs the active mode is selected

Example:

The following requirements shall be fulfilled:

- Switch S1 has the following positions: Remote/Local/Test Position/Off.
- (Req. 1) If the switch is in position Local the UMC can only be controlled locally (digital inputs and LCD) but not started via bus. But it shall be possible to stop the motor also via bus.
- (Req. 2) In position Auto the DCS can control the UMC. Locally only a stop command can be issued.
- (Req. 3) In position Off the motor cannot be started at all
- (Req. 4) Position Test is for commissioning purposes and switches the UMC in simulation mode.
- (Req. 5) If there is a bus fault the UMC shall automatically go into local mode and allows starting/stopping via the LCD panel and the digital inputs (as in position Local).

The diagram below shows the simplified circuit diagram:

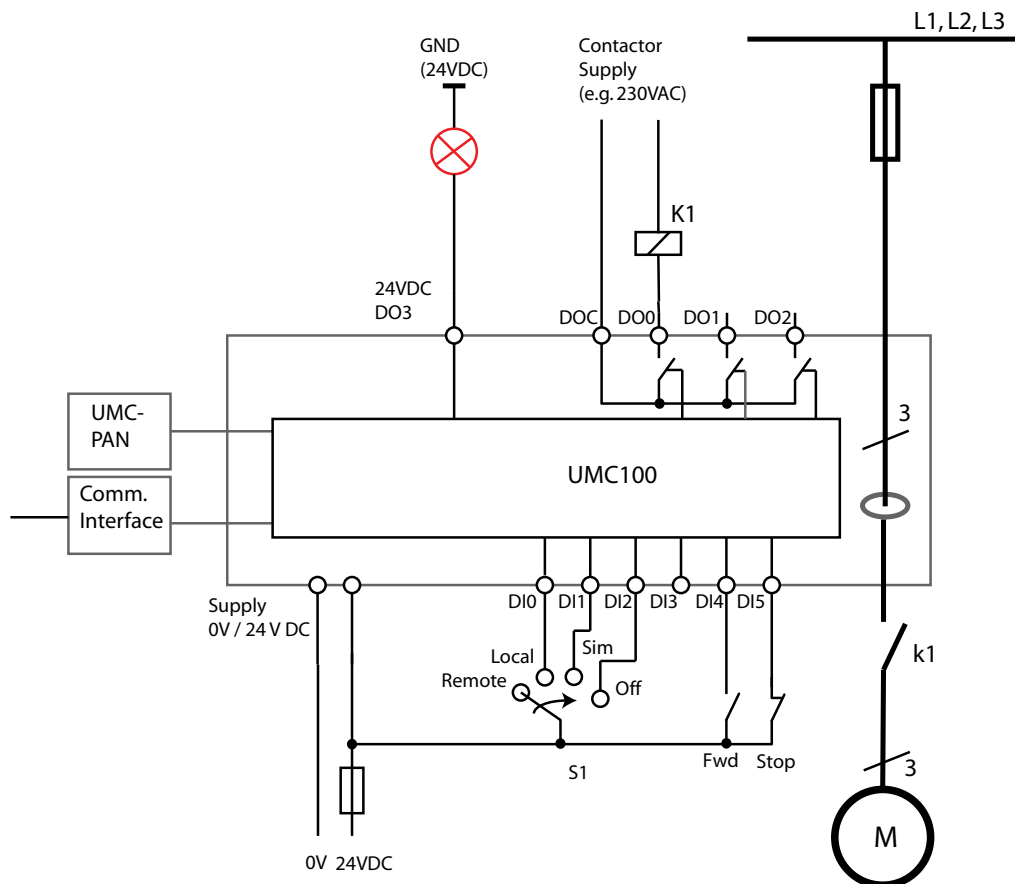

From the requirements you can see that the three control places Digital Inputs, Fieldbus and LCD are used.

Furthermore start/stop commands from the different control places shall be blocked or released depending on the Fieldbus and S1 status. Therefore the different modes can be used.

To read in the S1 commands the three multifunction inputs DI0, DI1 and DI2 are used.

Their configuration is as follows:

- Multifunction In 0 = Force Local (NO): This input activates local 2 mode if the user wants to ensure that the DCS cannot control the motor (Req 1)
- Multifunction In 1 = Test Position (NO): This input activates simulation (Req. 4)
- Multifunction In 2 = Stop: Stop (NO) is dominant and no start is permitted if the input is active (Req. 3)

For the Remote position no input is needed, because if the UMC is not in local mode, it is automatically in Auto mode

Finally it is necessary to configure from which control places the motor can be started in the different operation modes (Auto / Local).

The following parameters are set according to the requirements (Req 1, Req2, Req 5):

Settings for local mode 1 (For busfault situation)

- Loc 1 Start Bus Cyc = YES (Req. 1)
- Loc 1 Stop Bus Cyc = NO
- Loc 1 Start DI = YES (Req 5)
- Loc 1 Stop DI = YES (Req 5)
- Loc 1 Start LCD = YES (Req 5)
- Loc 1 Stop LCD = YES (Req 5)
- Loc 1 Start Bus Acyc = NO
- Loc 1 Stop Bus Acyc = NO

Settings for Auto/Remote mode (S1 in position Remote)

- Auto Start Bus Cyc = YES (Req 2)
- Auto Stop Bus Cyc = YES (Req 2)
- Auto Start DI = NO
- Auto Stop DI = YES (Req 2)
- Auto Start LCD = NO
- Auto Stop LCD = YES
- Auto Start Bus Acyc = YES
- Auto Stop Bus Acyc = YES

Settings for local mode 2 (Switch S1 in position Local)

- Loc 2 Start Bus Cyc = NO
- Loc 2 Stop Bus Cyc = YES (Req. 1)
- Loc 2 Start DI = YES (Req. 1)
- Loc 2 Stop DI = YES (Req. 1)
- Loc 2 Start LCD = YES (Req. 1)
- Loc 2 Stop LCD = YES (Req. 1)
- Loc 2 Start Bus Acyc = NO
- Loc 2 Stop Bus Acyc = NO

The following diagram shows the simplified UMC internal data flow if S1 is in position Remote as shown in the circuit diagram before.

On the left side there are the four blocks representing the control stations. Only three of them were required in the example. In the middle the so-called command control selection block is displayed. On the right the starter function block is displayed. The configuration is as above. A cross represents a YES, an empty field a NO. The active mode is REMOTE/AUTO as defined by S1. Therefore the DCS can start the motor. Other start commands (as indicated by DI4) will be blocked.

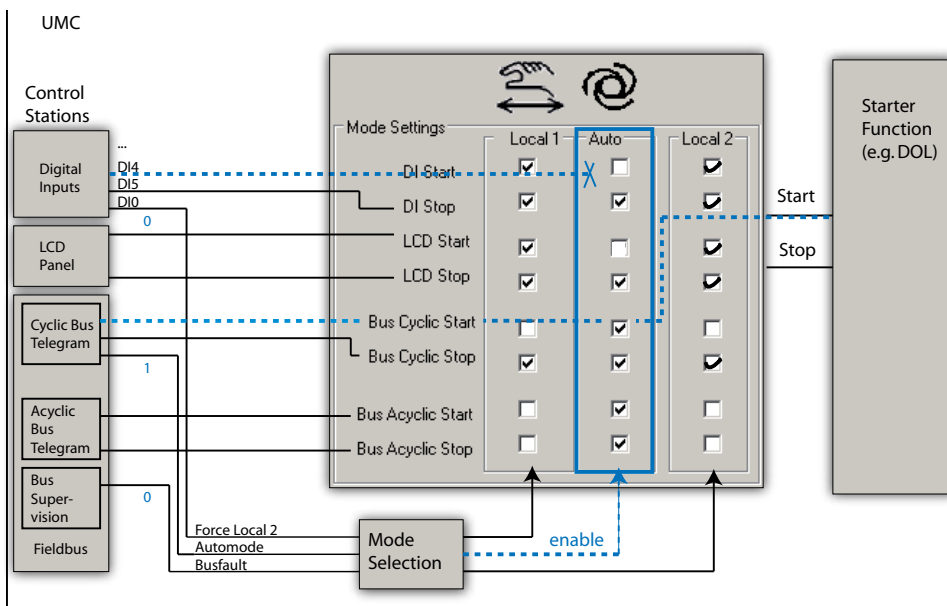

Activating Inching Mode

By default "pulses" are used to issue a start command. This means that a start input has to change its logic level to issue a start command - i.e. it is edge triggered. After the start command was accepted from the UMC the input signal can be set back to its initial value (e.g. zero). For a start signal sent from the digital inputs (DI4/DI5) it is possible to change the behaviour from pulse mode to inching mode. This means that the motor is only running while the start signal is present. If it is not present anymore the motor stops automatically.

Relevant Parameters:

- For each of the three modes Local Control 1 (Loc1), Local Control 2 (Loc2) and Auto (Auto) the following parameters are available
 - Start bus cyclic
 - Stop bus cyclic
 - Start LCD
 - Stop LCD
 - Start bus acyclic
 - Stop bus acyclic
 - Start DI
 - Stop DI
- Jog via DI (inching mode)
- Invert start DI
- Invert stop DI

Emergency Start

In some special cases a motor must be started even if the thermal overload protection would prevent the start (i.e. cooling time is still running). To allow the start in such situations the thermal memory of the UMC can be reset to cold state. This enables an immediate restart even after a thermal overload trip.

There are two possibilities for an emergency start: Using the multifunction inputs DI0, DI1 or DI2 an emergency start is carried out as follows:

1. Set parameter "Emergency Start = On" (default is Off)
2. Parameterise DI0, DI1 or DI2 as emergency start input
3. Switch the signal on the parameterised input to 1:
 - 0 -> 1 transition to reset the UMC100.3 thermal memory to "cold motor"
 - Continuous 1-signal to ignore fault signals on multi-function inputs (if parameterised as fault inputs)
 - Switch on motor

To perform an emergency start from the control system / fieldbus, the following steps must be carried out:

1. Set parameter "Emergency Start = On" (default is Off)
2. Send command PREPARE EMERGENCY START 0->1 transition via fieldbus to reset the UMC100.3 thermal memory to „cold motor“.
 - A continuous 1-signal ignores fault signals originating from the multi-function inputs (if parametrized as fault inputs)
3. Switch on motor



Caution: Starting a hot motor can cause motor damage or destruction of the motor.

Relevant Parameters:

- Emergency Start
- Multifunction 0,1,2

Limit the Number of Starts

This function allows to limit the number of starts within a defined time window. The length of the window can be set with the parameter "Num Starts Window". The numbers of permissible starts in this window can be set with parameter "Num Starts Allowed".

If there is only one start left a user defined reaction can be triggered. See parameter "Num Starts Prewarn".

If no start is left anymore but a start command is given a user defined reaction can be triggered.

See parameter "Num Starts Overrun".

An optional pause time "Num Starts Pause" can be set to define a waiting time after the motor was stopped that has to pass until a new start is possible. The running pause time is indicated with a flashing "t" symbol on the LCD panel. The remaining time until a new start is possible can be also displayed on the LCD panel and sent via fieldbus.

Parameter combinations:

Num Starts Allowed	Num Starts Window	Num Starts Pause	Resulting Behaviour
0	0	0	Function not active. (Default)
0	> 0	x	
> 0	0	x	
0	0	> 0	Number of starts not limited but pause between starts active
> 0	> 0	0 or > 0	Number of starts limited, window active (and pause active)

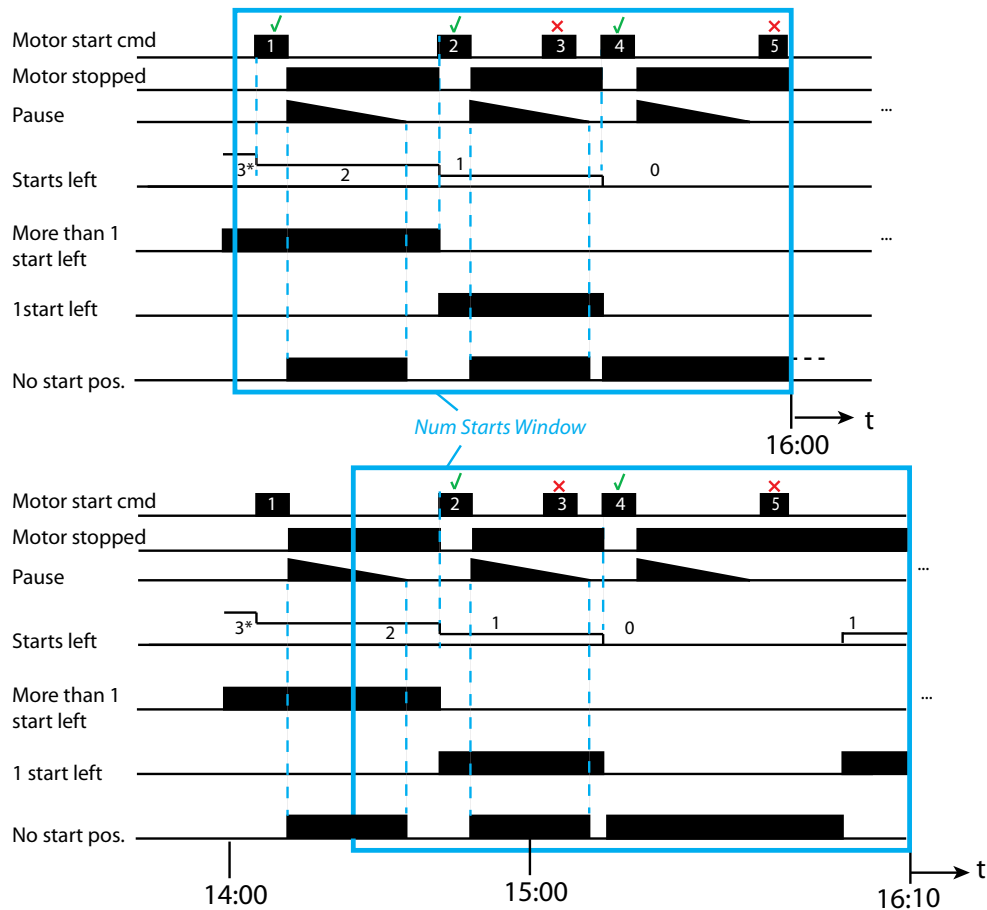

Example with 'Num Starts Allowed set to 3' shown at two points in time.

Once at 16.00 o'clock and then 10 min. later.

Top:

The 1st and 2nd start were successful. The 3rd start command was given before the pause time was over and was ignored therefore. Then the 5th start was ignored too because only 3 starts are allowed in the time window.

Bottom:

The same situation is shown 10 min. later. One start is possible again because the first start was already shifted out of the monitoring window.

Relevant Parameters:

- Num Starts Allowed
- Num Starts Overrun
- Num Starts Window
- Num Starts Prewarn
- Num Starts Pause

*) Initial counter setting depends on the parameter "Num Starts Allowed"

Checkback Monitoring

The UMC can be parameterised to monitor that the motor was really started using a checkback signal. By default the actual motor current is monitored. But it is also possible to use an auxiliary contact mounted on the main contactor.

If checkback monitoring via motor current is active it is checked that the measured current rose above 20 % within the Checkback Delay Time (t_{cbd}) after switching on the main contactor. Otherwise when the motor is switched off the function checks that the motor current is zero at the latest after the Checkback Delay Time.

For checkback via contactors one or more auxiliary contacts must be installed and wired to the UMC's digital input DI0.

The number of monitored signals depends on the selected control functions which are described in the following sections.

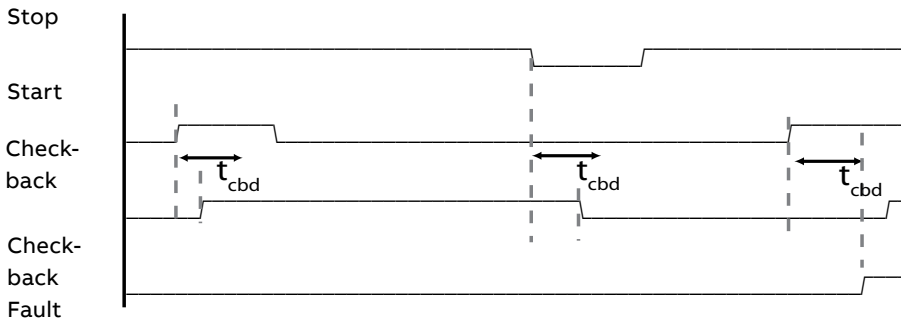

Related Parameters

- Checkback Time
- Checkback Mode

Using the Digital UMC Inputs

The UMC inputs DI0 ... DI5 are digital inputs according to IEC61131. They can be used to connect status and control signals to the UMC. UMC's reaction to these signals can be adapted in a wide range to cover typical user needs (e.g. starting the motor). The status of each digital input is available in the monitoring telegram sent to the PLC/DCS.

Using the Inputs DI3-DI5

The inputs DI3 to DI5 can be used for local motor control. DI5 is always the stop input whereas DI4 starts the motor in a forward direction and DI3 in a reverse direction (if supported by the active control function).

If inching mode is enabled the stop can still be used.

Using the Multifunction Inputs DI0-DI2

The digital inputs DI0, DI1 and DI2 are called multifunction inputs because their function can be adapted flexibly depending to your application requirements. The following diagram shows the way the multifunction inputs work.

The three multifunction inputs operate fully independent - i.e. for each input an own delay time and function can be selected. Functions like 'test position', 'stop motor' etc. internally pass an OR gate so the UMC does not differentiate from which digital input the signal came.

If an input is configured as fault input the behaviour is different. For each input its own internal error signal is available and a fault text can be specified which is displayed on the LCD panel in the event of this error.

You can thus find out what input actually triggered the fault. Faults can be auto acknowledged when the fault has been rectified.

The unchanged signal from the DI is always available for monitoring purposes (Input 1/2/3 status).

Typical usage of a multifunction input is to trigger a trip or warning because of an external signal, signal test position of a drawer or read the status of the CEM ground fault detection device.

For a full list of options see chapter "11 Parameters and Data Structures".

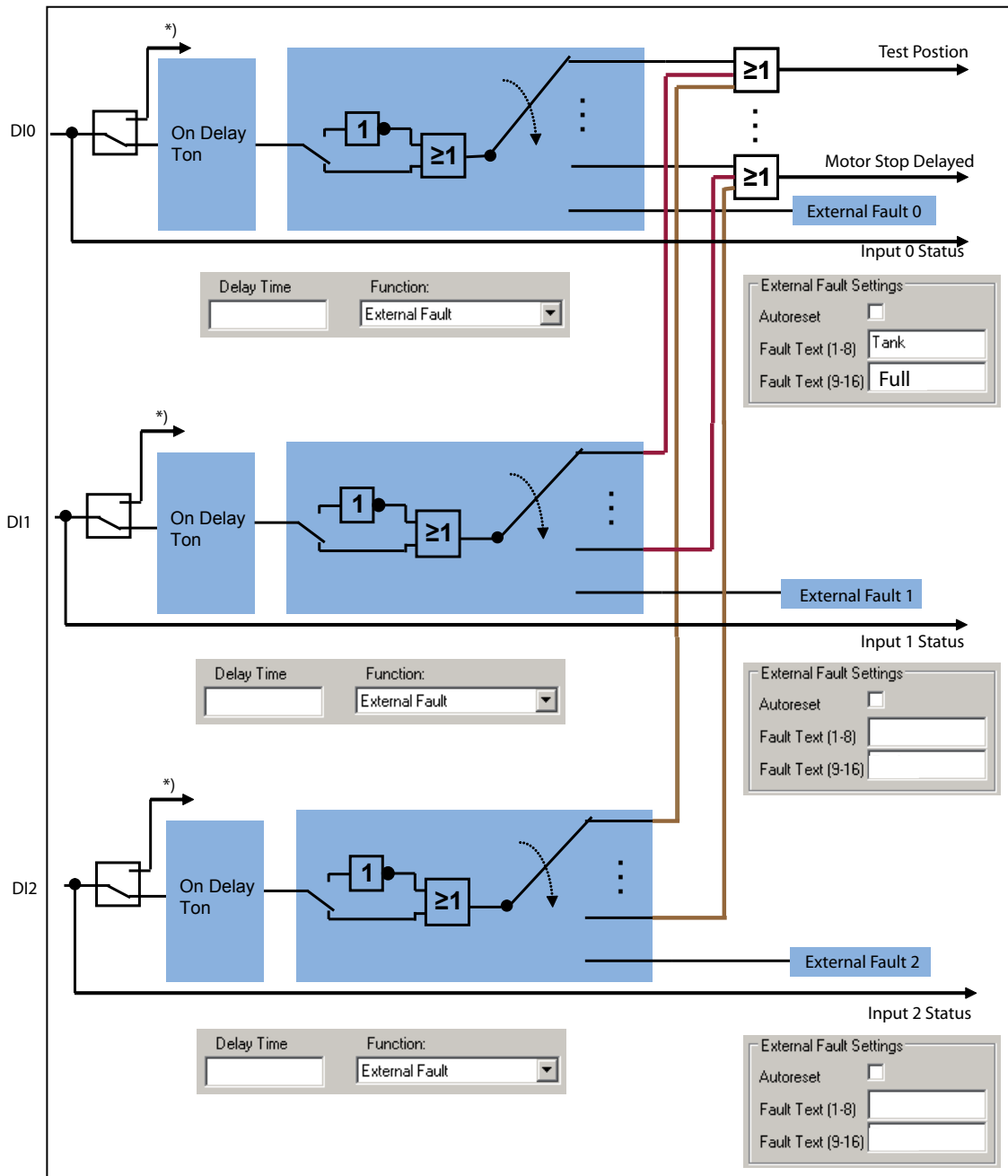

*) If a digital input is already used for the starter function (e.g. for torque inputs in the actuator modes or for contactor checkback) they are not available anymore as multifunction inputs.

Single Phase and Three Phase Operation Mode

The UMC is designed for protection and control of three phase motors (default operation mode). But it is also possible to use the UMC100.3 with single phase motors. To change the number of phases set parameter "Number Of Phases" to "1 Phase".



In single phase operation mode the following functions are not available:

- Phase sequence supervision
- Phase loss protection
- Frequency supervision
- Phase imbalance protection



Use UMC current transformer L2 for the phase conductor and L1 for the neutral conductor. Feeding the neutral conductor through the CT is optional and only required for the earth fault detection function.

Relevant Parameters:

- Number Of Phases

Stand-Still Supervision

The UMC can supervise the stand-still time of a motor. In the case the motor was not started for a user defined time the UMC can generate a warning. This warning might then be used in a customer specific way e.g. to perform a test start or do an inspection.

Relevant Parameters:

- Motor stand still level (Mot. stand still lev)

This function requires that UMC100.3 is supplied by control voltage during that time.

Run-Time Supervision

The UMC can supervise the run-time of a motor. In the case the motor exceeds the configured run-time the UMC can generate a warning. This warning might then be used in a customer specific way e.g. to trigger motor maintenance.

Relevant Parameters:

- Motor operation hours level (Mot. op. hours level)

Control Functions

The following sections describe the built-in motor control functions. For each function a simplified diagram is shown, the meaning of the command and monitoring data and a timing diagram of the relevant inputs and outputs. The control function can be set-up using the listed parameters. To fulfill specific requirements consult the manual "Custom Application Editor". The document number is listed in section "How to get started".



The following basic diagrams always show the 24 V DC supplied version of the UMC. A basic diagram with UMC100.3 UC is provided in chapter "12 Basic Circuit Diagrams".

Control Function Transparent

The UMC100.3 parametrised with the control function 'Transparent' behaves like an I/O module with an integrated overload check. The outputs DO0 ... DO3 and the inputs DI0 ... DI5 are directly connected to the fieldbus and are independent of the overload status. If a fault output (DO2 or DO3) is activated the relevant output cannot be controlled from the fieldbus anymore but is controlled by the UMC itself.

The contactor k1 can be switched on and off for example using a standard maintaining circuit (not shown).

Alternatively it can be switched on and off from the control system which uses one of the UMC relay outputs to control the motor. This option enables specific control logic to be implemented in the PLC.

The following features are not supported in this control function:

- Checkback supervision
- UMC controlled starting and stopping (bus, LCD, DI)
- Simulation and stop via multifunction inputs
- Bus fault reaction
- Voltage dip

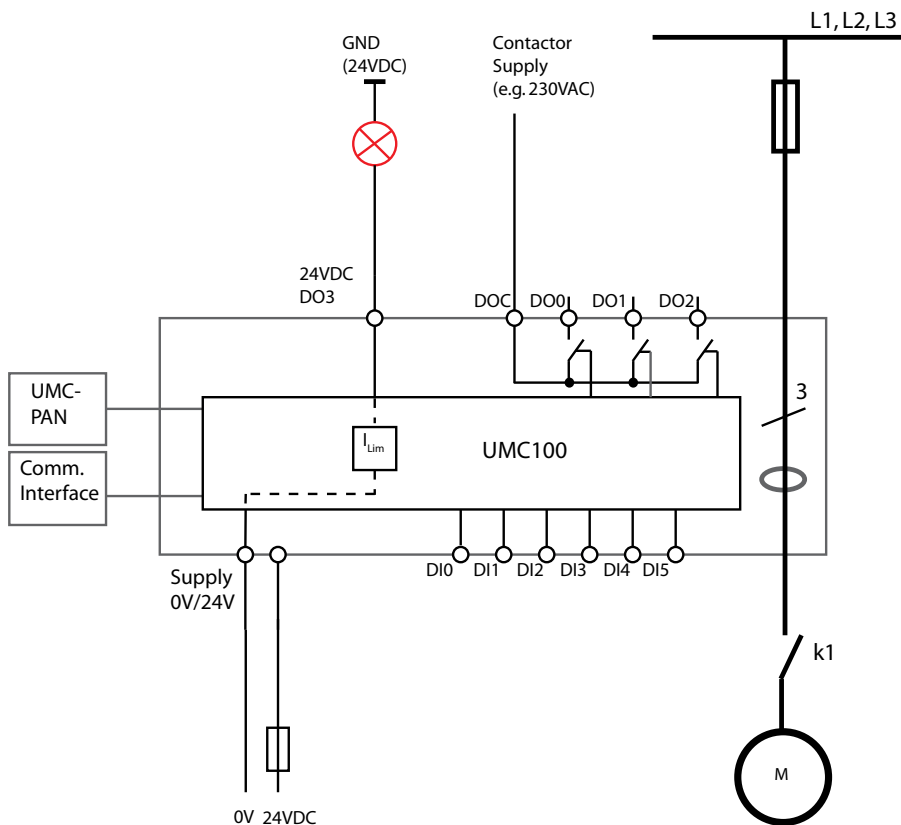

Circuit diagram of the UMC in transparent mode

Monitoring Data for Transparent

Word	Byte	Bit 7	Bit 6	Bit 5	Bit 4	Bit 3	Bit 2	Bit1	Bit 0
0	0	Summary Warning	Summary Fault	-	-	Overload warning	-	-	-
	1	UMC100 DI5	UMC100 DI4	UMC100 DI3	UMC100 DI2	UMC100 DI1	UMC100 DI0	-	-
1	2, 3	Motor Current in % of I_e (0% - 800%)							
2	4, 5								
3	6, 7								
4	8, 9								
5	10,11	Remaining data see chapter "11 Parameters and Data Structures" on a Fieldbus							
6	12								
7	13								
7	14								
	15								



The table above represents the data allocation as realised with the built-in standard applications. It may differ for customer-specific applications!

Command Data for Transparent

Word	Byte	Bit 7	Bit 6	Bit 5	Bit 4	Bit 3	Bit 2	Bit1	Bit 0
0	0	-	Fault Reset	-	Prepare Emergency Start	-	-	-	-
	1	UMC100 DO2 ¹⁾	UMC100 DO1	UMC100 DO0	UMC100 24VDC Out ¹⁾	-	-	-	-
1	2	Remaining data see chapter "11 Parameters and Data Structures on a Fieldbus"							
	3								
2	4, 5								
3	6, 7								

¹⁾ Controlled by UMC100 if configured as fault output.



The table above represents the data allocation as realised with the built-in standard applications. It may differ for customer-specific applications!

Control Function Overload Relay

The UMC100.3 parameterised with the control function 'Overload relay' can be used to replace a standard overload relay. The outputs DO2 ... DO3 and the inputs DI0 ... DI5 are directly connected to the fieldbus and not used from the control function. If a fault output is activated the fault output (DO2 or 24 V DC Out DO3) cannot be controlled from the fieldbus anymore but is controlled by the UMC itself. After powering up, contact DO0 immediately closes and contact DO1 opens. After trip due to overload, the cooling down time is applied. As long as this is the case DO1 will be energized and DO0 open.



The following features are not supported in this control function:

- Checkback supervision
- UMC controlled starting and stopping (bus, LCD, DI)
- Simulation and stop via multifunction inputs
- Bus fault reaction
- Voltage dip

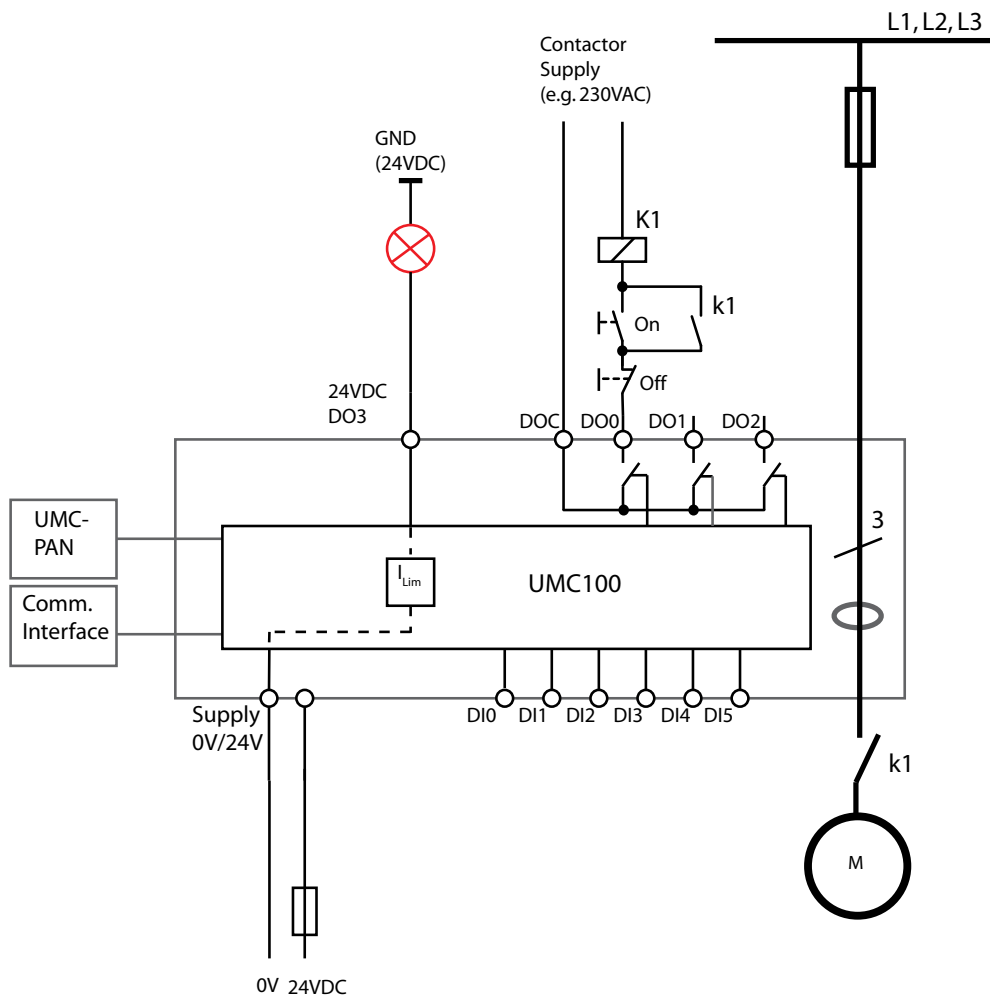

Circuit diagram of the UMC overload relay mode

Fault Behaviour:

- Contact DO0 opens
- Contact DO1 closes
- The fault output DO2/DO3 is activated if configured
- The monitoring signal FAULT is sent to the fieldbus
- The red LED on the UMC is switched on
- The FAULT signal on the control panel flashes

Monitoring Data for Overload Relay

Word	Byte	Bit 7	Bit 6	Bit 5	Bit 4	Bit 3	Bit 2	Bit1	Bit 0
0	0	Summary Warning	Summary Fault	-	-	Overload warning	-	-	-
	1	UMC100 DI5	UMC100 DI4	UMC100 DI3	UMC100 DI2	UMC100 DI1	UMC100 DI0	-	-
1	2, 3								
2	4, 5								
3	6, 7								
4	8, 9								
5	10,11	Remaining data see chapter "11 Parameters and Data Structures on a Fieldbus"							
6	12								
	13								
7	14								
	15								



The table above represents the data allocation as realised with the built-in standard applications. It may differ for customer-specific applications!

Command Data Overload Relay

Word	Byte	Bit 7	Bit 6	Bit 5	Bit 4	Bit 3	Bit 2	Bit1	Bit 0
0	0	-	Fault Reset	-	Prepare Emergency Start	-	-	-	-
	1	UMC100 DO2 ¹⁾	-	-	UMC100 24VDC Out ¹⁾	-	-	-	-
1	2								
	3								
2	4, 5	Remaining data see chapter "11 Parameters and Data Structures on a Fieldbus"							
3	6, 7								

1) Controlled by UMC100 if configured as fault output.



The table above represents the data allocation as realised with the built-in standard applications. It may differ for customer-specific applications!

Timing Diagram for Direct Starter

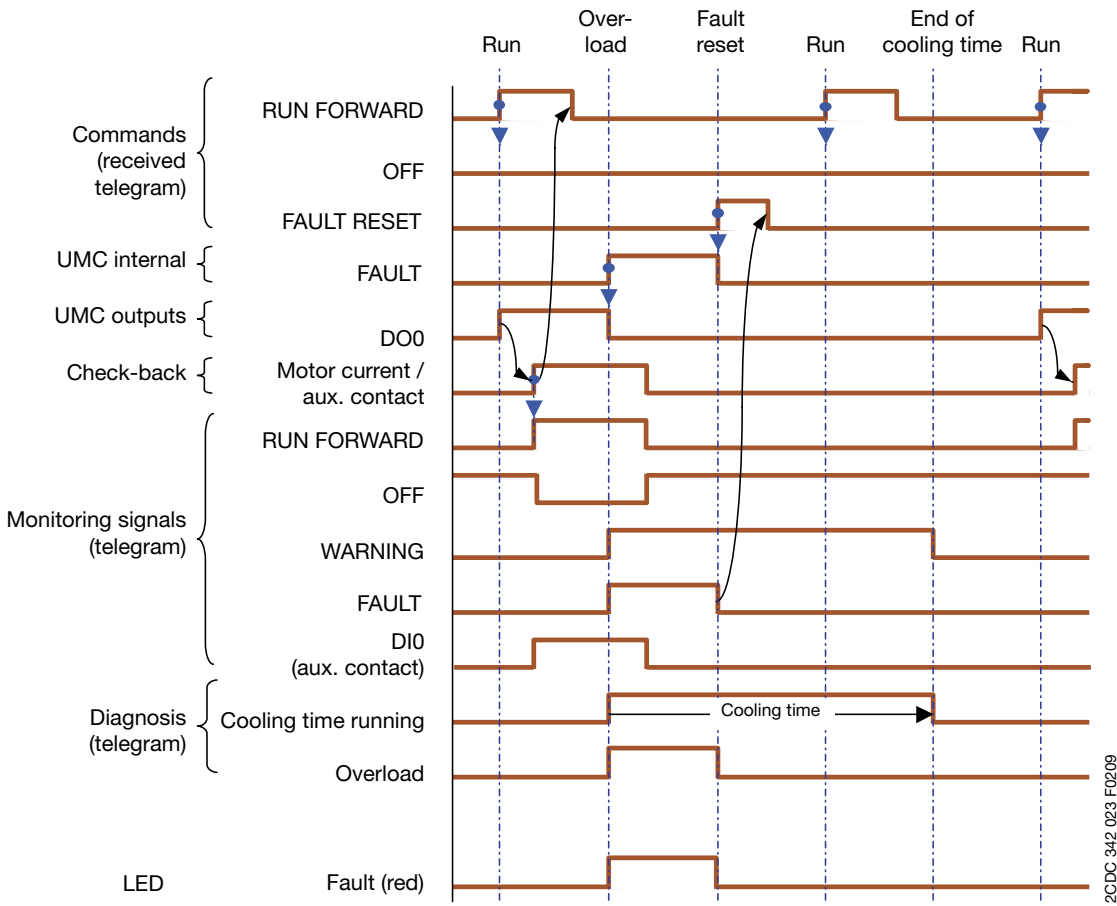

Monitoring Data for Direct Starter

Word	Byte	Bit 7	Bit 6	Bit 5	Bit 4	Bit 3	Bit 2	Bit 1	Bit 0
0	0	Summary Warning	Summary Fault	Local Control	-	Overload warning	Run Forward	Off	-
	1	UMC100 DI5	UMC100 DI4	UMC100 DI3	UMC100 DI2	UMC100 DI1	UMC100 DI0	-	-
1	2, 3								
2	4, 5								
3	6, 7								
4	8, 9								
5	10,11	Remaining data see chapter "11 Parameters and Data Structures on a Fieldbus"							
6	12								
	13								
7	14								
	15								



The table above represents the data allocation as realised with the built-in standard applications. It may differ for customer-specific applications!

Command Data for Direct Starter

Word	Byte	Bit 7	Bit 6	Bit 5	Bit 4	Bit 3	Bit 2	Bit1	Bit 0
0	0	-	Fault Reset	Auto Mode	Prepare Emergency Start	-	Run Forward	Off	-
	1	UMC100 DO2 ¹⁾	UMC100 DO1	-	UMC100 24VDC Out ¹⁾	-	-	-	-
1	2	Remaining data see chapter "11 Parameters and Data Structures on a Fieldbus"							
	3								
2	4, 5								
3	6, 7								

¹⁾ Controlled by the UMC100 if configured as fault output



The table above represents the data allocation as realised with the built-in standard applications. It may differ for customer-specific applications!

Control Function Reversing Starter (REV)

Use this function in a feeder that requires a motor to start/stop in two direction of rotation (forwards/backwards).

- Relay output DO0 is used by the control function to start the motor in a forward direction.
- Relay output DO1 is used from the control function to start the motor in a reverse direction.
- Optionally DI0 can be used for contactor checkback supervision
- Optionally DI3 / DI4 can be used to start the motor and DI5 to stop the motor
- Optionally DO2 or DO3 can be used as fault output

The following diagram shows the UMC wired for REV operation. A signal lamp is connected to DO3 which serves as a fault output. The main contactor is connected to DO0 and DO1. Two auxiliary contacts k1 and k2 are used for contactor checkback monitoring. The motor can be started locally via DI3/DI4 and stopped via DI5. The remaining digital inputs can be freely used.

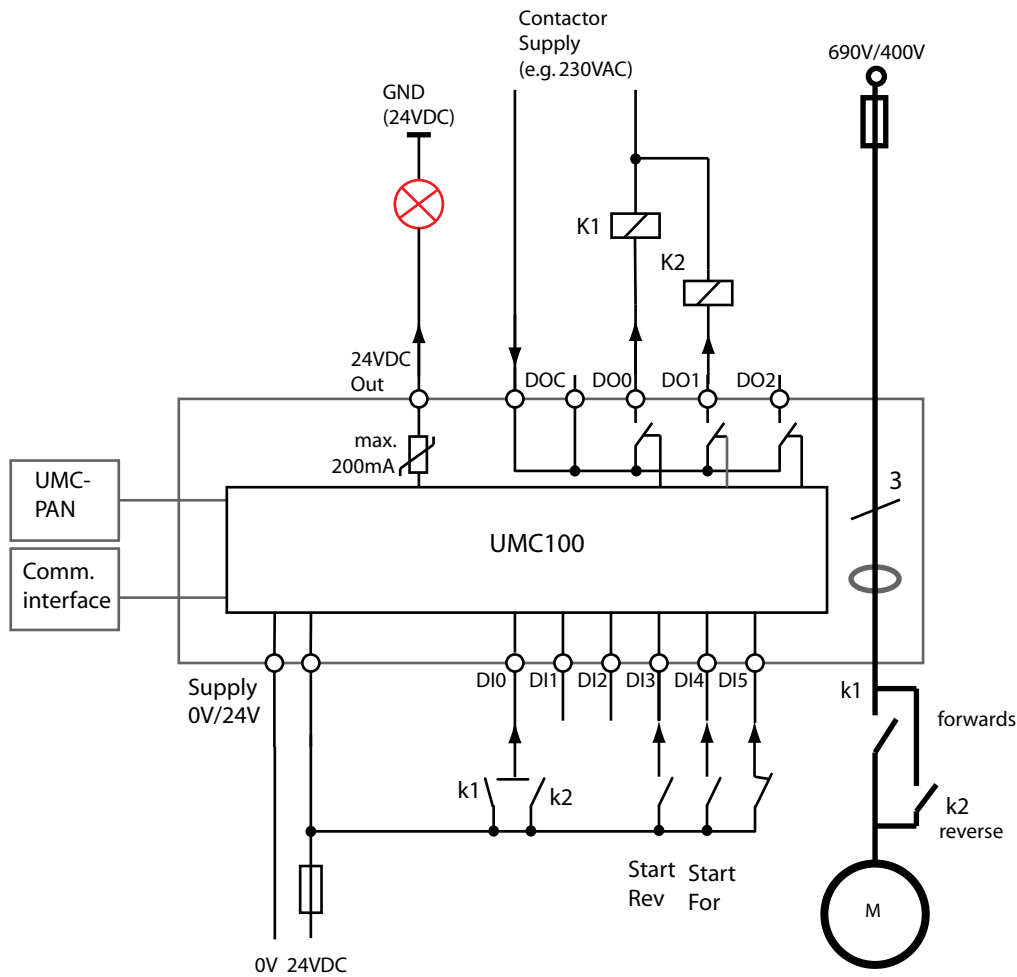

Circuit diagram of the UMC for controlling a motor in two directions of rotation. The checkback contacts k1/k2 are optional

Timing Diagram for Changing Direction

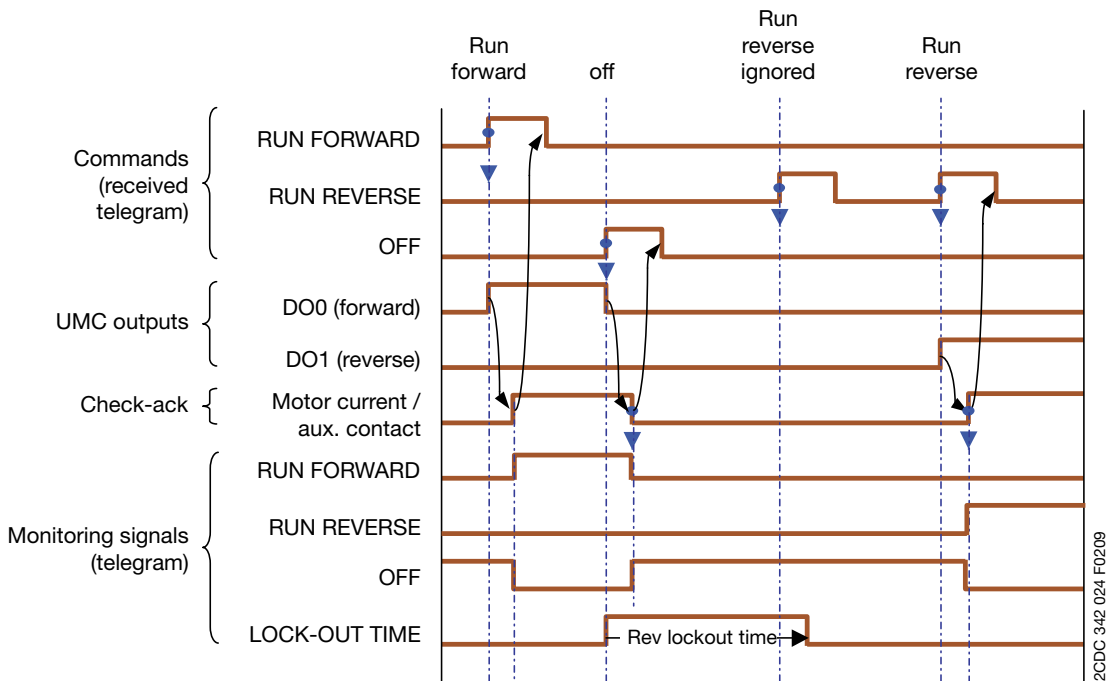

Remark:

- Opposite direction only possible after OFF and after the reverse lock-out time has elapsed.
- Restart in the same direction without consideration of the Reverse lock-out time.

Related parameters

- Reverse Lockout Time

Monitoring Data for Reversing Starter

Word	Byte	Bit 7	Bit 6	Bit 5	Bit 4	Bit 3	Bit 2	Bit1	Bit 0
0	0	Summary Warning	Summary Fault	Local Control	Reverse Lockout Time	Overload warning	Run Forward	Off	Run Reverse
	1	UMC100 DI5	UMC100 DI4	UMC100 DI3	UMC100 DI2	UMC100 DI1	UMC100 DI0	-	-
1	2, 3								
2	4, 5								
3	6, 7								
4	8, 9								
5	10,11	Remaining data see chapter "11 Parameters and Data Structures on a Fieldbus"							
6	12								
	13								
	14								
7	14								
	15								



The table above represents the data allocation as realised with the built-in standard applications. It may differ for customer-specific applications!

Command Data for Reversing Starter

Word	Byte	Bit 7	Bit 6	Bit 5	Bit 4	Bit 3	Bit 2	Bit1	Bit 0
0	0	-	Fault Reset	Auto Mode	Prepare Emergency Start	-	Run Forward	Off	Run Reverse
	1	UMC100 DO2 ¹⁾	-	-	UMC100 24VDC Out ¹⁾	-	-	-	-
1	2								
	3	Remaining data see chapter "11 Parameters and Data Structures on a Fieldbus"							
2	4, 5								
3	6, 7								

¹⁾ Controlled by the UMC100 if configured as fault output.



The table above represents the data allocation as realised with the built-in standard applications. It may differ for customer-specific applications!

Control Function Star-Delta Starter

Use this function in a feeder that requires to start/stop a motor in one direction of rotation including the time- or current-controlled transition from star to delta.

- Relay output DO0 is used by the control function to control the star contactor
- Relay output DO1 is used by the control function to control the delta contactor
- Relay output DO2 is used by the control function to control the main contactor.
- Optionally DI0 can be used for contactor checkback supervision
- Optionally DI4 can be used to start the motor and DI5 to stop it
- Optionally DO3 can be used as fault output



- The voltage dip function is not supported in this control function.
- Adjust parameter YD changeover mode
- Adjust parameter YD starting time. The switch over from Star (Y) to Delta (D) takes place earliest after 1 second. The parameter YD starting time must therefore be set to at least 1 second.

The following diagram shows the UMC wired for star-delta operation. A signal lamp is connected to DO3 which serves as a fault output. The motor contactors are connected to DO0, DO1 and DO2. Three auxiliary contacts are used for contactor checkback monitoring. The motor can be started locally via DI4 and stopped via DI5. The remaining digital inputs can be freely used.

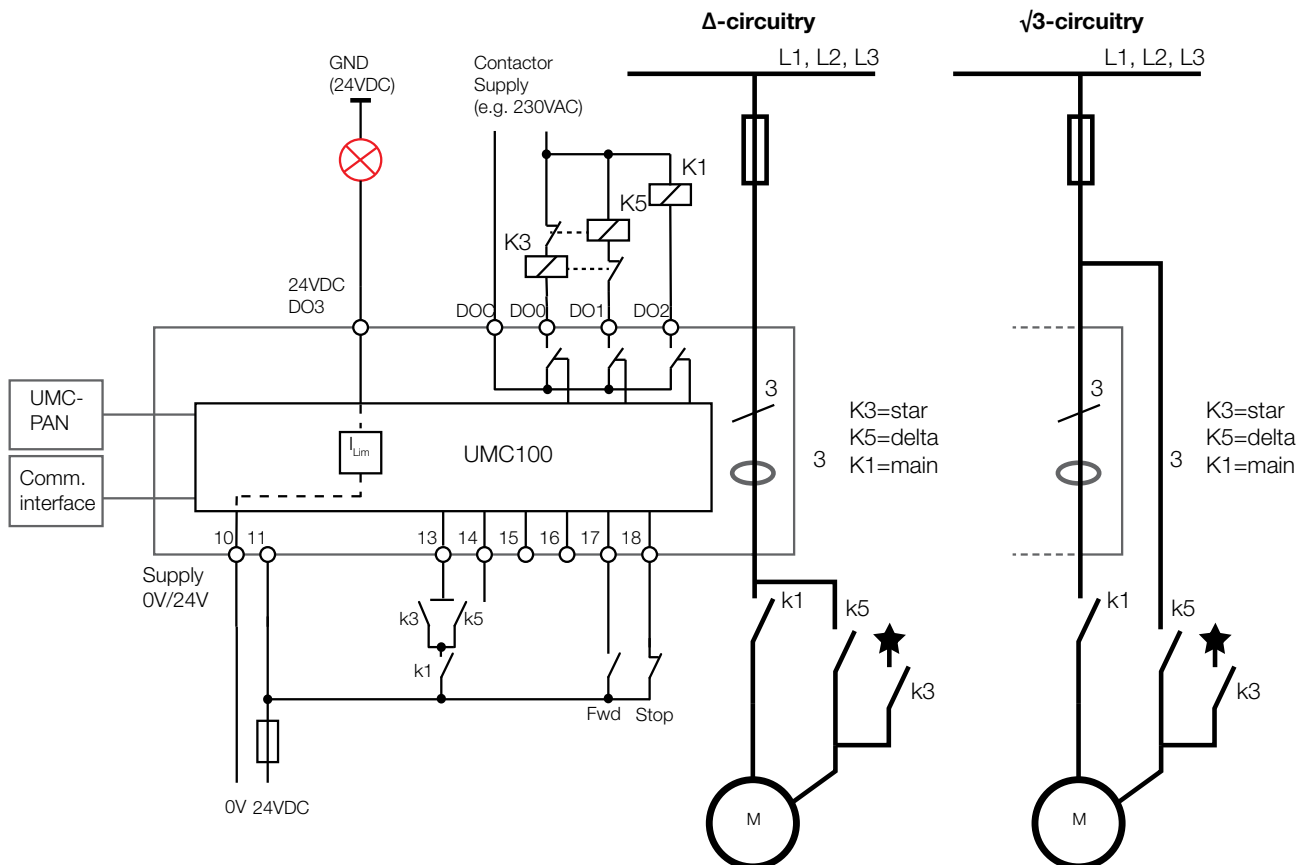

Circuit diagram of the UMC for controlling a motor in star-delta mode. The checkback contacts k3/k5 and k1 are optional

Parameters for Δ -circuitry

Current I_{e1} = nominal current

Current factor = 100 (in case of a current transformer: 100 x transmission ratio)

Parameters for $\sqrt{3}$ -circuitry

Current I_{e1} = nominal current

Current factor = 173 (in case of a current transformer: 173 x transmission ratio)

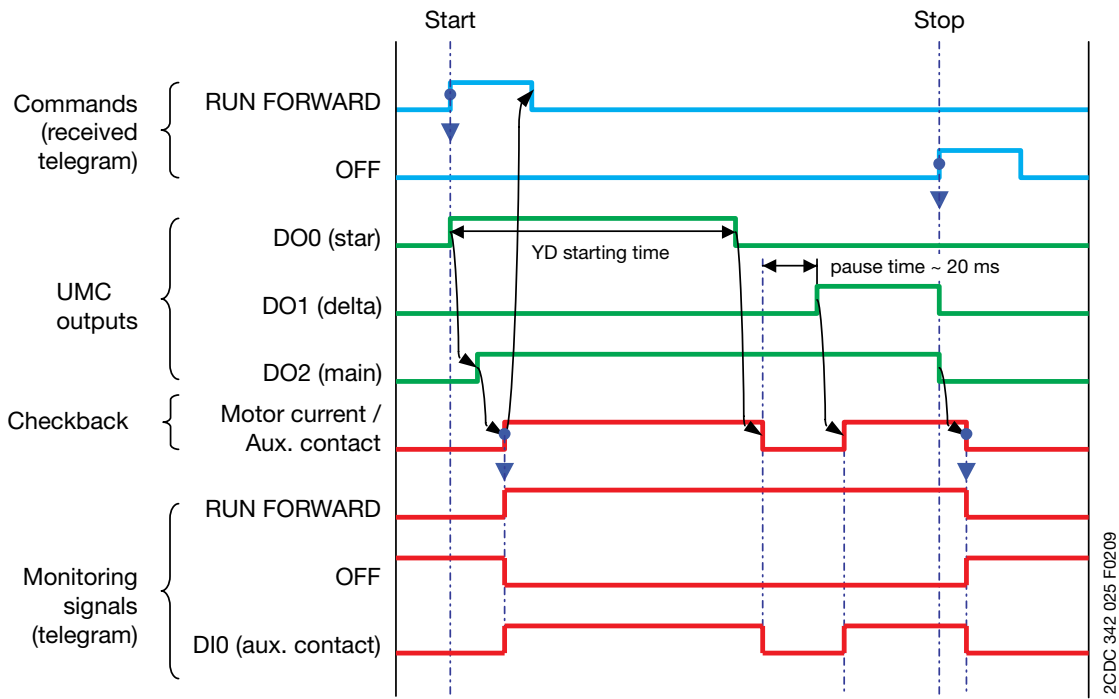

Timing Diagram for Star-Delta Starter

Monitoring Data for Star-Delta Starter

Word	Byte	Bit 7	Bit 6	Bit 5	Bit 4	Bit 3	Bit 2	Bit1	Bit 0
0	0	Summary Warning	Summary Fault	Local Control	-	Overload warning	Run Forward	Off	-
	1	UMC100 DI5	UMC100 DI4	UMC100 DI3	UMC100 DI2	UMC100 DI1	UMC100 DI0	-	-
1	2, 3	Motor Current in % of I_e (0 % - 800 %)							
2	4, 5								
3	6, 7								
4	8, 9								
5	10,11	Remaining data see chapter "11 Parameters and Data Structures on a Fieldbus"							
6	12								
	13								
7	14								
	15								



The table above represents the data allocation as realised with the built-in standard applications. It may differ for customer-specific applications!

Command Data for Star-Delta Starter

Word	Byte	Bit 7	Bit 6	Bit 5	Bit 4	Bit 3	Bit 2	Bit1	Bit 0
0	0	-	Fault Reset	Auto Mode	Prepare Emergency Start	-	Run Forward	Off	-
	1	-	-	-	UMC100 24VDC Out ¹⁾	-	-	-	-
1	2	Remaining data see chapter "11 Parameters and Data Structures on a Fieldbus"							
	3								
2	4, 5								
3	6, 7								

¹⁾ Controlled by the UMC100 if configured as fault output.



The table above represents the data allocation as realised with the built-in standard applications. It may differ for customer-specific applications!

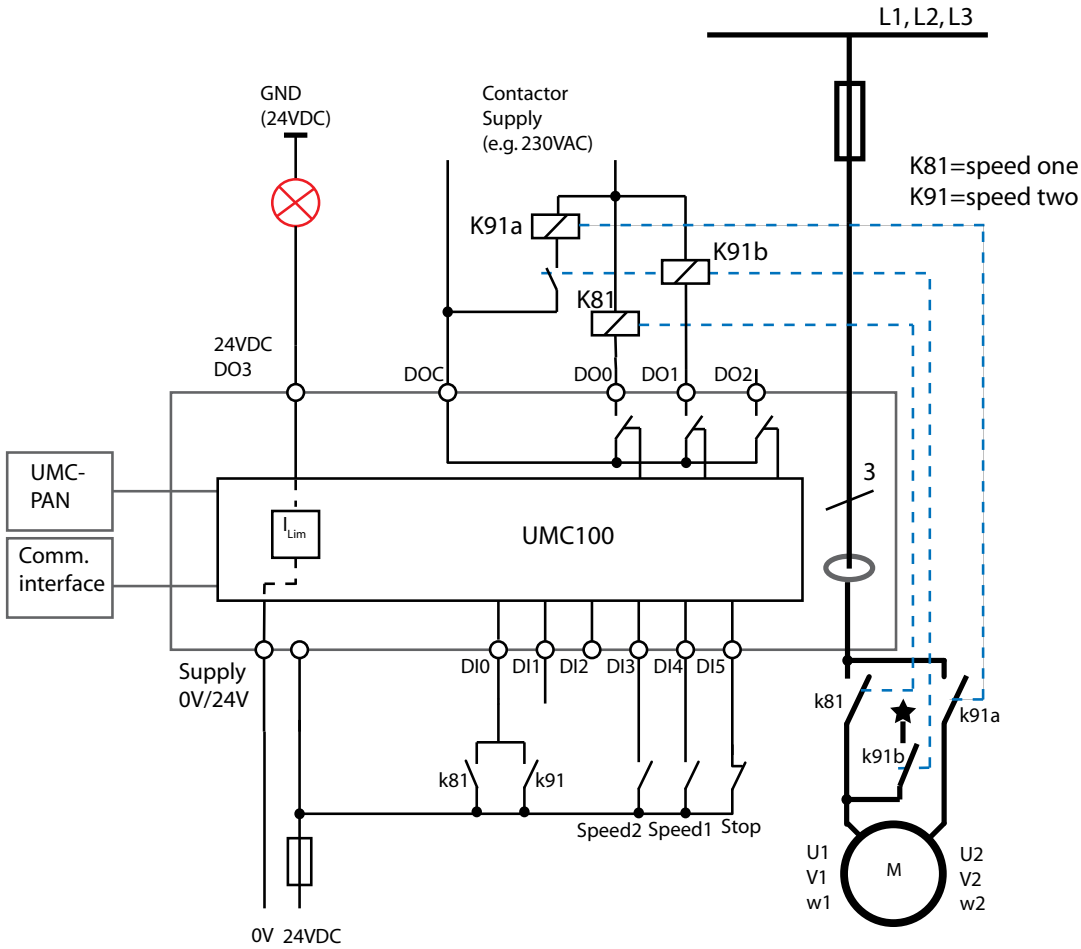

Circuit diagram of the UMC for controlling dahlander motors. The checkback contacts k81/k91 are optional

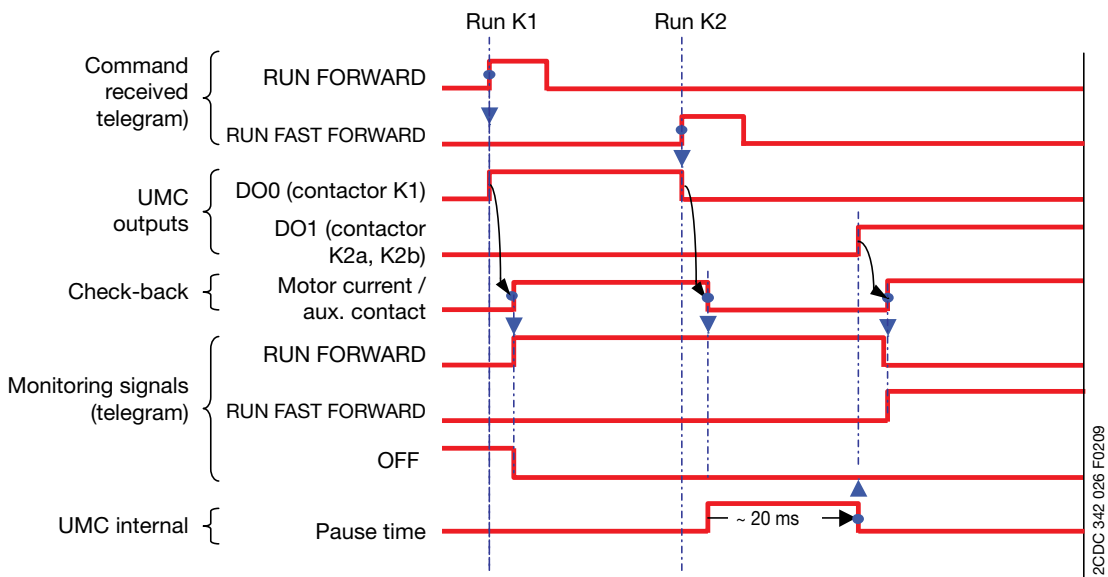

Timing Diagram for Pole-Changing Starter

2CDC 342 026 F0209

Monitoring Data for Pole-Changing Starter

Word	Byte	Bit 7	Bit 6	Bit 5	Bit 4	Bit 3	Bit 2	Bit1	Bit 0
0	0	Summary Warning	Summary Fault	Local Control	-	Overload warning	Run Forward	Off	-
	1	UMC100 DI5	UMC100 DI4	UMC100 DI3	UMC100 DI2	UMC100 DI1	UMC100 DI0	Run Fast Forward	-
1	2, 3	Motor Current in % of I_e (0 % - 800 %)							
2	4, 5								
3	6, 7								
4	8, 9								
5	10,11	Remaining data see chapter "11 Parameters and Data Structures on a Fieldbus"							
6	12								
	13								
7	14								
	15								



The table above represents the data allocation as realised with the built-in standard applications. It may differ for customer-specific applications!

Command Data for Pole-Changing Starter

Word	Byte	Bit 7	Bit 6	Bit 5	Bit 4	Bit 3	Bit 2	Bit1	Bit 0
0	0	-	Fault Reset	Auto Mode	Prepare Emergency Start	-	Run Forward	Off	-
	1	UMC100 DO2 ¹⁾	-	-	UMC100 24VDC Out ¹⁾	-	-	Run Fast Forward	-
1	2	Remaining data see chapter "11 Parameters and Data Structures on a Fieldbus"							
	3								
2	4, 5								
3	6, 7								

¹⁾ Controlled by UMC100 if configured as fault output.



The table above represents the data allocation as realised with the built-in standard applications. It may differ for customer-specific applications!

Control Function Actuator 1 - 4

Use this function in a feeder that requires the operation of an actuator that opens/closes e.g. a valve. Please note that the actuator operation mode is not able to keep a valve at a certain setpoint.

The voltage dip function is not supported and checkback via DIO is not supported in these control functions. Set the following parameters as listed here:



- Inv DI start input = No
- Inv DI stop input = No
- Inching DI start input (Jog) = Yes
- Multifunction 0/1 = Off
- Checkback: Current or Simulation (test purposes only)
- Adjust Time Limit Actuator

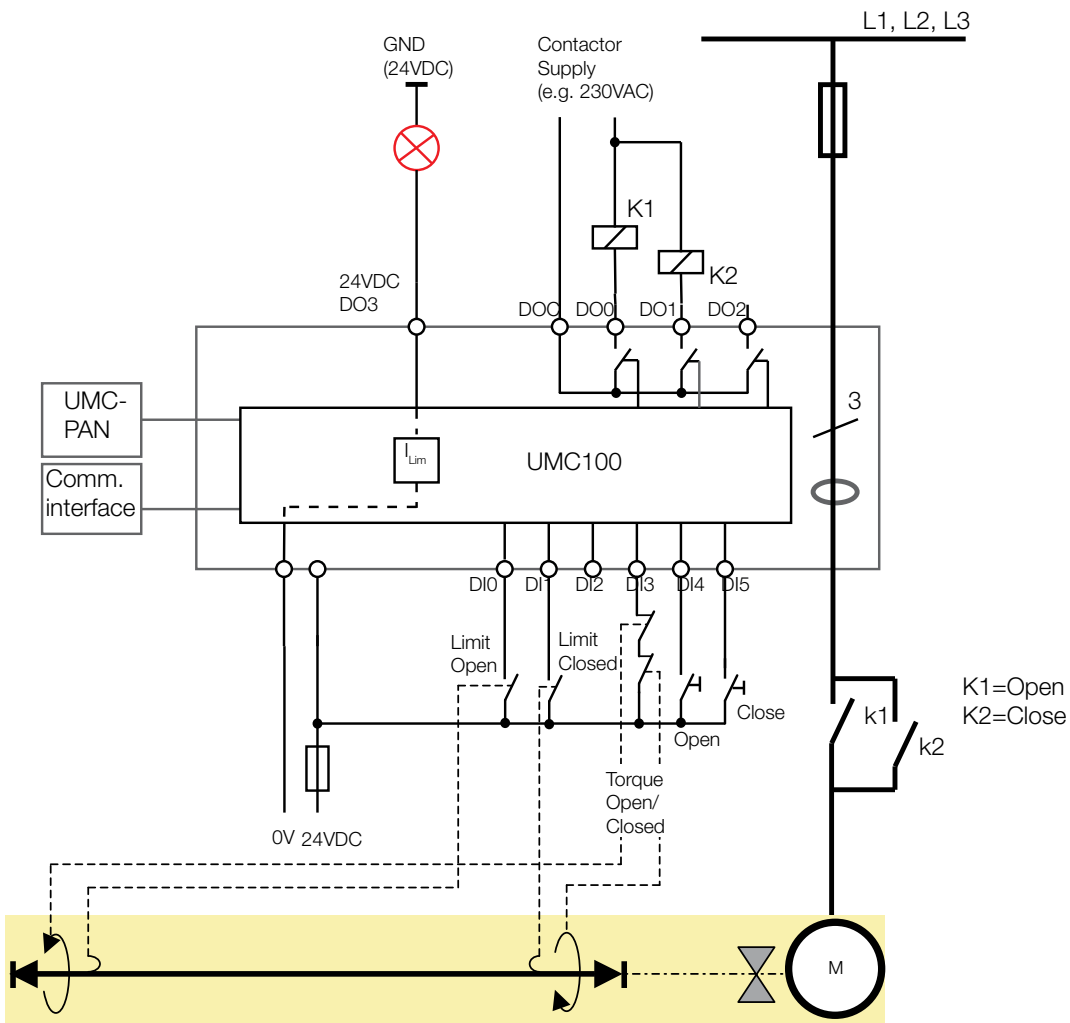

Control function = Actuator 2 (Basic circuit)

The control functions Actuator 1, 2, 3 and 4 provide different use of and reaction to the limit switches “Closed” and “Open” as well as the torque switches. The switches must be connected in a predefined manner to DI0, DI1 and DI3.

Optionally terminals named 24VDC Out (12) or DO2 can be used as a fault output

Overview:

Control function	Open <-> Closed			
	Torque open	Limit open	Limit closed	Torque closed
Actuator 1	-	Stop	Stop	-
Actuator 2	Stop	Prepare	Prepare	Stop
Actuator 3	-	Stop	Prepare	Stop
Actuator 4	Stop	Prepare	Stop	-

Actuator 1

Open and Closed position via limit switches

Usage with limit switches

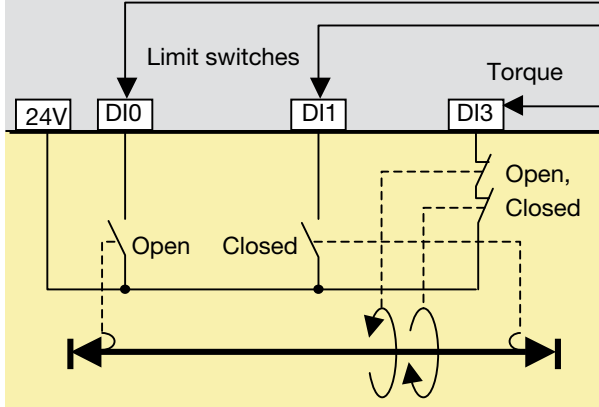

DI0: Motor off, start only in Closed direction
 DI1: Motor off, start only in Open direction
 DI3: Fault: motor stops

Remark

- Torque signals are not necessary but can be used for surveillance.
- After switching off the motor continues to run for some milliseconds due to its rotating mass. Adjustment of the Closed and Open limit switches is necessary to achieve the correct end positions.

Usage without torque switches

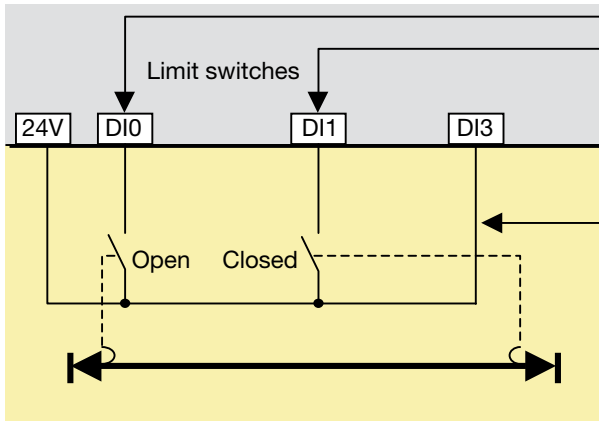

DI0: Motor off, start only in Close direction
 DI1: Motor off, start only in Open direction

Remark

Connection if torque contacts are not available

Actuator 2

Open and Closed position via torque and limit switches

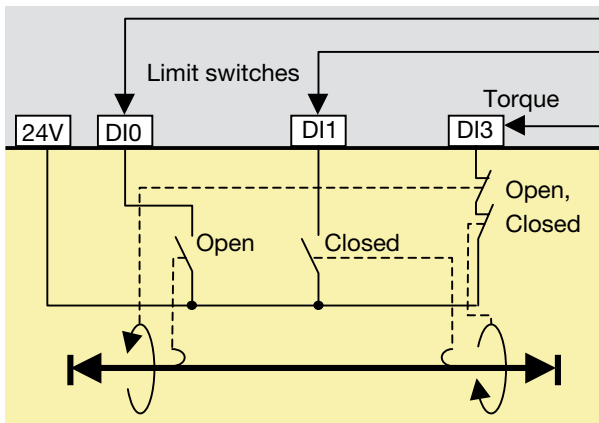

2CDC 342 020 F0206

*) Start is only possible in the opposite direction after resetting the fault. The torque signal has to disappear within 0.5 s otherwise a fault is generated again.

- DI0: Preparation for Open limit motor off
- DI1: Preparation for Closed limit motor off
- DI3: • Motor off, start only in opposite direction
- Fault if not prepared*

Remark

- The limit switches Open or Closed prepare the stop. Torque Open or Closed stops the motor. Starting is only possible in the opposite direction.
- The single torque signals in the telegram - torque Open or torque Closed - are calculated based on the direction of movement before the stop.
- If after powering up a torque signal is detected and neither an Open nor a Closed limit is present it is presumed that the torque occurred during closing. The start is possible only after fault acknowledgement and only in the opposite direction.

Actuator 3

Open position via limit switch only, Closed position via torque and limit switches

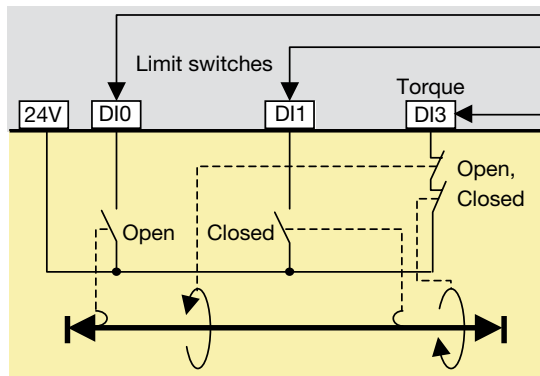

2CDC 342 021 F0206

- DI0: Motor off, start only in Closed direction
- DI1: Preparation for Closed limit off
- DI3: • Motor off if prepared for Closed limit motor off, start only in Open direction
- Fault if not prepared*

Remark

- The limit switch Open prepares the stop. Torque Open stops the motor. Starting is only possible in the opposite direction
- The single torque signals in the telegram - torque open or torque closed - are calculated based on the direction of movement before the stop.

Actuator 4

Open position via torque and limit switches, Closed position via limit switch only

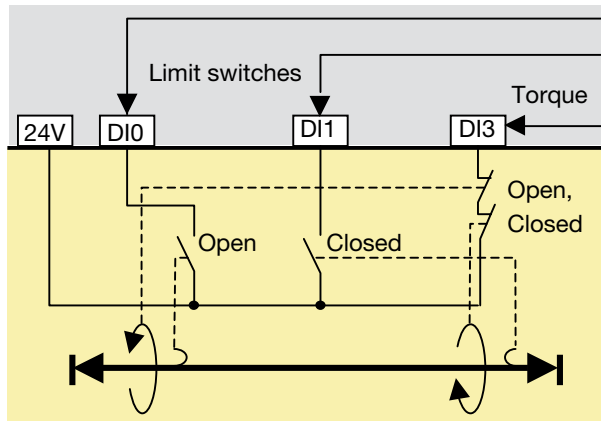

- DI0: Preparation for Open limit motor off
 DI1: Motor off, start only in Open direction
 DI3: • Motor off if prepared for Open off, start only in Closed direction
 • Fault if not prepared or if during closing

Remark

- The limit switch Closed prepares the stop. Torque closed stops the motor. Starting is only possible in the opposite direction
- The single torque signals in the telegram - torque Open or torque Closed - are calculated based on the direction of movement before the stop.

Definitions and monitoring signals particular to the control functions Actuator 1,2,3 and 4

- Input signals: Open and Closed inputs are active signals, torque input is a closed loop signal.
- The two torque signals are connected in series. The discrete torque signal is created based on the previous direction of movement.

Remark

If DI2 is not needed as fault input it can be connected to the link between the torque contacts to find out which torque signal is active.

- Run-time Open <-> Closed: The Run-time limit (= Star-delta starting time) must be changed and should be set according to actuator data. Setting the Run-time limit = 1 s disables the supervision.
- Starting from Open or Closed: The limit switch has to open within the start monitoring time of 3 s. Exceeding the time results in the fault signal Open limit switch 1 -> 0 not occurring within 3 s after the Closed command. The start monitoring time can be extended.
- A faulty torque signal in the intermediate position sets the internal fault signal. The motor is stopped and can be started again
 - after fault reset via fieldbus or other - AND -
 - only in the opposite direction (previous direction is blocked).

After starting the torque signal must disappear within 0.5 s. Otherwise the internal fault signal is set again. A fault reset and start in the opposite direction can be repeated as often as desired.

- If after powering up a torque signal (0-signal) is present and neither an Open nor a Closed signal is present it is presumed that the torque occurred during closing. The motor can be started:
 - after fault reset via fieldbus or other - AND -
 - only in the Open direction

Monitoring Data for Actuator 1 - 4

Word	Byte	Bit 7	Bit 6	Bit 5	Bit 4	Bit 3	Bit 2	Bit1	Bit 0
0	0	Summary Warning	Summary Fault	Local Control	Reverse Lockout Time	Overload warning	Opening	Off	Closing
	1	UMC100 DI5	UMC100 DI4	UMC100 DI3	UMC100 DI2	UMC100 DI1	UMC100 DI0	-	-
1	2, 3	Motor Current in % of I_e (0 % - 800 %)							
2	4, 5	Remaining data see chapter "11 Parameters and Data Structures on a Fieldbus"							
3	6, 7								
4	8, 9								
5	10,11								
6	12								
7	13								
	14								
	15								



The table above represents the data allocation as realised with the built-in standard applications. It may differ for customer-specific applications!

Command Data for Actuator 1 - 4

Word	Byte	Bit 7	Bit 6	Bit 5	Bit 4	Bit 3	Bit 2	Bit1	Bit 0
0	0	-	Fault Reset	Auto Mode	Prepare Emergency Start	-	Opening	Off	Closing
	1	UMC100 DO2 ¹⁾	-	-	UMC100 24VDC Out ¹⁾	-	-	-	-
1	2	Remaining data see chapter "11 Parameters and Data Structures on a Fieldbus"							
	3								
2	4, 5								
3	6, 7								

¹⁾ Controlled by UMC100 if configured as fault output.



The table above represents the data allocation as realised with the built-in standard applications. It may differ for customer-specific applications!

Control Function Softstarter

Use this function to control a softstarter. The UMC acts as communication interface for the softstarter.



The following protection functions are not active during ramp-up and ramp-down:

- Frequency out of range
- Unbalance
- Phase loss
- Internally calculated ground fault

During ramp-up and ramp-down and a connected voltage module the power and cos-phi values are invalid.

The control function softstarter must not be used for ATEX applications.

- Check-back supervision must be set to "Current"
- Relay output DO0 is used by the control function to activate the forward contactor
- Relay output DO1 is used from the control function to activate the reverse contactor
- Relay output DO2 provides the start/stop signal for the softstarter
- DI0 is used as ramping information for the UMC in case a Softstarters provides this signal (see below)
Set multifunction input DI0 to "Off". It must not be configured for any other function in this case.
- Optionally DI3 / DI4 can be used to start the motor and DI5 to stop the motor
- Optionally DO3 can be used as a fault output

For softstarters without by-pass signal it is necessary to configure a ramp-up time. After this time the UMC assumes the ramp-up to be finished and protection functions listed in the box above are activated again. To configure the ramp-up time use the YD-Starting-Time parameter. A value < 3600 seconds must be set. After the start command the UMC immediately closes the main contactor but awaits an additional delay (parameter Delay1) till the start command is signalled to the softstarter.

Stopping: After the stop signal the UMC immediately opens DO2 to signal the stop to the softstarter. The UMC detects the end of the ramp-down phase automatically by monitoring the motor current ($I < \text{below lower measurement range}$).

Check back supervision must be set to "Motor current" for that reason. After ramp-down was detected an additional delay (parameter Delay 2) is awaited until the forward or reverse contactor is opened.

Checkback delay time has to be configured equal or larger than the time configured for Delay 1 or Delay 2. Delay 1 and delay 2 are predefined but can be changed using the custom application editor.

Softstarters providing a ramping signal it is recommended to use this signal and connect it to digital input DI0 of the UMC. The Multifunction Input 0 must be set to Off in this case.

The parameter YD-Starting-Time must be set to 3600 seconds in this case.

Monitoring Data for Softstarter

Word	Byte	Bit 7	Bit 6	Bit 5	Bit 4	Bit 3	Bit 2	Bit1	Bit 0
0	0	Summary Warning	Summary Fault	Local Control	Reverse Lockout Time	Overload warning	Run Forward	Off	Run Reverse
	1	UMC100 DI5	UMC100 DI4	UMC100 DI3	UMC100 DI2	UMC100 DI1	UMC100 DI0	-	-
1	2, 3								
2	4, 5								
3	6, 7								
4	8, 9								
5	10,11	Remaining data see chapter "11 Parameters and Data Structures on a Fieldbus"							
6	12								
	13								
7	14								
	15								



The table above represents the data allocation as realised with the built-in standard applications. It may differ for customer-specific applications!

Command Data for Softstarter

Word	Byte	Bit 7	Bit 6	Bit 5	Bit 4	Bit 3	Bit 2	Bit1	Bit 0
0	0	-	Fault Reset	Auto Mode	Prepare Emergency Start	-	Run Forward	Off	Run Reverse
	1	-	-	-	DO3 (24VDC) ¹⁾	-	-	-	-
1	2	Remaining data see chapter "11 Parameters and Data Structures on a Fieldbus"							
	3								
2	4, 5								
3	6, 7								

¹⁾ Controlled by the UMC100 if configured as fault output.



The table above represents the data allocation as realised with the built-in standard applications. It may differ for customer-specific applications!

Timing Diagram

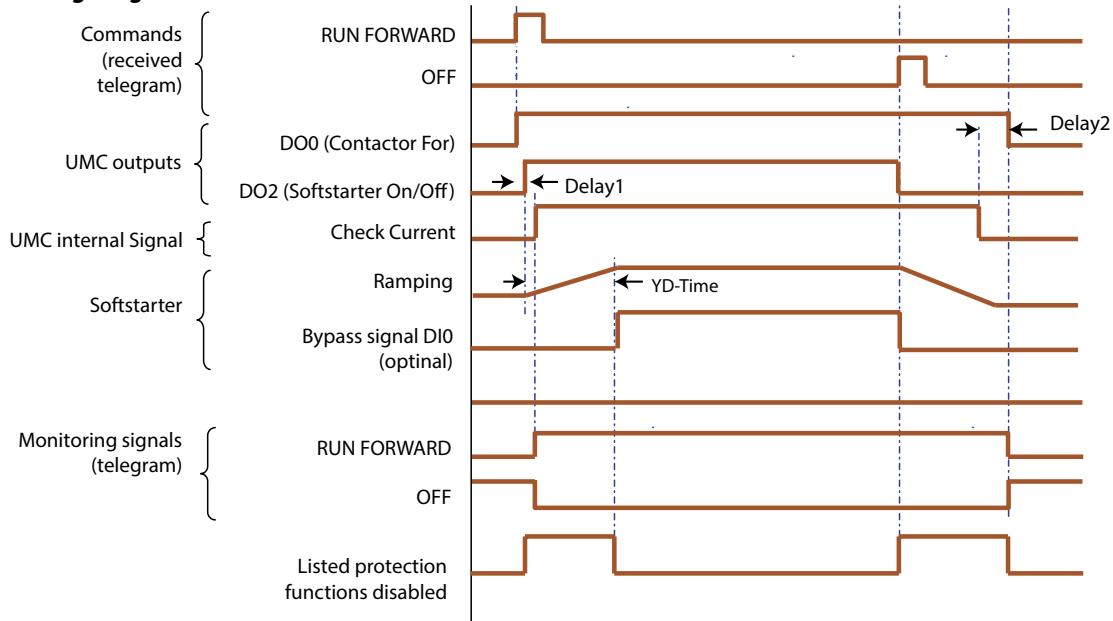

- Opposite direction only possible after OFF and after the reverse lock-out time has elapsed.
- Restart in the same direction without consideration of the Reverse lock-out time.

Related parameters

- Reverse Lockout Time
- YD-Starting-Time (used as ramp-up time if no by-pass signal available)
- Delay 1 / Delay 2 (default value set, can be changed only in the custom application editor)
- Checkback delay time
- Checkback

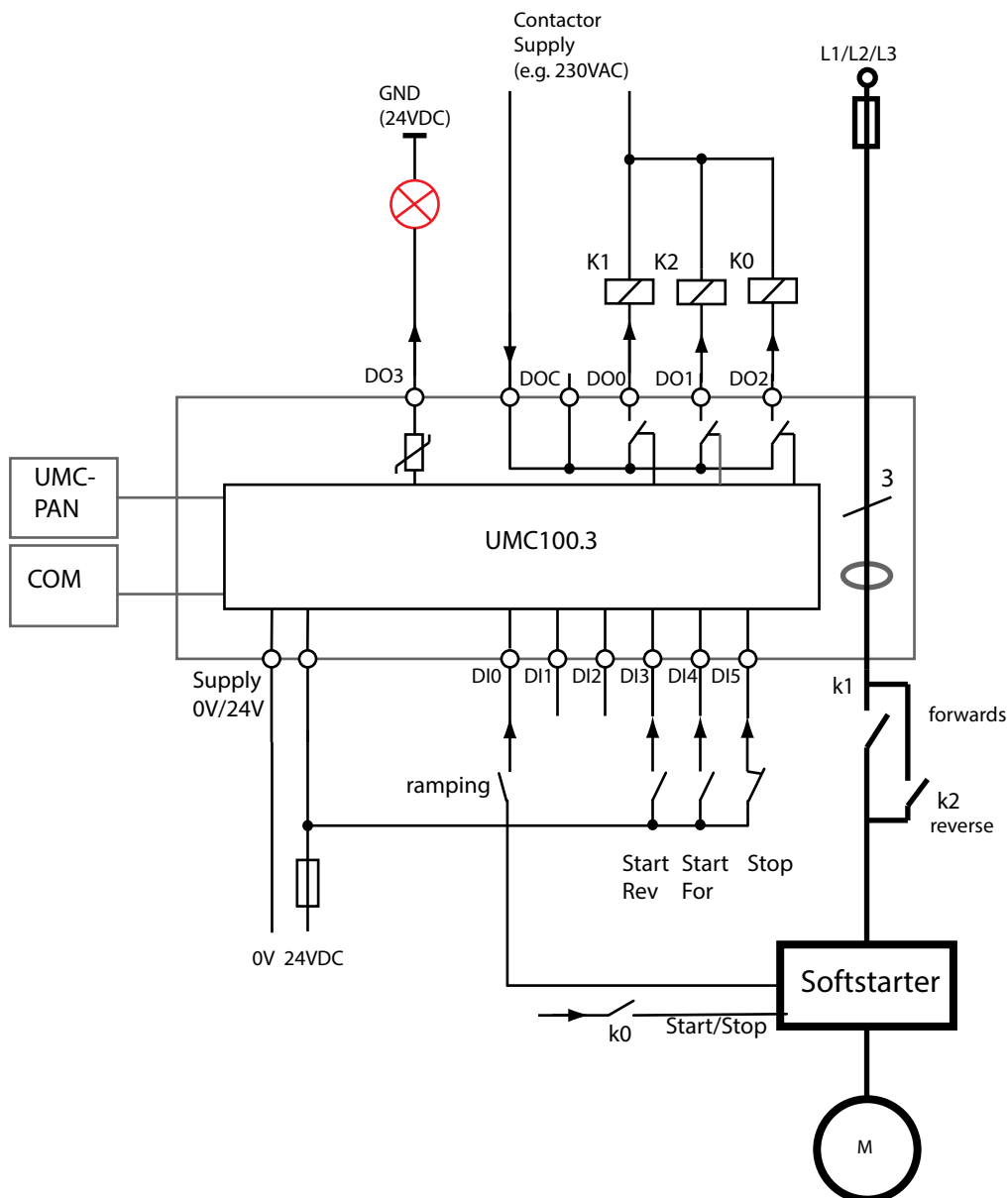

—
Circuit diagram of the UMC for controlling a softstarter in two directions of rotation.
The start/stop buttons on DI3 ... DI5 are optional. See explanations in the text about the
ramping signal

Controlling Resistive Loads

Consider the following points to monitor and control resistive loads e.g. heat tracings. No real control function is described here but an operation mode that can be used together with other control functions. To activate this mode set parameter "Resistive Load" to "YES".

Usage examples

- Heat Tracing: To monitor and switch on/off a three phase heat tracing use the control function DOL
- Load Feeder: To just monitor the current or active power in the three phases use the transparent control function. For single phase loads set also the parameter "Number of Phases".

Tripping behavior

- Set parameter "Nominal current" always to the highest current in the three phases. Otherwise the thermal overload protection might create a trip. Set the parameter "Trip Class" to "Class 40".
- The implemented thermal model follows the figure in chapter "13 Technical data". UMC100.3 is designed as a protection device for 3-phase AC induction motors. It is not approved for thermal cable and short circuit protection.
- The cooling function is adjusted to motors.
- In the mode "resistive loads" always the highest current of the 3 phases is input of the thermal model. One common thermal model for the 3 phases is implemented, which is fed with the highest present current of L1, L2 or L3.
- Then protection functions high / low current trip and warning always use the highest current of the 3 phases.

Restrictions for power calculation of resistive loads

The phase angle φ must always be $\geq 0^\circ$; no capacitive load allowed. Otherwise the results of power calculation are not specified. Currents must be in Sine wave form. Other wave forms caused by e.g. switching loads can lead to wrong calculations of current, voltage and power.

Symmetrical network / voltages, so that calculation from 3-phase line to line back to single phase voltages (division by 3rd root) is possible. Imbalance increase the deviation in calculation of voltage and power.

Active power is calculated as follows:

$$P_w = (I_{L1} + I_{L2} + I_{L3}) * (U_{L1L2} + U_{L2L3} + U_{L3L1}) / 3 * PF / \sqrt{3}$$

- In the UMC100.3 the power factor is calculated as follows:

$$PF = \cos((\text{abs} \angle I_{L1} U_{L1} + \text{abs} \angle I_{L2} U_{L2} + \text{abs} \angle I_{L3} U_{L3}) / 3)$$

Remark

If the $\cos\varphi$ in each phase is identical, this $\cos\varphi$ match the power factor (active power / apparent power)

Helpful suggestions:

- Set parameter "check phase sequence" = off
- Set parameter "phase loss protection" = off; --> current imbalance protection is also disabled.

Current imbalance calculation is always available: $I_{imb} = 100 * (1 - I_{min} / I_{max})$.

Remarks

- No ATEX certificate for this application.

6 Configuring the Communication Interfaces

The UMC can be integrated into different fieldbus and Ethernet networks with the help of a communication interface. Communication interfaces exist for PROFIBUS DP, PROFINET IO, DeviceNet, Modbus RTU, ModbusTCP and EtherNet/IP™. Since the communication networks and the various communication master configuration tools are very different no common integration procedure can be described here. In general the following generic steps are usually necessary:

1. Make the UMC known to the engineering tool e.g. by importing the device description file (GSD, GSDML, EDS)
2. Create a network and insert nodes like the UMC as required
3. Set the UMC parameters according to your needs (if parameterisation from within the system is required)
4. Make the I/O signals available in your programming tool (e.g. a IEC61131 based tool)

To use the UMC in a fieldbus network the following parameters should be considered.

Setting the Bus Address

The bus address can be adjusted with the UMC LCD panel. The UMC allows an address to be set between 000 and 255. But there are different limitations depending on the fieldbus in use. Setting the address to 255 means that the UMC will take over the address from a connected communication interface.

- PROFIBUS: 2 ...125
- DeviceNet: 2 ... 64
- Modbus: 2 ... 125.



Ensure that the chosen bus address is not used twice. If an address is used twice the whole bus line might go out of operation.

Relevant parameter: Bus Address

Specific Communication Settings for Modbus RTU and DeviceNet

For the Ethernet modules PNQ22.0 for PROFINET and MTQ22.0 for ModbusTCP also a bus address has to be set for each configured port. But this address is only for the "Address Check" feature described in the section below to identify if the right UMC100.3 is connected.

The EtherNet/IP™ module EIU32.0 uses the last octet of the IP address for identification, and the connected UMC100.3 needs to be set to the same address. Generally Ethernet devices use TCP/IP address for node addressing.

Relevant parameter:

- Address Check
- DeviceNet baudrate
- MODBUS baudrate
- MODBUS frame
- MODBUS bus timeout

Specific Communication Settings for Ethernet

For single Ethernet interfaces like EtherNet/IP™ EIU32.0 there are additional settings

- IP setting mode DHCP, Basic, User defined
- IP address octet 1, 2, 3, 4
- Subnet mask octet 1, 2, 3, 4
- Gateway octet 1, 2, 3, 4
- Enable webserver On, Off

Address Check when using UMC in Motor Control Centres

If the UMC is used in MCCs the address check can be enabled. This ensures that the bus address in the communication interface and the UMC must match before the bus communication can start. This ensures that in the event of an unintentional permutation of a drawer the bus address stays in place and does not move with the drawer. A precondition for this function is the separation of communication interface and UMC. In MCCs the communication interface is usually mounted in the cable chamber whereas the UMC is mounted in the withdrawable unit. This means that even if the withdrawable is removed the communication interface stays active, keeps the bus address and can send an error message (missing device) to the control system.

The following cases can occur:

1. Neither the UMC100.3 nor the communication interface contains a valid address (i.e. 255): The UMC does not start to communicate.
2. Only the UMC100.3 contains a valid address (i.e. 255): The communication interface receives the address and saves it. Then the bus communication starts automatically.
3. Only the communication interface contains a valid address (e.g. a new spare UMC is connected which has 255 as address). The UMC gets the address from the communication interface and saves it. Then the communication starts.
4. The UMC100.3 and the communication interface contain the same address: Operation and communication starts. The UMC100.3 and the communication interface contain different addresses (e.g. unintentional permutation when installing a drawer): The behaviour of the UMC100.3 depends on the setting of the parameter Address check.

Case 5a: Address check = Off (= 0) (default)

The communication interface stores the address received from the UMC100.3 and communication starts.

Case 5b: Address check = On (1)

- The communication does not start. In the LCD control panel an address fault is displayed

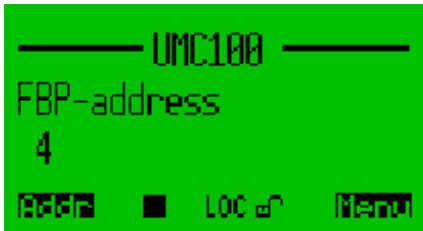

- To start the bus communication the correct address (i.e. the one from the communication interface must be selected in the UMC100.3
- Enter the fault menu with the left hot-key (Addr)



- Click "Fix" (right hot-key) to select the communication interface bus address
- After saving the corrected bus address the communication starts immediately
- Both the communication interface and the UMC100.3 store the adjusted address.

Relevant parameter:

- Address Check

Defining the Bus Fault Reaction

Depending on the application the UMC is used in you might configure the reaction to a bus fault in a different way. The bus fault reaction can be set the following way:

- Retain the present state (either running or stopped)
- Stop the motor immediately
- Start the motor in a forward direction (if actually in stop mode). If it is already running in a reverse or a forward direction the motor keeps running.
- Start the motor in a reverse direction (if actually in stop mode). If it is already running in a reverse or a forward direction the motor keeps running.

Relevant parameter:

- Bus Fault Reaction

Ignore Block Parameters

Block parameters can be used to parameterise a device from within the PROFIBUS master using the GSD file. The PROFIBUS master then sends the parameters in one block (this where the name came from) to the device. The block parameters are sent under certain conditions:

- Bus master start-up
- Device start-up
- During normal operation in case of parameter changes

If the UMC shall be parameterized via LCD panel or using the FIM UMC Edition software, the block parameters should not be sent. As it is not possible to prevent the bus master from sending the block parameters the PROFIBUS communication interfaces can be configured to stop forwarding these parameters to the UMC (i.e. ignore them).

To do so set parameter "Ignore Block Parameter" to "Ignore".



A typical customer error message, if this parameter was not set, is as follows: "We set up everything correctly and the plant worked for weeks without problems. But then suddenly the UMC lost its parameters."

What happened: The UMC was configured e.g. via LCD panel during commissioning. Then weeks later the bus master or controller was restarted for whatever reason and therefore sent the default UMC block parameters as they were never set.

If you are unsure if the parameter was set correctly you can also lock the parameters in the UMC. Then no parameter changes are possible anymore until the lock is reset. If locked the small "lock" icon  appears in the LCD display.

Relevant parameter:

- Ignore Block Parameters

Change I/O data length on the fieldbus

For some process control systems the I/O data size is limited, e. g. to 255 bytes for all slaves.

As a consequence only a small number of UMCs can be connected to such a fieldbus master.

In a situation like this, the I/O data size can be reduced to a lower value which allows to connect more UMCs to the network. The UMC simply cuts the data length as shown in chapter "11 Parameters and Data Structures on a Fieldbus".



For Profibus I/O-Data-Profile 2 can be selected in the Profibus configuration, it is part of the standard GSD.

For DeviceNet a special EDS file is available.

Take care that in these cases the UMC100.3 must be set also to Profile 2 via control panel or FIM configuration software.

When changing a UMC100.3 (drawer or spare part), this setting needs to be done again, it is not automatically downloaded.

Adjust cyclically transmitted Monitoring Words

By default the cyclically transmitted monitoring words are predefined as in the previous versions of UMC100.3 (e.g. first word contains the motor current in % of I_e). But depending on the connected expansion modules or special application needs it is possible to adjust the transmitted analog monitoring words with the help of the parameters listed below.

Relevant parameters:

- Param To PV 1/2/3/4/5

Special considerations for backwards compatibility on DeviceNet and PROFINET

The UMC100.3 is fully backwards compatible with UMC100-FBP.

To replace a UMC100-FBP with UMC100.3 without changing the device description files in a bus master it is necessary to adjust the parameter "Retrofit" to "UMC100-FBP" using the LCD operator panel.

Relevant parameter:

- Retrofit

7 Using Expansion Modules

In this chapter you learn how to use the UMC expansion modules. Expansion modules allow you to increase the number of inputs and outputs. For information on how to connect the IO modules to the UMC read chapter "2 Installation". The IO module's status messages are described in chapter "9 Error Handling, Maintenance and Service".

Using a Digital IO Module (DX111.0/122.0)

To activate a digital IO module set parameter DX1xx.0 Enabled to On. If a module is enabled the UMC monitors the presence of the module and creates by default a fault in the event that the module is missing (-> parameter 'Missing Module Reaction').

Using the Digital Inputs

By default all eight digital inputs are available in the fieldbus monitoring telegram. They can thus be directly used in the PLC/DCS application.

For inputs 1DI0 to 2DI5 the following additional options exist:

- Each input can separately trigger a fault or warning with a unique error code and error message that is shown on the UMC's LCD panel.
- A fault can be automatically cleared when the cause of the fault is rectified.
- Each input can optionally be delayed. (see parameter DX1xx.0 DI delay for details)

The following figure shows the internal data flow of the inputs 1DI0 - 2DI5.

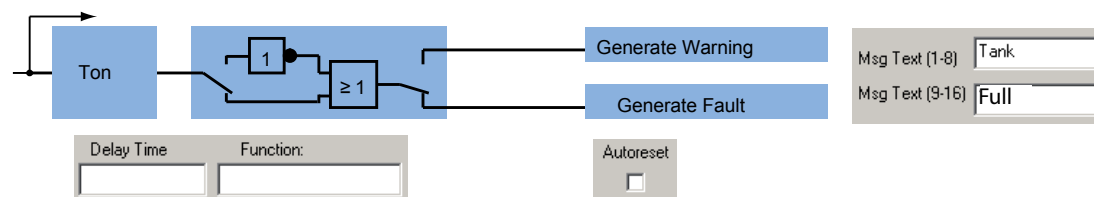

Functionality of the six digital inputs 1DI0 - 2DI5 of the DX111.0 and DX122.0 modules

Internally the digital inputs of the DX1xx module are connected to a function block called 'AuxFaultWarn' with six inputs called Aux1 to Aux6. The following table shows which IO module input relates to which parameter set:



DX1xx input	Parameters	DX1xx Input	Parameters
1DI0	Aux. Inp. 1	1DI4	Aux. Inp. 5
1DI1	Aux. Inp. 2	2DI5	Aux. Inp. 6
1DI2	Aux. Inp. 3	-	-
1DI3	Aux. Inp. 4	-	-

Using the Relay Outputs

The 4 relay outputs are connected to the fieldbus command telegram and can be freely used by the control system. By default they are not used by the UMC in any way. See the fieldbus command telegram for the relevant bit positions.



The inputs and outputs of the modules DX122.0 and DX111.0 can be freely used in the Custom Application Editor. Consult the editor's manual if you plan to use the inputs or outputs directly in the UMC.

Using the Analog Output

The analog output can be used to drive an analog instrument to e.g. display the motor current. It can work in the following modes: 4-20 mA, 0-20 mA, 0-10 V

Relevant Module Parameters:

- DX1xx.0 Enabled
- Aux. Inp 1 - 6 Delay
- DX1xx.0 DI Delay (Delay for all inputs)
- Analog Out0 Type
- Analog Out0 Error Reaction
- Aux. Inp 1 - 6 Acknowledge Mode
- Aux. Inp 1 - 6 Reaction
- Aux. Inp 1 -6 Message Line 1 / Line 2
- Missing Module Reaction

Using a Voltage Module (VI150.0/155.0)

Activating a Voltage Module (VI150.0/155.0)

To activate the voltage module set parameter VI15x.0 Enabled to On. If a module is enabled the UMC monitors the presence of the module and triggers by default a fault in the event that the module is missing (-> parameter Missing Module Reaction).

Before the voltage module can be used the parameters listed below must be adjusted. For the voltage based protection parameters see chapter 4, section "Voltage and Power Protection Functions".

Using the Relay Output

The relay output is connected to the fieldbus command telegram and can be controlled from the control system. See the fieldbus command telegram for the relevant bit position. By default it is not used by the UMC in any way. But it can be used in a customer specific function block application.



The relay output of the modules VI15x.0 can be freely used in the Custom Application Editor. Consult the editor's manual if you plan to use the output directly in the UMC.

Relevant Module Parameters:

- VI15x.0 Enabled
- Nominal Line Voltage
- Nominal power factor (cos phi)
- Number of phases
- Missing Module Reaction

Using an Analog Input Module (AI111.0)

To activate the analog module set parameter AI111.0 Enabled to On. If a module is enabled the UMC monitors the presence of the module and triggers by default a fault in the event that the module is missing (-> parameter Missing Module Reaction). See chapter 4, section "RTD based Temperature Supervision and Analog Inputs" for more information about the protection and monitoring functions based on the AI111.0.

Relevant Parameters for the AI111 module

- AI1xx.0 AM1/2 enabled
- AM1/2 mode
- AM1/2 CH1 type
- AM1/2 CH1 err reac
- Dip Autorestart Enable
- AM1 Tmax trip level
- AM1 Tmax warn level
- AM1 Tmax delay
- LCD Panel Temperature Unit

8 The LCD Control Panel UMC100-PAN

Overview

The UMC100-PAN provides an easy to use multi-language user interface for the UMC100.3. In this chapter you will find the following information:

- menu structure
- how to operate the UMC100.3 with the LCD panel
- how to acknowledge faults
- how to watch process data
- how to configure the UMC100.3 using the LCD panel
- how to use the LCD panel as parameter storage (e.g. for backup purposes)
- how to use the LCD panel as automatic parameter backup storage

See the "Installation" chapter if you are looking for information on how to connect and wire the LCD panel.

The UMC100-PAN can be either plugged directly on the UMC or mounted on the switchgear door using the door mounting kit. The following diagram shows the LCD panel with its buttons, LEDs and LCD area.



This chapter describes how the parameters can be accessed from the UMC100-PAN. Please look into chapter "11 Parameters and Data-Structures on a Fieldbus" for an explanation of the parameters.

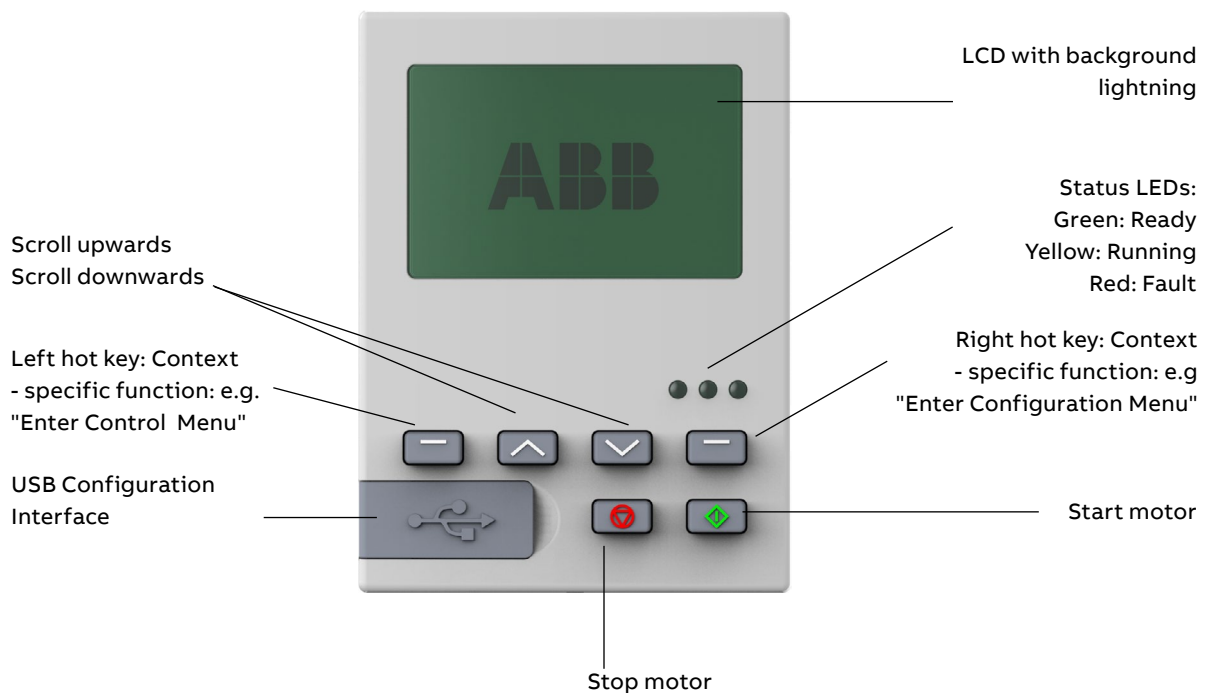

Monitoring Status Information

On the top level of the menu tree which is entered after powering on, several information masks show the overall status of the UMC and connected IO. To switch between the different masks, use the scroll up or scroll down keys. The LCD is split into the following different logical areas:

- Header: At the top of the LCD the tag name or the submenu title is shown.
- Main Area: Main display area to display process data or configuration data etc.
- Icon Line: At the bottom of the LCD the actual function of the hot keys (left / right) is shown. In the middle further status information is displayed as icons. The table below shows the different icons and their meaning.

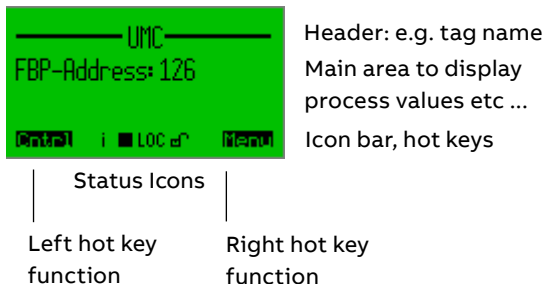

Icon	Meaning
i	Warnings available. Go into submenu Maintenance/Service->Diagnosis->Present Warnings to find out the reason for the warning.
■	Motor stopped
▶, ▶▶	Motor running forwards / fast forward
◀, ◀◀	Motor running backwards / fast backwards
LOC	Local control mode 1/2 active
REM	Remote (auto) control mode active
🔒	Parameters unlocked / locked: If parameters are locked (indicated with the closed lock in the icon bar) they cannot be changed either by the fieldbus or using the panel. To change parameters you have to unlock them first. If password protection is enabled the password has to be typed in first before a parameter can be changed.
°C	Cooling time running. Motor cannot be started until the cooling time is over.
t	1) Reverse lockout time is running. 2) The motor cannot be started in opposite direction until the reverse lockout is over. 3) The pause time of the number of start limit function is running
💾	Auto save enabled

Pressing the up/down keys brings you to the next/previous menu on the same level. Pressing Menu enters the first menu level. Pressing Cntrl brings you into the motor control menu.

The figure on the next page shows the top level menu structure and the main configuration menu.

The Menu Tree

If you press **Menu** you enter the main configuration menu. The parameters are organised into groups as described in the chapter "11 Parameters and Data Structures on a Fieldbus->Parameter Organisation" and as shown in the diagram on the following page. The scroll bar on the right indicates the present location in a configuration menu with several menu items. On the top of the mask the active menu name (parent menu) is shown.

Masks on the top level and the main configuration menu masks.

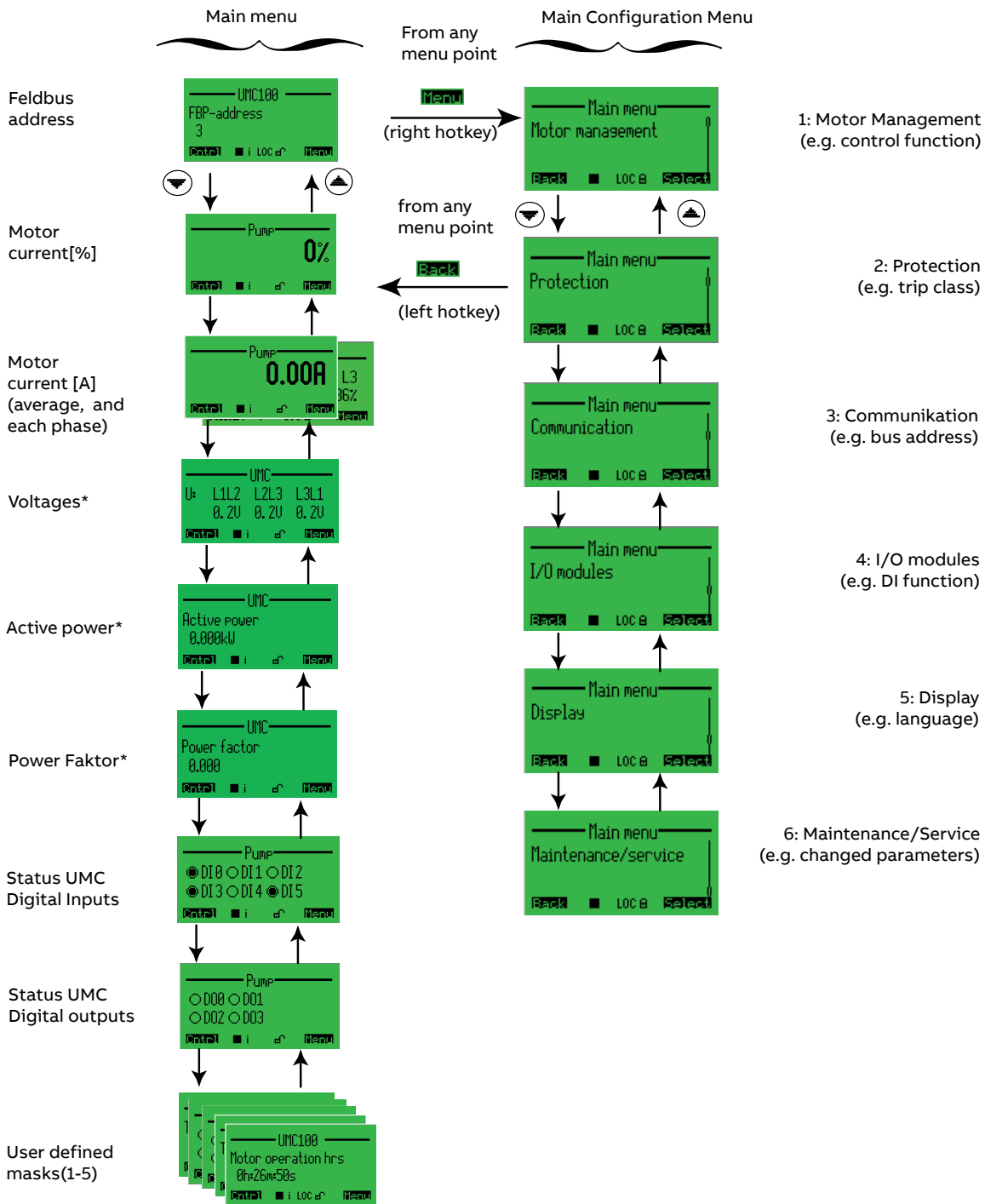

With the right soft key **Select** you can enter the selected submenus which are described in the following sections. The masks shown with a star * are only displayed if the voltage module is present.

Motor Management Parameters

Within this submenu all motor management related parameters can be configured.
The diagram below shows the organisation of the different parameter masks in the menu tree.

 The parameters are described in details in the chapter "11 Parameters and Data Structures on a Fieldbus -> Parameter Organisation-> Motor Management Parameters". A description of the parameters of the menu entry "Auxiliary inputs" can be found in the chapter "11 Parameters and Data-Structures on a Fieldbus->Parameter Organization-> Function Block Related Parameters".

1	Motor Management	1.9	Local control mode 1	1.11	Local control mode 2
1.1	Control function	1.9.1	Loc1 start bus cyc.	1.11.1	Loc2 start bus cyc.
1.2	Reverse lockout time ¹	1.9.2	Loc1 stop bus cyc.	1.11.2	Loc2 stop bus cyc.
1.3	YD changeover mode ²	1.9.3	Loc1 start LCD	1.11.3	Loc2 start LCD
1.4	YD starting time ²	1.9.4	Loc1 stop LCD	1.11.4	Loc2 stop LCD
1.5	Time limit actuator ³	1.9.5	Loc1 start bus acyc.	1.11.5	Loc2 start bus acyc.
1.6	Fault output	1.9.6	Loc1 stop bus acyc.	1.11.6	Loc2 stop bus acyc.
1.7	Checkback	1.9.7	Loc1 start DI	1.11.7	Loc2 start DI
1.8	Inching DI start input	1.9.8	Loc1 stop DI	1.11.8	Loc2 stop DI
1.9	Local ctrl mode 1				
1.10	Auto ctrl mode	1.10	Auto ctrl mode	1.13	Multifunction inputs
1.11	Local ctrl mode 2				
1.12	Invert ctrl inputs	1.10.1	Auto start bus cyc.	1.13.1	Multifunction 0
1.13	Multifunction inputs	1.10.2	Auto stop bus cyc.	1.13.2	Multifunction 1
1.14	Enable custom logic	1.10.3	Auto start LCD	1.13.3	Multifunction 2
1.15	Limit number of starts	1.10.4	Auto stop LCD	1.13.4	Multif. 0 delay
1.16	Extended	1.10.5	Auto start bus acyc.	1.13.5	Multif. 1 delay
1.17	Resistive load	1.10.6	Auto stop bus acyc.	1.13.6	Multif. 2 delay
1.18	Number of phases	1.10.7	Auto start DI	1.13.7	Multif. 0 autoreset
1.19	Warnlevel oper.hours	1.10.8	Auto stop DI	1.13.8	Multif. 1 autoreset
1.20	Warnlev standstill h			1.13.9	Multif. 2 autoreset
		1.16	Extended	1.13.10	Multif. 0 fault text L1/2
		1.16.1	Emergency start	1.13.12	Multif. 1 fault text L1/2
		1.16.2	Fault auto reset	1.13.14	Multif. 2 fault text L1/2
		1.16.3	Custom app parameter		
		1.16.4	Param to PV 1	1.12	Invert ctrl inputs
		1.12.1	Invert DI start inp.
		1.16.8	Param to PV5	1.12.2	Invert DI stop inp.
		1.16.9	Check-Back Time		
		1.16.10	Auxiliary inputs	1.15	Limit num of starts
		1.16.10	Auxiliary inputs	1.15.1	Num starts allowed
		1.16.5.1	Aux inp 1 ack mode	1.15.2	Num starts window
		1.16.5.2	Aux inp 1 reaction	1.15.3	Num starts pause
		1.16.5.3	Aux inp 1 delay	1.15.4	Num starts overrun
		1.16.5.4	Aux inp 1 message L1	1.15.5	Num starts prewarn
		1.16.5.5	Aux inp 1 message L2		
		...	(Same repeats for Aux 2 ... 6)		

1) Only for control function REV
2) Only for control function YD
3) Only for control function Actuator

Motor Protection Parameters

Within this submenu all motor protection related parameters can be configured.

The diagram below shows the organisation of the different parameter masks in the menu tree.

 The parameters are described in detail in the chapter "11 Parameters and Data Structures on a Fieldbus->Parameter Organisation-> Motor Protection Parameters".

2	Protection	2.9	Locked Rotor	2.15	Over / under voltage
2.1	Setting Ie 1	2.9.1	LR trip level	2.15.1	U low trip level
2.2	Setting Ie 2*	2.9.2	LR trip delay	2.15.2	U low trip delay
2.3	Trip class			2.15.3	U low warn level
2.4	Current factor	2.11	Phases	2.15.4	U low warn delay
2.5	PTC	2.11.1	Phase loss protect.	2.15.5	U high trip level
2.6	Cooling mode	2.11.2	Phase imb. trip lev.	2.15.6	U high trip delay
2.7	Cooling time	2.11.3	Phase imb. warn lev.	2.15.7	U high warn level
2.8	Restart level %	2.11.4	Phase reversal	2.15.8	U high warn delay
2.9	Locked rotor (LR)	2.11.5	Check phase sequence		
2.10	Thermal load warnlev	2.12	Over / under current	2.16	Voltage imbalance
2.11	Phases	2.12.1	Low curr trip level	2.16.1	U imb trip level
2.12	Over/under current	2.12.2	Low curr trip delay	2.16.2	U imb trip delay
2.13	Int. earthfault	2.12.3	Low curr warn level	2.16.3	U imb warn level
2.14	Voltage DIP**	2.12.4	Low curr warn delay	2.16.4	U imb warn delay
2.15	Over/under voltage**	2.12.5	High curr trip level		
2.16	Voltage imbalance**	2.12.6	High curr trip delay	2.18	Over / under power
2.17	Load startup delay**	2.12.7	High curr warn level	2.18.1	P low trip level
2.18	Over/under power**	2.12.8	High curr warn delay	2.18.2	P low trip delay
2.19	Power factor**			2.18.3	P low warn level
2.20	Power quality**	2.13	Int. earthfault	2.18.4	P low warn delay
		2.13.1	Earth flt. trip lev.	2.18.5	P high trip level
		2.13.2	Earth flt. trip delay	2.18.6	P high trip delay
		2.13.3	Earth flt. warn lev.	2.18.7	P high warn level
		2.13.4	Earth flt. warn delay	2.18.8	P high warn delay
		2.13.5	Earth fault detection		
		2.14	Voltage DIP	2.19	Power factor
		2.14.1	Enable voltage DIP	2.19.1	PwrFactor trip level
		2.14.2	Voltage DIP duration	2.19.2	PwrFactor trip delay
		2.14.3	Autorestart enable	2.19.3	PwrFactor warn level
		2.14.4	Autorestart window	2.19.4	PwrFactor warn delay
		2.14.5	Autorestart delay		
		2.14.6	DIP restart level	2.20	Power quality
		2.14.7	DIP level	2.20.1	THD warn level
				2.20.2	THD warn delay

*) Polechanging starter only

***) With voltage module only

Communication Parameters

Within this submenu all communication related parameters can be configured. The diagram below shows the organisation of the different parameter masks in the menu tree. The parameters are described in details in the chapter "11 Parameters and Data Structures on a Fieldbus->Parameter Organisation->Communication Parameters".

3	Communication	3.8	Ethernet
3.1	Address check	3.8.1	IP setting mode
3.2	Busfault reaction	3.8.2	IP address octet 1
3.3	Busaddress	3.8.3	IP address octet 2
3.4	Parameter lock	3.8.4	IP address octet 3
3.5	I/O Data Profile	3.8.5	IP address octet 4
3.6	DevNet baudrate	3.8.6	Subnet mask octet 1
3.7	MODBUS RTU	3.8.7	Subnet mask octet 2
3.8	Ethernet	3.8.8	Subnet mask octet 3
3.9	Extended	3.8.9	Subnet mask octet 4
3.7	Modbus RTU	3.8.10	Gateway octet 1
1.1	MODBUS baudrate	3.8.11	Gateway octet 2
1.2	MODBUS frame	3.8.12	Gateway octet 3
1.3	MODBUS bus timeout	3.8.13	Gateway octet 4
		3.8.14	Enable webserver
		3.9	Extended
		3.9.1	Retrofit

IO Module Parameters

Within this submenu all IO module related parameters can be configured. The diagram below shows the organisation of the different parameter masks in the menu tree. The parameters are described in details in the chapter "11 Parameters and Data Structures on a Fieldbus->Parameter Organisation->IO Module Parameters".

4	IO Modules	4.2	DX1xx	4.2.2	DX1xx settings
4.1	Missing module react.	4.2.1	DX1xx enabled	4.2.2.1	DX1xx DI delay
4.2	DX1xx¹	4.2.2	DX1xx settings	4.2.2.2	DX1xx AO type
4.3	VI15x²	4.2.3	DX1xx monitoring	4.2.2.3	DX1xx AO err reac.
4.4	AI1/2³	4.2.4	DX1xx HW + SW version	4.3.2	VI15x settings
1) Only shown if DX1xx is enabled 2) Only shown if VI1x is enabled 3) Only shown if AI1/2 is enabled		4.3	VI15x	4.3.2.1	Nominal line voltage
		4.3.1	VI15x enabled	4.3.2.2	Nominal power factor
		4.3.2	VI15x settings	4.3.2.3	Power scale factor
		4.3.3	VI15x monitoring	4.4.2/6	AI111
		4.3.4	VI15x HW + SW version	4.4._1	AMx mode
		4.4	AI111	4.4._2	AMx CH1 type
		4.4.1	AI1 enabled	4.4._3	AMx CH1 err reac
		4.4.2	AM1 settings	4.4._4	AMx Tmax trip level
		4.4.3	AM1 monitoring	4.4._5	AMx Tmax warn level
		4.4.4	AM1 HW + SW version	4.4._6	AMx Tmax delay
		4.4.5	AI2 enabled	4.4._7	AMx CH2 type
		4.4.6	AM2 settings	4.4._8	AMx CH2 err reac
		4.4.7	AM2 monitoring	4.4._9	AMx CH3 type
		4.4.8	AM2 HW + SW version	4.4._10	AMx CH3 err reac

Display Parameters

5	Display	5.13	Password protection
5.1	Language	5.13.1	Password enabled
5.2	Tag name	5.13.2	Change password
5.3	Tag name L2		
5.4	Backlight		
5.5	LCD Panel T unit		
5.6	User display 1		
5.7	User display 2		
5.8	User display 3		
5.9	User display 4		
5.10	User display 5		
5.11	User display 4 text		
5.12	User display 5 text		
5.13	Password protection		
5.14	Enable Auto Save		
5.15	En Auto Save React		
5.16	Panel HW + SW Version		

Within this submenu all LCD display related parameters can be configured. The figure shows the organization of the different parameter masks in the menu tree. The parameters are described in details in the chapter "11 Parameters and Data Structures on a Fieldbus->Parameter Organization->Display Parameters".

Maintenance and Service Parameters/Actions

Within this submenu all maintenance and service related parameters / actions can be configured. The figure below shows the organisation of the different parameter masks in the menu tree. Menu point 6.3.1 shows the list of errors and their occurrence in seconds since the start-up of the UMC. After a power cycle the history buffer is cleared. Use the up/down keys to scroll within the list. Menu point 6.3.2 shows present warnings. The "i" in the icon bar on the top level masks indicates the presence of warnings. Use the up/down keys to scroll within the list. Menu point 6.5 lists all changed parameters. This is useful if you want to verify the parameterization was carried out correctly or when calling a technical specialist who wants to know what has been configured. Menu point 6.4 allows to transfer the parameters and/or the application to the LCD panel and back.

6	Maintenance / service	6.1	Maintenance counters	6.4	Parameter transfer
6.1	Maintenance counters	6.1.1	Motor operation hours	6.4.1	Upload to LCD panel
6.2	Service tasks	6.1.2	Mot. stand still hrs	6.4.2	Download to UMC
6.3	Diagnosis	6.1.3	Number of starts		
6.4	Parameter transfer	6.1.4	Number of trips	6.4.1	Upload to LCD panel
6.5	Changed parameters	6.1.5	Remaining starts	6.4.1.1	Only parameter
6.6	UMC 100 SW version			6.4.1.2	Only application
		6.2	Service Tasks	6.4.1.3	Par and application
		6.2.1	Set operation hours		
		6.2.2	Reset oper. hours	6.4.2	Download to UMC
		6.2.3	Set stand still hrs		
		6.2.4	Reset stand still hrs	6.4.2.1	Only parameter
		6.2.5	Reset num. od starts	6.4.2.2	Only application
		6.2.6	Reset num. of trips	6.4.2.3	Par and application
		6.2.7	Reset parameters		
		6.2.8	Reset energy		
		6.3	Diagnosis		
		6.3.1	Error history		
		6.3.2	Present warnings		

Adjusting Parameters

Adjusting a numerical value

This type of dialog allows a numerical value to be specified within the given limits. The single digits must be defined from right to left. If the last digit was reached the right hot key changes from 'Next' to 'Save'. When pressing 'Save' the specified value is stored in the UMC. The mask can be exited at any time with the Cancel button (left hot key). In this case the changes are discarded.

The following example shows how to set the nominal motor current I_{e1} .

To change the digit use the up/down keys. As it is not possible to enter a value outside the given limits start editing the first digit by pressing the up button. If you reach 10, a 0 is displayed in the first digit and a 1 in the second digit. Press the left hot key now to go to the next digit.

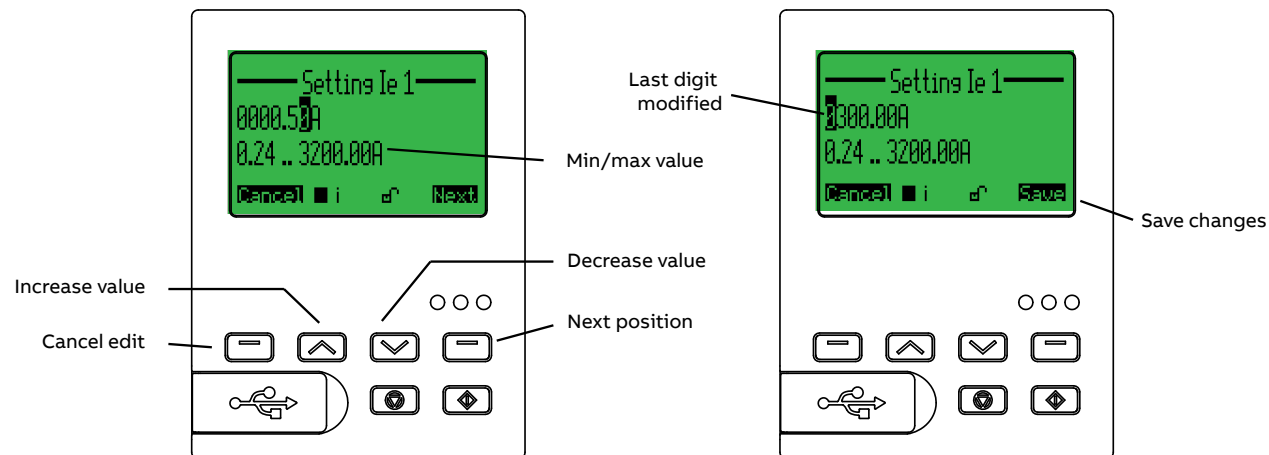

Selecting an option from a list

This type of dialog allows an item to be selected from a given list of options. With the up/down keys you can scroll through the list. The slider on the right shows the current position within the list. Pressing 'Select' chooses the currently marked item (inverted). Pressing 'Cancel' exits the dialog and discards the selection.

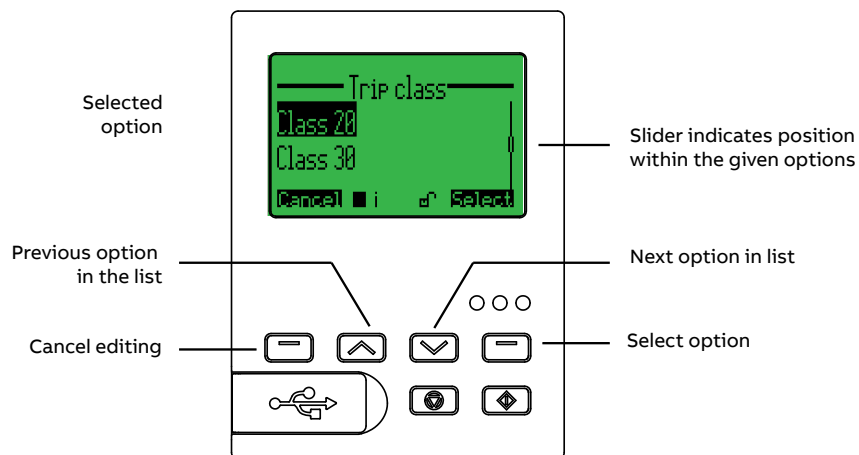

Specifying a text string

This type of dialog allows a character string to be specified e.g. an error message. With the up/down keys you can scroll through the alphabet and several special characters. Pressing 'Next' selects the next character to edit.

When the last character is reached you can save the text string by pressing 'Save' or discard the changes pressing 'Cancel'.

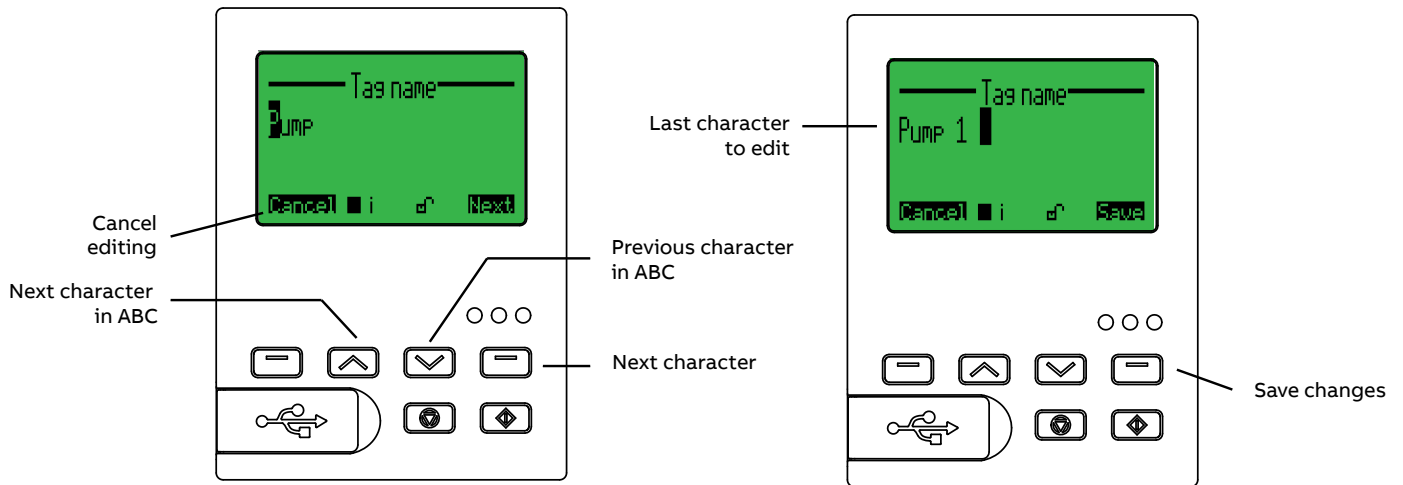

Use the LCD panel as parameter storage

For backup purposes or if several UMCs should be configured with a similar or same set of parameters the LCD panel can be used as storage. Up- and download are done by command. You can choose if you uploaded or download only the application or only the parameters or both.



Please note that the bus address will not be overwritten during download. This prevents communication problems due to the usage of the same bus addresses multiple times.

In case of a device replacement this means that the bus address must be set separately!

Use the LCD panel as automatic parameter backup storage

All settings can also be stored in the operator panel automatically. This is interesting in case of a UMC100.3 replacement. This new function requires that UMC and operator panel have at least the following revisions:

- UMC100.3 SW: 3.07 check via operator panel Maintenance/service -> UMC100 SW version
- Operator panel SW: 4.0

This function is not supported in the UMC100.3 ATEX and UMC100.3 ATEX with conformal coating!

The function stores

- All UMC100.3 configuration parameters
- Custom application
- Fieldbus address
- Address check
- I/O Data profile
- DeviceNet communication baudrate
- MODBUS communication data (baudrate, frame format, timeout)
- Retrofit
- Parameter for Ethernet/IP

It does not store

- Counter values (Number of trips, thermal trips, starts, emergency starts, operating hours, stand still hours, energy)
- All data related to the thermal memory (motor model)
- Historical data from function block NON_VOL_SR_FF

This function is by default deactivated (Auto Save = OFF).

Activation of Auto Save function

After configuration of the UMC100.3 the auto save function must be enabled. The activation is done by setting the parameter “Enable Auto Save = ON” in the LCD panel menu.

- All settings as mentioned above are now uploaded to the operator panel, the green LED on the UMC100.3 is flashing. This transfer takes a few minutes (~ 3 min.). After successful writing a disk symbol on the LCD-Panel indicates that this function is activated.
- From now on changed parameters are continuously stored into the LCD-Panel. Writing is indicated by the flashing disk symbol.
- At the next UMC100.3 startup a LCD-Panel with saved parameters is expected.

Deactivation of Auto Save function

With an activated parameter “Enable Auto Save = ON” the UMC100.3 always expects a valid LCD panel at startup. To deactivate this function:

- Set the parameter “Enable Auto Save = OFF” with the LCD-Panel
- The parameters stored in the LCD-Panel are deleted.
- During the next startup the UMC100.3 use the internal stored parameters.

Normal operation with active function and a parameter change is done

The disk symbol “Download to UMC” in the status line (first line) is blinking, until all parameters are stored into the LCD-Panel.

Replacing a UMC100.3 or behavior during power on, if auto save is enabled

UMC100.3: The green LED is blinking during the data transfer from LCD panel into UMC100.3.

LCD-Panel: In the main menu, in the Status line (first line) the text message “Download to UMC” is blinking. When the download to UMC100.3 is finished the normal text is displayed and a disk symbol is activated in the first line on the left side.

Replacing operator panel UMC100-PAN

UMC100.3: The green LED is blinking during the data transfer to the LCD-Panel.

LCD-Panel: In the main menu, in the Status line (first line) the text message “Upload to LCD panel” is blinking. When the upload to LCD-Panel is finished the normal text is displayed and a disk symbol is activated in the first line on the left site.

Parameter setting for warning “LCD panel missing”

A warning “LCD panel missing” can be enabled or disabled. The parameter is located in menu Display -> En Auto Save React. The default value is ON. If the function “Enable Auto Save” is activated and the LCD-Panel is disconnected later, a warning is generated “LCD panel missing”. This warning is also sent via fieldbus/network in the Diagnosis Byte 4 Bit 0.



Do not remove the LCD panel or power off the UMC100.3 in following cases

- The text message “Upload to LCD panel” is blinking
 - The text message “Download to UMC” is blinking
 - The disk symbol is blinking.
-

Starting and Stopping the Motor

If control via LCD panel was enabled, it is possible to start/stop the motor from the 'Control' menu which can be accessed from the top level menu when pressing the left hot key (Cntrl). Depending on the selected control function a list of possible start directions is displayed. Pressing the green start button starts the motor in the selected direction. Pressing the red stop button stops the motor. The motor status icons show you the present status of the motor.

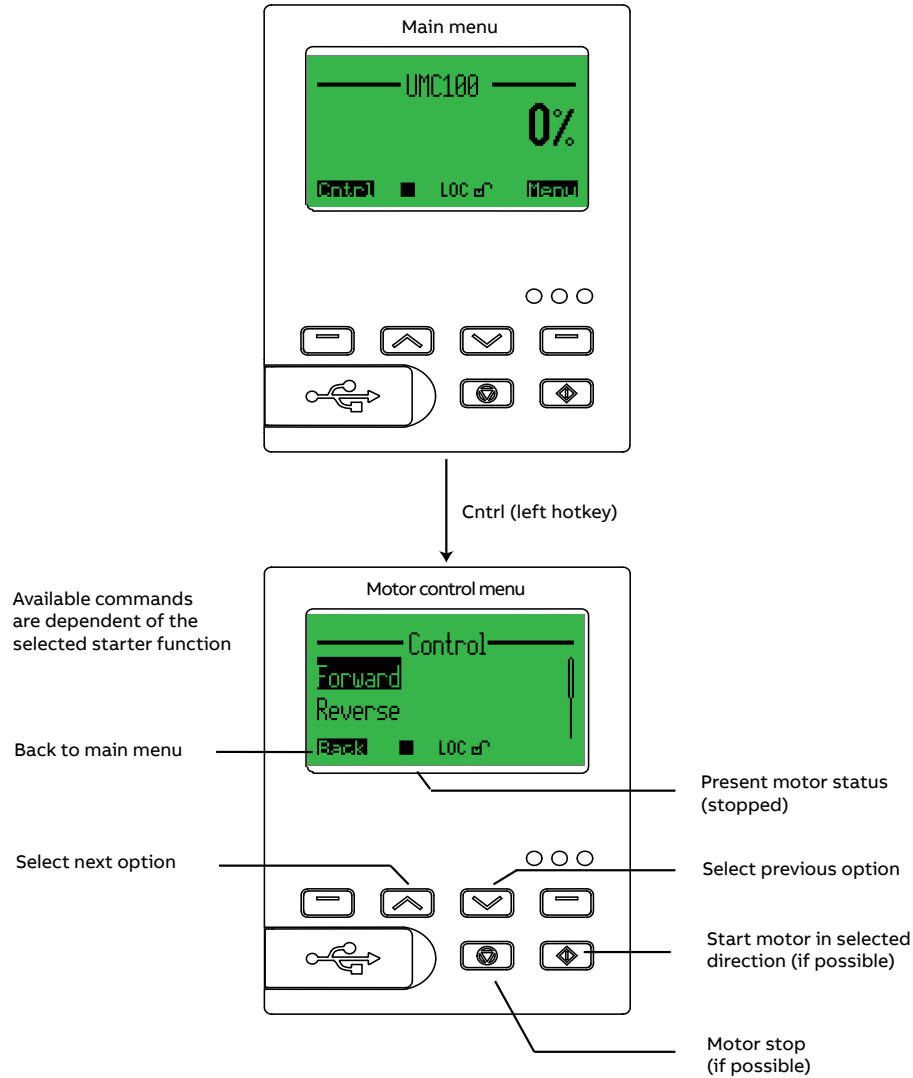

Acknowledge a Fault

If a fault is present the 'Cntl' menu is replaced with the menu to acknowledge faults (top level menu, left hot key). While a fault is present it is not possible to enter the Motor Control menu until the fault has been acknowledged. When entering the error menu the latest fault message is displayed. By pressing the right hot key 'Reset' you acknowledge the fault. If there is another fault pending it is displayed and can also be acknowledged until there is no further fault pending. Using the up/down keys it is possible to scroll through the list of present faults before acknowledging them. If the last fault was acknowledged the main menu is automatically entered. The menu can be exited at any time pressing the left hot key 'Back' without resetting any faults.

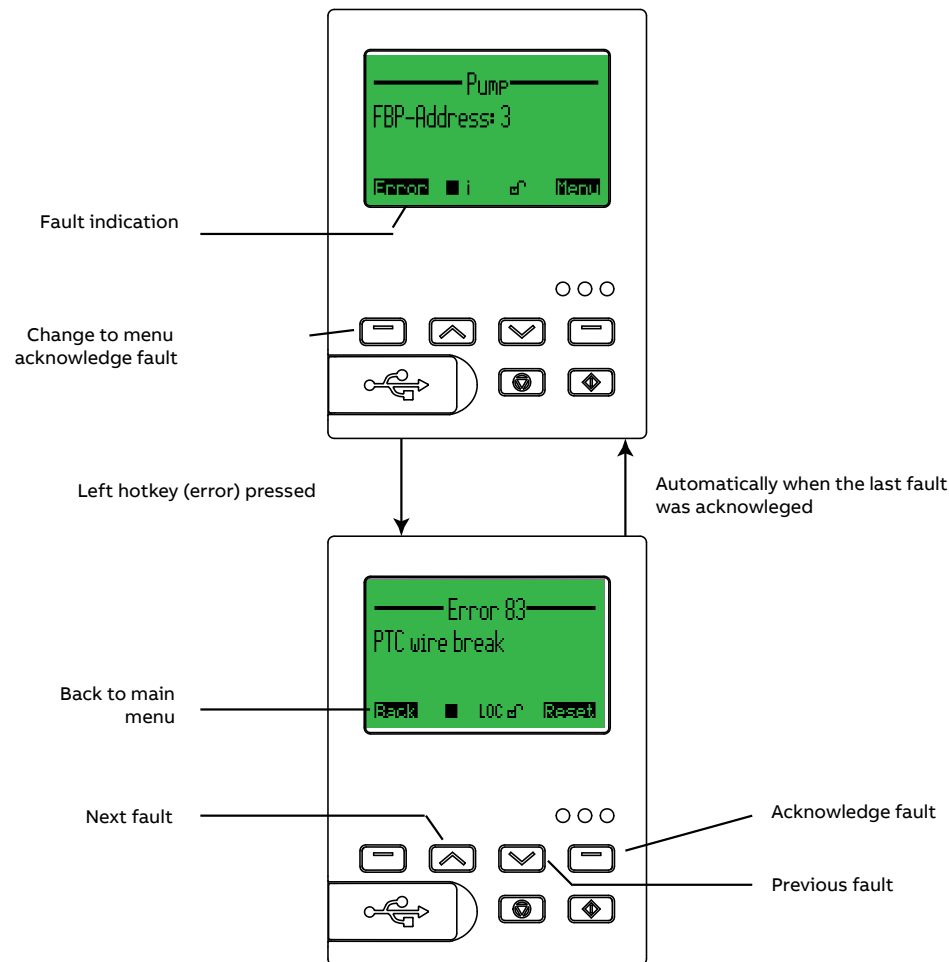

The table in chapter "9 Error Handling, Maintenance and Service->Error Handling of the UMC" lists all diagnosis and fault messages and potential root causes for the fault. It gives you a first indication of where to look for a fault and how to fix it. Use the error number shown in the heading (Error 83 in the example) for the look-up table.

9 Error handling, maintenance and service

Within this chapter you will find the following information

- Error handling of the UMC
- Detailed explanation of all error and diagnosis messages
- Functions related to maintenance and service

Error handling of the UMC

When the UMC detects a fault condition the fault becomes latched. Once a fault becomes latched, it remains latched - even if the underlying fault condition is eliminated - until acknowledged by a fault reset command.

Automatic Reset of Protection Faults

The setting of the "Fault autoreset" parameter determines how the UMC manages protection trips.

- Off (the default setting): A protection trip must be acknowledged by the user. This can be done via LCD panel, fieldbus or the multifunction inputs DI0-DI2 if configured.
- On: A protection trip is automatically acknowledged without intervention of either a human operator or the remote PLC if the trip condition has gone (e.g. cooling time over).

Fault History

The FIM UMC Edition software and the UMC100.3 control panel provide access to the fault history. The last 16 faults and their arrival time in seconds since power on are displayed. If the UMC is switched off the fault history is cleared.

UMC100.3 fault indication

The UMC offers the following possibilities for indicating a fault.

- Fault indication via digital outputs: The outputs DO2 and DO3 can be used to signal a summary fault. DO2 is a relay output that uses the same supply as DO0 and DO1. DO3 is a 24VDC output and can be used to drive a signal lamp as an example. The fault outputs can be configured with the parameter Fault Outputs.
- Fault indication via LEDs on the UMC: The red fault LED is switched on in the event of a fault and remains on until the fault is acknowledged.
- Fault messages on the LCD panel: See the table below.
- Signalling via fieldbus: In the event of a fault the "Fault Bit" in the cyclic communication telegram is set to logical-1. Furthermore a diagnosis telegram (if supported by the used fieldbus) is generated that describes the fault details.

Fault messages

The following table lists all diagnosis and fault messages and potential root causes for the fault. It gives you a first indication of where to look for a fault and how to fix it.

Indicator	Code	Source / Root Cause	Possible Cause / Suggested Action
Thermal overload trip	0	Load side	Trip because of thermal overload of the motor. Check process conditions Check if the cooling time is too short Check I_e and trip class settings Check current factor if configured Panel indicates the trip current in %
Phase loss	1	Supply side Load side Contactors	At least one phase current is below the phase loss threshold Check for blown fuse Check for loose contacts Check contact wear
Phase imbalance	2	Supply side Load side Contactors	The current in one phase is below the adjusted threshold. Check supply side Check for loose contacts Check contact wear
Locked Rotor	3	Load Side	The rotor is locked. Load too heavy for motor.

Indicator	Code	Source / Root Cause	Possible Cause / Suggested Action
Thermal model reached warning level	4	Load Side	Thermal model reached warning level. If overload condition remains a trip soon follows. Check motor load condition Check for mechanical problems
PTC overtemperature	5	Load side Environment	PTC element indicated that motor temperature is too high Check motor environment and load conditions
PTC wiring problem	6	Summary message. See detailed messages for more information.	See codes 83/84
Check-back error	7	Summary message. See detailed messages for more information.	See codes 80...82
Motor current below low current trip threshold	8	Process Load side Load side mechanics	Motor current is below user-defined threshold e.g. motor running idle, dry running pump, conveyer belt broken ... Check motor load and motor / process conditions. Wait until cooling time is over.
Motor current below low current warning threshold	9	Process Load side Load side mechanics	Motor current is below user-defined threshold e.g. motor running idle, dry running pump, conveyer belt broken ... Check motor load and motor / process conditions
Motor current above high current trip threshold	10	Load side	Motor current above threshold caused e.g. by jammed equipment Check process conditions (remove blocking cause). Wait until cooling time is over.
Motor current above high current warning threshold	11	Load side	Motor current above user-defined threshold. Check motor load and motor / process conditions.
Earth fault (external or internal sensor) above trip threshold	12	Load side electrical	Connection between one or more phases and ground Check wiring / motor (isolation problem)
Earthfault current above warning threshold	13	Load side electrical	See above
Selftest UMC HW	14	Electronics	Hardware fault detected, more details see under no. 128...140; On LCD panel: -> maintenance/service -> Diagnosis -> Error history Replace UMC
Actuator problem	15	Load side mechanics	Open/close time of actuator exceeded because of tight valve or other mechanical reasons. Check runtime parameter and limit and torque switch wiring
IO module missing	16	Electronics, Wiring	Communication cable not connected. Cable break or IO module hardware error.
Custom application error (e.g. download incomplete)	17	Configuration	An unrecoverable error was detected while processing the custom application (e.g. checksum error) The version of application editor and UMC are not compatible
IO module error	18	Electronics	A self-test error was detected in an IO module. Check the LEDs on the module Replace the module
Aux1: Error or warning triggered from auxiliary function block input 0	19	User-defined	The digital input of an IO module has created a trip/warning. Reason depends on what you have connected to the input.
Aux2: Error or warning triggered from auxiliary function block input 1	20	User-defined	Note: If the "AuxWarnFault" function block is used in a different way than in the predefined applications also other inputs than the DX1xx can be the fault source.
Aux3: Error or warning triggered from auxiliary function block input 2	21	User-defined	
Aux4: Error or warning triggered from auxiliary function block input 3	22	User-defined	
Aux5: Error or warning triggered from auxiliary function block input 4	23	User-defined	
Aux6: Error or warning triggered from auxiliary function block input 5	24	User-defined	
Multifunction input 0	25	User-defined	
Multifunction input 1	26	User-defined	
Multifunction input 2	27	User-defined	

Indicator	Code	Source / Root Cause	Possible Cause / Suggested Action
AM1 >/< level trip	28	Value on sensor >/< configured level	AI111 module; more details see under code no. 146..157
AM1 >/< level warn	29	Value on sensor >/< configured level	AI111 module; more details see under code no. 146..157
AM2 >/< level trip	30	Value on sensor >/< configured level	AI111 module; more details see under code no. 146..157
AM2 >/< level warn	31	Value on sensor >/< configured level	AI111 module; more details see under code no. 146..157
Warning LCD panel missing	32	If Auto Save is configured	Connect panel or deactivate Auto Save
Underload Power	34	Load side mechanics	The motor load is too low. Check the load e.g. if a pump is running dry or a conveyer load is broken.
Overload Power	35	Load side mechanics	The motor load is too high. Check if the load is blocked or tight.
Voltage Out of Spec	36	Load side	The supply voltage is too low or too high. Check the motor supply.
THD Warning	37	Supply side	The harmonics on the supply side are too high. Check your network.
Num Starts Overrun	43	Application	The motor was started too frequent.
Just One Start Left	44	Application	The motor was started too frequent.
Cooling time running	45	Process, Load side	Motor was tripped due to thermal overload. Restart is possible after cooling time is over
Parameter out of range	54	Electronics, Configuration	Someone tried to write a parameter which is outside the specifications Check the parameter number that is causing the problem and change the value. When writing parameters from within a PLC check your program.
Torque open in intermediate position	64	Actuator mechanics	Tight operation or wiring problem.
Torque close in intermediate position	65	Actuator mechanics	Tight operation or wiring problem.
Pos. open and closed at same time	66	Actuator mechanics	Wiring / position switch problem
End pos. open not left within specified time	67	Actuator mechanics	Wiring / position switch problem or wrong adjustment of position switch.
End pos. closed not left within specified time	68	Actuator mechanics	Wiring / position switch problem or wrong adjustment of position switch.
End position open without command	69	Actuator mechanics	Wiring / position switch problem.
End position closed without command	70	Actuator mechanics	Wiring / position switch problem.
Left pos. open without command	71	Actuator mechanics	Wiring / position switch problem.
Left pos. close without command	72	Actuator mechanics	Wiring / position switch problem.
Motor operation hour exceeded	74	Load side mechanical	Max. motor operation hours reached. Perform motor maintenance Reset counter
Wrong password	76	Electronics	
Line frequency out of range	77	Supply side	Check supply
Wrong phase sequence (reversal)	78	Supply side, Load side	Phase order is not L1/L2/L3.
CB relay 0	80	Wiring, Contactors	Expected feedback from a contactor is missing after checkback time was over. Check wiring of auxiliary contact to the correct UMC input. Check contactor Increase checkback time
CB StarDelta via Current	81	Contactors, Supply side, Load side	special case of code no 82
CB current	82	Contactors, Supply side, Load side	No motor current after motor was switched on and checkback time was over. Or motor current falls below 20% while motor is running. Check supply side Check that I_g was set correctly Check current factor if set Increase checkback time

Indicator	Code	Source / Root Cause	Possible Cause / Suggested Action
PTC wire break	83	Wiring	Check between UMC and motor
PTC short-circuit	84	Wiring	Check wiring between UMC and motor
DX111/DX122 module missing	85	Wiring, Electronics	The IO module does not respond during start-up of UMC. Check wiring between UMC and module
AI111 AM1 module missing	86	Wiring, Electronics	Check supply of module Check status LEDs of the module
AI111 AM2 module missing	87		
VX1xx module missing	88		
Overload analog output DX111/ DX122	92	Wiring, connected meter has a defect	Check wiring, short circuit at analog output
Wire break analog output DX111/DX122	93	Wiring	Check Wiring
Single phase mode not supported	94	Configuration	A voltage module not supporting single phase mode was configured for single phase mode. Use a voltage module with production index A5 or later.
U below trip/warn level	95, 96	Motor supply voltage is too low.	Check supply side: E.g. circuit breaker, fuses, wiring and the feeding.
U above trip/warn level	97, 98	Motor supply voltage is too high.	Check supply side: E.g. circuit breaker, fuses, wiring and the feeding.
AM1 CH1/2/3 Wire break AM2 CH1/2/3 Wire break	99,102,105 108,111,114	Wiring / 4-20 mA input	Check wire between AM1 and signal source
AM1 CH1/2/3 Sensor error AM2 CH1/2/3 Sensor error	100,103,106 109,112,115	Wiring / temperature sensor	Check wire between AM1 and temperature sensor
AM1 CH1/2/3 Out of range AM2 CH1/2/3 Out of range	101,104,107 110,113,127	Load side Configuration	Check that the configured sensor type is correct Check that the correct sensor type is connected Check that the delivered sensor signal in range.
P below trip/warn level	116, 117	Active power consumption of the motor is too low.	Either the motor is idle (not loaded) or the motor load is not connected because of a broken belt or a dry running pump etc. Check load side
PF below trip/warn level	120, 121	Active power consumption of the motor is too low	Either the motor is idle (not loaded) or the motor load is not connected because of a broken belt or a dry running pump etc. Check load side
Phase loss (voltage)	122	No voltage on one or more phases. Possible causes are a blown fuse or a wire break.	Check fuses Check wiring on supply side.
Phase imbalance (voltage)	123	There is a high imbalance on supply side e.g. because of unsymmetrical load of the three phases.	Check supply side especially the fuses and supply line.
Voltage out of range	124	The voltage is out of the specified voltage range	Check supply side. See code 95 – 98.
Wrong Phase Sequence (voltage)	125	The phases were wired in incorrect order.	Check wiring

Indicator	Code	Source / Root Cause	Possible Cause / Suggested Action
OK Stamp	128	OK Stamp not correct or missing	Hardware fault detected during selftest Replace UMC
Abgl. Checksum	129	Calibration checksum	
FRAM read/write	130	FRAM error	
Param D invers	131	Parameter storage error	
Thermal capacity	132	Thermal capacitor error	
VCC voltage	133	VCC voltage	
12VP voltage	134	12VP voltage	
12VN voltage	135	12VN voltage	
PTC channel	136	PTC_Channel	
Flash Checksum	137	Flash Checksum in microprocessor	
curr. meas. channel	139	current measure channel	
Selftest UMC_HW1	140	Summery fault (RAM, CPU,)	
Voltage DIP	144	Undervoltage / no voltage situation is too long	The DIP took longer than configured in parameter Voltage Dip Duration
Parameter up/download	145	A problem ocured during parameter exchange between the UMC and the LCD panel.	Check that the parameters / application stored in the LCD panel can be handled from the used UMC. Do not remove the panel while parameter exchange Do not remove power while parameter exchange.
AM1 CH1/2/3 HH/H AM2 CH1/2/3 HH/H	146,148,150 152,154,156	Value on sensor > configured HH/H level	Check process
AM1 CH1/2/3 LL/L AM2 CH1/2/3 LL/L	147,149,151 153,155,157	Value on sensor < configured L/LL level	Check process
AM1 max. temperature AM2 max. temperature	158 159	In temperature mode: Temperature of one of the sensors connected to AM1 is above configured maximal temperature	Check motor/process conditions
Motor stand still hours exceeded	160	Motor did not run for a long time	Start motor to check everyting is still fine
Error parameter inverters invers	161	Invalid parameter from auto save	Load correct parameters

Resetting parameters to factory defaults

It is possible to reset all parameters to the factory default settings. The fieldbus address is not affected from the reset command. Also the different maintenance counters are not affected but must be resetted manually at the UMC100-PAN.

The reset command can be activated via:

- UMC100-PAN

Resetting the password

The password can always be set or disabled using the FIM UMC Edition software or the UMC100-PAN.

Reading, setting and resetting maintenance counters

Preventive maintenance is the best way to ensure the long service life of any equipment.

The UMC provides several counters which help to better plan maintenance activities or to track down an existing problem.

- Number of motor starts can help to identify worn-out power contacts or to determine on contactor wear
- Number of protection trips
- Motor operation hours can help to assess the bearing status and its lubrication

The maintenance counters are available at the UMC100-PAN and in the FIM UMC Edition software.

I/O-Module status LEDs

Three LEDs show the module status. The following table explains the status messages.

Status			Explanation
Green LED	Yellow LED	Red LED	
On	On	On	Self-test during start-up
Flashing	Off	On	Communication with UMC was interrupted. Relay outputs switched off. Possible cause: Wiring between UMC and I/O module broken. Possible corrective measure: Check wiring and check that the module was activated in the UMC configuration.
Flashing	Off	Off	Waiting for communication with UMC. Module is ready. Possible cause: Wiring between UMC and I/O module broken. Possible corrective measure: Check wiring and check that the module was activated in the UMC configuration.
On	Off	Off	Cyclic data exchange with UMC. No diagnosis.
On	Flashing	Off	Cyclic data exchange with UMC. Diagnosis exists.
Irrelevant		Flashing	Hardware defect. Possible corrective measure: Replace module.
		Flashing	

Replacing a UMC100.3

The UMC and the internal current transformer are calibrated together in the ABB factory. Therefore the UMC must be completely replaced.

Set the parameters in the new UMC depending on your parameterisation concepts.



If you stored the parameters and/or your user defined application in the UMC100-PAN you can just download them from the panel back to the UMC100.3.

After mounting and connecting a new UMC, the communication starts up again.

Replacing an I/O Module

I/O modules are automatically parameterized by the UMC if the communication between UMC and I/O module has been established. No further user actions are required.

Requesting support

If you need support we kindly ask you to contact your local ABB representative using the template provided at the end of this manual.

Check the configuration

The menu option "Changed parameters" in the Service menu displays all parameters with changed settings (i.e., parameters with settings different from the default settings).

Using this function you can quickly check whether all parameters are set correctly



10 Safety and Commissioning Notes for Motors in Ex Areas

Introduction

This chapter provides safety and commissioning notes for motors that are installed in explosive atmospheres. The UMC100.3¹⁾ is a 1-channel device providing internal self tests which guarantees reliable motor protection on a high level. A suitable housing for the UMC100.3 is required when using the UMC in Ex areas.

The UMC100.3 must not be connected to frequency converters, softstarters or similar components in Ex applications.

The UMC100.3 is approved for device group II, category (2) zones "G" or "D". The UMC100.3 itself must not be exposed to the explosive atmosphere, unless used with a suitable housing. The protected motor may be exposed to an explosive atmosphere (i.e., explosive atmospheres caused by gases, vapors, mists or air, or by combustible dust).



The UMC100.3 was developed and designed according to the standards IEC 61508 and ISO 13849.

The increased risks in Ex areas require, amongst other things, careful observation of the following notes and standards:

- IEC 60079-7: Electrical apparatus for explosive atmospheres: Equipment protection by increased safety "e"
- IEC 60079-14: Electrical apparatus for explosive atmospheres: Electrical installations design, selection and erection
- IEC 60079-17: Electrical apparatus for explosive atmospheres: Electrical installations inspection and maintenance



UMC100.3 Marking:

 II (2) G [Ex e] [Ex d] [Ex px]  II (2) D [Ex t] [Ex p]

Explosive atmospheres acc. to IEC 60079	
[Ex e]	Equipment protection by increased safety "e"
[Ex d]	Equipment protection by flameproof enclosures "d"
[Ex px]	Equipment protection by pressurized enclosure "p"
Explosive atmospheres acc. to IEC 61241	
[Ex t]	Electrical apparatus for use in the presence of combustible dust – Protection by enclosures "tD"
[Ex p]	Electrical apparatus for use in presence of combustible dust – Type of protection "pD"



It is essential to observe the following notes! All work required for connection, commissioning and maintenance must be performed by qualified personnel. Improper behavior may cause serious injury to persons or material damages.

Safe state

For the reverse starter control function, the safe state is present if the relays DO0 and DO1 are de-energized (open). For all other motor operation modes (e. g. DOL, Star-Delta Start), the safe state is present if relay DO0 is de-energized (open).

¹⁾ Note: UMC100 is used as short form for the following devices:

UMC100.3 DC ATEX (24V DC supply)	1SAJ530000R0200
UMC100.3 UC ATEX (110-240 V AC/DC supply)	1SAJ530000R1200
UMC100.3 DC, conf. coating ATEX (24V DC supply)	1SAJ530000R0210
UMC100.3 UC, conf. coating ATEX (110-240 V AC/DC supply)	1SAJ530000R1210



Safety functions

The following functions of the UMC100.3 are safety-relevant:

- Thermal overload protection: The thermal overload protection function induces the de-energization of the relay(s) if the device detects a thermal overload situation (calculated using the thermal model) or a phase loss.
- Thermistor motor protection: This safety function brings the system to the safe state if the resistance measured at the PTC inputs (T1/T2) exceeds the limit specified in the corresponding standard.

This safety function only has to be activated if the motor provides a corresponding sensor.

Configuring the safety functions

A) Thermal overload protection

The following parameters have to be set for proper function of the thermal overload protection.

1. Nominal motor current I_{e1} , I_{e2} (parameter 29/30): Motors intended for use in Ex areas require the approval of the PTB or a comparable institution. For motors it is furthermore necessary to observe the ratio between the tripping current and the nominal current (I_a/I_e) and the heating period t_e . These information can be found in the certificate or on the motor type plate. The tripping time must be shorter than the heating period t_e , i.e., the tripping characteristic curve for the cold motor must run below the coordinate given by I_a/I_e and t_e . I_{e2} must be set only for the pole-changing starter control function.
2. Trip class (parameter 28): The tripping time must be shorter than the heating period t_e (see the example below).
3. Current factor (parameter 31) – for external current transformer: The transmission ratio of the used transformer must be set correctly.
4. Phase loss protection (parameter 42): The phase loss protection function is activated ex works. Deactivation of this function is only permitted for demonstration purposes. For single phase motors the parameter phase-loss is not relevant.
5. Resistive load must be set to "No" (parameter 26).
6. Set correct number of phases (parameter 47).

B) Thermistor motor protection

Example for trip class determination:

Type plate data of the motor:

Power = 7.5 kW; ratio $I_a/I_e = 7.4$; heating period $t_e = 11$ s

Tripping time for cold motor and symmetrical 3-phase load

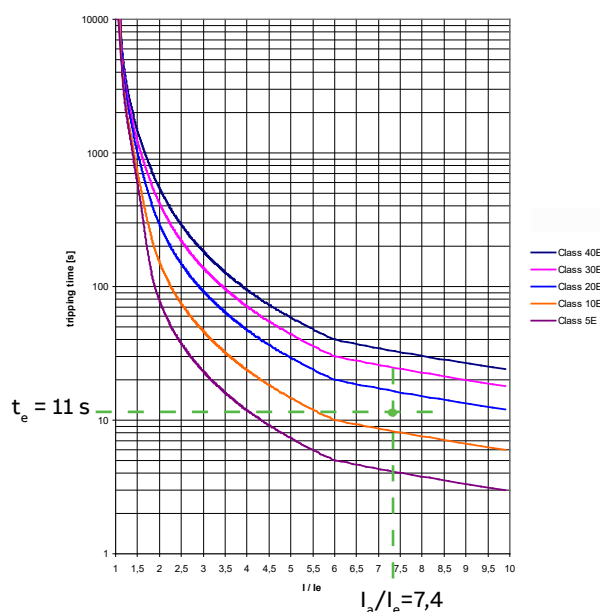

Due to the motor data given above, only the trip classes 10 and 5 are permitted for the selected motor (including a tolerance 10% for the UMC).

In order to select the correct motor starting solution for the application's purpose use the ABB coordination tables for motor protection: <http://applications.it.abb.com/SOC/Motor>



To activate the thermistor motor protection function it is necessary to change parameter 9 'PTC' to "Tripping". The input is then automatically monitored for short-circuit and wire break conditions. In case of a fault, a motor switch-off is initiated.

C) Signaling

Malfunction of the relay output or the main contactor is signaled as check back fault according to ISO 13849. Signaling may be performed via the fieldbus or an fault output (signaling relay or 24 V transistor output). The fault output is configured as sum fault output by default. To activate the fault output set parameter "Fault output (27)" according to the application's purpose.

D) Other parameters

1. Check back (parameter '22') is set to 'current' ex works and must not be changed.
2. Automatic reset of thermal overload faults. Parameter 14 'automatic reset' is set to 'off' ex works and must not be changed. This has no effects to the configurable error acknowledgement of external errors (on the multifunctional inputs or the DX1xx I/O module).
3. Test position: The multifunctional inputs (parameters 114/115/116) can be used to activate the test position. After commissioning, the test position must not be activated unintentionally during regular operation. This is usually avoided by the design of the switchgear (e.g. mechanical test position).
4. Emergency start: Parameter 15 'emergency start' is set to 'off' ex works and must not be changed.
5. According to IEC 60079-14 / 11.3, a phase imbalance detection function has to be configured for the protection of delta-connected motors during underload operation. Please refer to chapter "Configuring the Motor Protection Functions / Phase Imbalance Protection".

E) Checking the configuration

The correct parameter configuration can be checked as follows:

- On the LCD operating panel¹⁾
- Using the Device Type Manager (DTM): The parameters can be read from the device via DTM and then checked for correct configuration. This can be performed on site or via the bus.

F) Protecting the parameters against unintentional changes

Once the parameter configuration is finished, it is necessary to enable the parameter locking function in order to avoid unintentional changing of parameters. The state of the parameter locking function is indicated by the padlock symbol on the LCD operating panel.

Parameter locked: 

Parameter unlocked: 



LCD panel with locked parameters

Maintenance and repair

The devices do not require any service. Repair work may only be performed by the manufacturer.

¹⁾ Note: The menu option "Changed parameters" in the Service menu displays all parameters with changed settings (i.e., parameters with settings different from the default settings). Using this function you can quickly check whether all parameters are set correctly.



Tests

The device automatically performs periodic self tests. Therefore, no retesting has to be performed by the user if the motor is switched at least 1 time per year.

Otherwise, a test start of the motor must be performed to test the correct function of the relay.

Configuration via fieldbus



The same fieldbus configuration files can be used for the non-ATEX as well as the ATEX version.

11 Parameters and Data Structures on a Fieldbus

In the following chapter you find a detailed description of all UMC parameters, the format of the command monitoring and diagnosis telegrams. Furthermore the information is provided of how the UMC data is mapped to the different communication interfaces.



The tables below represent the data allocation as realised with the built-in standard applications. It may differ for customer-specific applications!

Monitoring Data

	Word	Byte	Bit 7	Bit 6	Bit 5	Bit 4	Bit 3	Bit 2	Bit 1	Bit 0	
Profile 1	0	0	Summary Warning	Summary Fault	Local Control ¹	Reverse Lockout Time ³	Overload warning	Run Forward ^{1,3} / Opening ^{2,3}	Off ³	Run Reverse ^{1,3} / Closing ^{2,3}	Profile 2
		1	UMC100 DI5	UMC100 DI4	UMC100 DI3	UMC100 DI2	UMC100 DI1	UMC100 DI0	Run Fast Forward ⁴	-	
	1	2, 3	Motor Current in % of I _e (0 % - 800 %)								
	2	4, 5	Analog Word (Thermal Load: 0 % - 100 %)								
	3	6, 7	Analog Word (Time to trip in seconds)								
	4	8, 9	Analog Word (Time to restart in seconds)								
	5	10,11	Analog Word (Active power in selected scale)								
	6	12	DX1xx DI7	DX1xx DI6	DX1xx DI5	DX1xx DI4	DX1xx DI3	DX1xx DI2	DX1xx DI1	DX1xx DI0	
		13	-	-	Run Time Exceeded ²	Out of Position ²	Torque Open ²	Torque Closed ²	End Pos Open ²	End Pos Closed ²	
	7	14	U Imbal. warn	U Imbal. trip	Undervoltage warn	Under-voltage trip	Underpower warn	Under-power trip	Over-power warn	Over-power trip	
		15	Earth fault warning	Earth fault trip	Cooling time running	-	THD warning	No start possible ⁵	1 start left ⁵	More than 1 start left ⁵	

Command Data

	Word	Byte	Bit 7	Bit 6	Bit 5	Bit 4	Bit 3	Bit 2	Bit 1	Bit 0	
Profile 1	0	0	-	Fault Reset	Auto Mode ³	Prepare Emergency Start	-	Run Forward ^{1,3} / Opening ^{2,3}	Off ³	Run Reverse ^{1,3} / Closing ^{2,3}	Profile 2
		1	UMC100 DO2	UMC100 DO1	UMC100 DO0	UMC100 24 V DC Out	-	-	Run Fast Forward ⁴	-	
	1	2	VI15x DO0	-	-	-	DX1xx DO3	DX1xx DO2	DX1xx DO1	DX1xx DO0	
		3	-	-	-	-	-	-	-	-	
		2	4, 5	Analog Word							
	3	6, 7	Analog Word								
	4	8,9	Analog Word								
	5	10,11	Analog Word								

¹ Not for Actuator 1 ... 4

² Only for Actuator 1 ... 4

³ Not for Overload Relay and Transparent

⁴ Only for Pole-Changing Starter

⁵ If start limit function is used

Diagnosis Data

Word	Byte	Bit 7	Bit 6	Bit 5	Bit 4	Bit 3	Bit 2	Bit1	Bit 0
0	0	Checkback missing	PTC wiring failure	PTC hot	Pre-waring thermal model	Locked rotor during start-up (stall)	Phase imbalance ¹	Phase loss ¹	Thermal overload trip
	1	Actuator problem ¹	UMC self-test error	Earth fault pre-warning	Eart fault trip (internal or externally triggered)	I above high current warning threshold	I above high current trip threshold	I below low current warning threshold	I below low current trip threshold
1	2	Trip/Warning from AuxFault function block input 5 ²⁾	Trip/Warning from AuxFault function block input 4 ²⁾	Trip/Warning from AuxFault function block input 3 ²⁾	Trip/Warning from AuxFault function block input 2 ²⁾	Trip/Warning from AuxFault function block input 1 ²⁾	HW fault on IO module	Custom application error	IO module missing
	3	Warning triggered from AM2	Trip triggered from AM2	Warning triggered from AM1	Trip triggered from AM1	Trip triggered from Multifunction input DI2	Trip triggered from Multifunction input DI1	Trip triggered from Multifunction input DI0	Trip / Warning from AuxFault function block input 6 ²⁾
2	4	-	-	THD Warning	Voltage out of spec ¹	Overload power	Underload power ¹	-	Warning LCD panel missing
	5	-	-	Cooling Time Running	Just one start left	Num Starts Overrun	-	-	-
3	6	Extended diagnosis is available ¹⁾ .	Parameter out of range	-	-	-	-	-	-
	7	Fault code. See chapter "9 Error Handling, Maintenance and Service-> Fault Messages" for a description of the code.							

¹⁾ There is more than one root cause that triggers this diagnosis. For details see diagnosis byte seven

²⁾ By default these diagnosis bits are triggered from the digital inputs of the DX111/DX122 IO module. If you have created an own custom application these diagnosis bits might be triggered for other reasons (see manual "Custom Application Editor" for more details).

For more information about integrating the UMC in a PROFIBUS network please refer to the PDP32.0 manual

For more information about integrating the UMC in a PROFINET IO network please refer to the PNQ22.0 manual

For more information about integrating the UMC in a Modbus network please refer to the MRP31.0 manual (Modbus communication interface)

For more information about integrating the UMC in a ModbusTCP network please refer to the MTQ22.0 manual

For more information about integrating the UMC in an EtherNet/IP network please refer to the EIU32.0 manual

Accessing Data on EtherNet/IP™

Similar to DeviceNet an Electronic Data Sheet (EDS) describes the features of an EtherNet/IP™ device and is used by software tools for device and network connection configuration. The latest EDS file can always be downloaded from the ABB website: www.abb.com

□ Products □ Low Voltage Products and Systems □ Automation, control and protection □ Motor controllers □ Universal Motor Controllers □ Ethernet Interfaces

The EIU32.0 allows concurrent communication with up to four EtherNet/IP™ clients (e.g. PLCs). Please note the following points:

- Only one of the connected devices can be the Exclusive Owner.
- All other connections have to be Listen-Only or Input-Only.
- In case several EIU32.0 are connected in a line, each of the devices can have a different Exclusive Owner.
- All connections that shall be used in parallel must be configured as "multicast connections".
- All connections that shall be used in parallel must be configured with the same RPI (Requested Packet Interval).

For more information about integrating the UMC in an EtherNet/IP™ network please refer to the EIU32.0 manual.

Accessing Data on PROFIBUS / PROFINET

On PROFIBUS/PROFINET the device parameters, monitoring data, diagnosis and command data is described in the GDS/GSDML file. Device parameters are transferred during bus start or UMC start from the bus master to the UMC. See also the chapters "6 Configuring the Communication Interfaces" and "3 Commissioning->Configuration from within the control system". For more information about integrating the UMC in a PROFIBUS network please refer to the PDP32.0 (PROFIBUS communication interface) technical manual. For more information about integrating the UMC in a PROFINET IO network please refer to the PNQ22.0 or PNU32.0 (PROFINET IO communication interface) technical manual.



For PROFIBUS bus masters with limited capability "I/O Data Profile 2" can be selected in the Profibus configuration. Additionally the UMC100.3 needs to be set in this mode by control panel or with the FIM configuration software.

Take care when changing a UMC100.3 (drawer or spare device) that this setting needs to be done manually!

Accessing Data on Modbus / ModbusTCP

On Modbus/ModbusTCP data is provided in so-called registers. A Modbus/ModbusTCP master can read and write data on these registers. For more information about integrating the UMC in a Modbus network please refer to the MRP31 (Modbus communication interface) technical manual. For more information about integrating the UMC in a ModbusTCP network please refer to the MTQ22 (ModbusTCP communication interface) technical manual.

Accessing Data on DeviceNet

On DeviceNet the device parameters, monitoring data and the command data size is described in the EDS file. Monitoring, command and diagnosis data is mapped to the data telegrams which are cyclically exchanged between the DeviceNet master and the UMC. For more information about device parameterisation in DeviceNet networks please refer to the DNP31 (DeviceNet communication interface) technical manual.



For DeviceNet bus masters with limited capability "I/O Data Profile 2" can be selected by using the EDS file "ABB_UMC100_R0101_Profile2.eds"

Additionally the UMC100.3 needs to be set in this mode by control panel or with the FIM configuration software.

Take care when changing a UMC100.3 (drawer or spare device) that this setting needs to be done!

Parameter Organisation

The UMC parameters are described in groups reflecting the major function blocks of the UMC. The figures in braces (e.g. 1.1) provide the link to the menu structure i.e. where it is displayed.

- Motor Management lists all parameters related to motor management i.e. starting and stopping the motor and the control function
- Protection lists all parameters related to the motor itself (e.g. nominal current) and the motor protection functions
- Communication lists parameters related to the fieldbus communication
- IO Module lists all parameters related to the optional IO expansion modules
- Display lists all parameters directly related to the LCD panel
- Function block lists all parameters related to a specific function block.

The column "Adjustable via" shows the possible options to adjust a parameter. "All" means the parameter can be set via UMC100-PAN, GSD Profibus, GSDML Profinet, EDS DeviceNet and EtherNet/IP and FIM software. Otherwise the available options are listed.

Motor Management Parameters

Parameter Number	Parameter	Description, Explanations	Options	Adjustable via
General motor management parameters				
20	Control function	Defines the type of starter function	Transparent (1), Overload relay (2), Direct starter (3), Reverse starter (4) Star-delta starter (5), Pole-changing starter (7), Actuator_1 (9), Actuator_2 (10), Actuator_3 (11), Actuator_4 (12) Softstarter (13)	All
21	Rev lock-out time	Interlocking time before a start command in the opposite direction is accepted	<u>1</u> -255 s	All
24	YD changeover mode	The UMC switches from star to delta either after a defined time or if the motor current has decreased to 90 % of I_{e1}	Time (0), Current (1)	All
25	YD starting time (Time Limit Actuator)	Time switching from star to delta. If the changeover mode is set to 'current' this time defines when the motor current must be below 90 % of I_e . Set this parameter to at least 1 s. Defines the maximum travel time from one end position to the opposite end position.	1 s to 360 s in steps of 0.1 s. Default: 60 s Unscaled: 10 ... 3600 Example: A value of 10 means 1 s	All
26	Resistive Load	Other than motor load connected	<u>No (0)</u> / Yes (1)	All
27	Fault output	Behaviour of DO2 or DO3 in the event of a trip or fault.	<u>Off (0)</u> , Flashing DO2 (1), On DO2 (2), Invert DO2 (3), Flashing DO3 (4), On DO3 (5), Invert DO3 (6)	All
47	Number of phases	Change from three phases to single phase load	<u>3 Phases (3)</u> 1 Phase (1)	All
22	Checkback	Selection of the checkback supervision method.	Contact DI0 (1), <u>Current (2)</u> , Simulation (3)	All
86	Inching DI start input (Jog)	Enables inching (i.e. jogging) of the start signal originating from a digital input.	<u>No (0)</u> , Yes (1)	All
19	Enable custom logic	Enable the execution of a customer defined application	<u>No (0)</u> , Yes (1)	All

Motor Management Parameters Continued

Parameter Number	Parameter	Description, Explanations	Options	Adjustable via
Local Control Mode 1				
90	Loc 1 start bus cyclic	Allow the motor to be started via cyclic bus command in local mode 1	<u>No (0),</u> <u>Yes (1)</u>	All
91	Loc 1 stop bus cyclic	Allow the motor to be stopped via cyclic bus command in local mode 1	<u>No (0),</u> <u>Yes (1)</u>	
94	Loc1 start LCD	Allow the motor to be started via LCD panel in local mode 1	<u>No (0),</u> <u>Yes (1)</u>	
95	Loc1 stop LCD	Allow the motor to be stopped via LCD panel in local mode 1	<u>No (0),</u> <u>Yes (1)</u>	
96	Loc1 start bus acyclic	Allow the motor to be started via acyclic bus command in local mode 1 (e.g. from FIM)	<u>No (0),</u> <u>Yes (1)</u>	
97	Loc1 stop bus acyclic	Allow the motor to be stopped via acyclic bus command in local mode 1 (e.g. from FIM)	<u>No (0),</u> <u>Yes (1)</u>	
92	Loc1 start DI	Allow the motor to be started via digital input in local mode 1	<u>No (0),</u> <u>Yes (1)</u>	
93	Loc1 stop DI	Allow the motor to be stopped via digital input in local mode 1	<u>No (0),</u> <u>Yes (1)</u>	
Local Control Mode 2				
106	Loc 2 start bus cyclic	Allow the motor to be started via cyclic bus command in local mode 2	<u>No (0),</u> <u>Yes (1)</u>	All
107	Loc 2 stop bus cyc	Allow the motor to be stopped via cyclic bus command in local mode 2	<u>No (0),</u> <u>Yes (1)</u>	
110	Loc2 start LCD	Allow the motor to be started via LCD panel in local mode 2	<u>No (0),</u> <u>Yes (1)</u>	
111	Loc2 stop LCD	Allow the motor to be stopped via LCD panel in local mode 2	<u>No (0),</u> <u>Yes (1)</u>	
112	Loc2 start bus acyclic	Allow the motor to be started via acyclic bus command in local mode 2 (e.g. from FIM)	<u>No (0),</u> <u>Yes (1)</u>	
113	Loc2 stop bus acyc	Allow the motor to be stopped via acyclic bus command in local mode 2 (e.g. from FIM)	<u>No (0),</u> <u>Yes (1)</u>	
108	Loc2 start DI	Allow the motor to be started via digital input in local mode 2	<u>No (0),</u> <u>Yes (1)</u>	
109	Loc2 stop DI	Allow the motor to be stopped via digital input in local mode 2	<u>No (0),</u> <u>Yes (1)</u>	
Auto Control Mode				
98	Auto start bus cyclic	Allow to start the motor via cyclic bus command in auto mode	<u>No (0),</u> <u>Yes (1)</u>	All
99	Auto stop bus cyclic	Allow to stop the motor via cyclic bus command in auto mode	<u>No (0),</u> <u>Yes (1)</u>	
102	Auto start LCD	Allow to start the motor via LCD panel in auto mode	<u>No (0),</u> <u>Yes (1)</u>	
103	Auto stop LCD	Allow to stop the motor via LCD panel in auto mode	<u>No (0),</u> <u>Yes (1)</u>	
104	Auto start Bus Acyclic	Allow to start the motor via acyclic bus command in auto mode (e.g. from FIM)	<u>No (0),</u> <u>Yes (1)</u>	
105	Auto stop Bus Acyclic	Allow to stop the motor via acyclic bus command in auto mode (e.g. from FIM)	<u>No (0),</u> <u>Yes (1)</u>	
100	Auto start DI	Allow to start the motor via digital input in auto mode	<u>No (0),</u> <u>Yes (1)</u>	
101	Auto stop DI	Allow to stop the motor via digital input in auto mode	<u>No (0),</u> <u>Yes (1)</u>	

Motor Management Parameters Continued

Parameter Number	Parameter	Description, Explanations	Options	Adjustable via
Invert control (ctrl) Inputs				
82	Inv DI start input	If inverted (Yes) the DI is normally closed. If not inverted (No) it is normally open.	<u>No (0)</u> , Yes (1)	All
83	Inv DI stop input	If inverted (Yes) the DI is normally closed. If not inverted (No) it is normally open.	No (0), <u>Yes (1)</u>	
Multifunction Inputs: The following parameters are all related to DI0-DI2 which are called multifunction inputs as their function can be adjusted in a wide range. (1.13)				
117, 118, 119	Multif. 0,1,2 delay	Delay until the function of DI0,1,2 is triggered	<u>0</u> ...25.5 in steps of 0.1 s Unscaled: 0...255 Example: A value of 5 means 500 ms	All
120, 121, 122	Multif. 0,1,2 auto reset	If DI0,1,2 is configured as external fault an auto reset can be enabled.	<u>No (0)</u> , Yes (1)	
135/136 137/138 139/140	Multif. 0,1,2 fault text Line 1, Line 2	If DI0,1,2 is configured as an external fault a text message can be defined which is shown on the LCD panel.	Line one and line two with 8 characters each. Default: „Fault Dlx“ where x=0,1,2	<u>FIM_LCD Panel</u> <u>UMC100-PAN</u>
114, 115, 116	Multifunction 0,1,2	Function of DI0/1/2. NC: Normally closed NO: Normally open ¹⁾ Motor running or stopped ²⁾ Always when the motor is running	<u>Off (0)</u> : Stop NC (1), Stop NO (2), Ext. Flt NC always ¹ (3), Ext. Flt NO always ¹ (4), Ext. Flt NC Motor on (5), Ext. Flt NO Motor on (6), Prep. emergency start NC (7), Prep. emergency start NO (8) Test position NC (9), Test position NO (10), Force local NC (11) Force local NO (12) Fault reset NC (13), Fault reset NO (14), Voltage DIP NC (15), Voltage DIP NO(16), CEM11 always ² (Warn) (17), CEM11 after startup (Warn) (18), CEM11 always ² (Fault) (19), CEM11 after startup (Fault) (20)	All
Extended				
23	Checkback time	The maximum delay between the output relay was closed until the checkback signal is present (signal at DIO present or motor current > 20 % depending on parameter Checkback)	0,1, 0,2, 0,3, 0,4, <u>0,5</u> ... 25.5 in steps of 0.1 s Unscaled: 0...255 Example: A value of 5 means 500 ms	All excluding GSD-PDQ22
15	Emergency Start	To allow start-ups even if the thermal overload protection would prevent them.	Off (0), On (1)	All
14	Fault auto reset	Automatically reset of selected protection faults (PTC, overload (EOL), imbalance and phase loss). Faults triggered from the UMC100 multifunction inputs and the IO module are not automatically reset. There are separate parameters.	Off (0), On (1)	All
81	Custom app parameter	Allows to specify a value which is available in the custom application.	0 ... 255	All
177	Param To PV 1	Selection of Processvalue 1 that is transferred via fieldbus	<u>1</u>	UMC100-PAN FIM
178	Param To PV 2	Selection of Processvalue 2 that is transferred via fieldbus	<u>2</u>	UMC100-PAN FIM
179	Param To PV 3	Selection of Processvalue 3 that is transferred via fieldbus	<u>3</u>	UMC100-PAN FIM
180	Param To PV 4	Selection of Processvalue 4 that is transferred via fieldbus	<u>4</u>	UMC100-PAN FIM
181	Param To PV 5	Selection of Processvalue 5 that is transferred via fieldbus	<u>5</u>	UMC100-PAN FIM



Motor Management Parameters Continued

Parameter Number	Parameter	Description, Explanations	Options	Adjustable via
Limit the Number of Starts				
148	Num Starts Allowed	Defines the number of permissible starts in the time window.	0 ... 32 Zero switches off the start limit function.	All excluding GSD-PDQ22
149	Num Starts Window	Defines a time window in which only a certain number of starts are allowed.	0 min ... 255 min (4.25 h) in steps of 1 min Default value: 0	All excluding GSD-PDQ22
150	Num Starts Pause	After the motor was stopped a new start is not possible before the pause time is over.. This paramter can be used independantly of the other parameters i.e. without limiting the number of starts in a time window.	0 min ... 255 min (4.25 h) in steps of 1min Default value: 0	All excluding GSD-PDQ22
155	Num Starts Overrun	Reaction if no start is left anymore but a start command was issued.	0: <u>Disabled</u> 1: Trip 2: Warning	All excluding GSD-PDQ22
221	Num Starts Prewarn	Reaction if only one start is left.	0: <u>Disabled</u> 1: Trip 2: Warning	All excluding GSD-PDQ22
Maintenance related parameters				
192	Motor operating hours level	After the defined number of weeks of motor operation a warning is triggered.	0 ... 255 (weeks) Default value is 0 that disables the supervision	All
193	Motor stand still level	After the defined number of weeks of continous motor stand-still time a warning is triggered.		

Protection Parameters

Parameter Number	Parameter Name	Description, Explanations	Options	Adjustable via
Protection Parameters				
29	Setting I_{e1}	Nominal current of motor for speed 1.	0.24...3200 A in steps of 0.01 A Default: 0.50 A Unscaled: 24...320000 Example: A value of 24 means 240 mA	All
30	Setting I_{e2}	Nominal current of motor for speed 2.	See above	All
28	Trip class	Class according to IEC/EN 60947-4-1	Class 5 (0), Class 10 (1), Class 20 (2), Class 30 (3), Class 40 (4)	All
31	Current factor	Current factor when using an external CT or when the motor wires are fed through the UMC CTs more than once.	2,3,4,5, 100 ... 64000 Examples: 3: motor wires are fed through 3 times 100: internal CT, no multiple feed-throughs 12500 means a factor of 125:1	All
9	PTC, Thermistor	Setting for the built-in PTC (Thermistor) protection. The reaction to hardware cannot be set separately.	Disabled (0), Trip(1), Warning(2)	All
48	Cooling mode	After a thermal overload trip which was triggered through the thermal motor model the cooling duration can be defined as fixed time or as a percentage of the thermal load level (0 %=cold, 100 % = trip)	Time (0), Restart Level (1)	All
49	Cooling time	The time a restart is inhibited following a thermal overload trip triggered by the thermal motor model	30 ... 64000 s Default value: 120 s	All
50	Restart level in %	Below this threshold a motor restart is accepted.	10...100 % Default value: 30 %	All excluding GSD-PDQ22
146	Thermal load warning level	If the thermal model reaches the warning level a warning is generated.	20 ... 100	All excluding GSD-PDQ22
Locked Rotor				
40	Locked rotor trip level	Current in percentage that should trigger a locked rotor fault during motor start-up. A value of 800% (160) switches off the function.	100 % ... 800 % in steps of 5 % 800 % disables the function Unscaled: 20 ... 160 Example: 100 means 500 %	All
41	Locked rotor trip delay	The time the motor current must exceed the adjusted threshold before a fault is triggered.	0, 0.1, 0.2, 0.3, 0.4, 0.5 ... 25.5 s in steps of 0.1 s Unscaled: 0...255 Example: 5 means 500 ms	All

Protection Parameters Continued

Parameter Number	Parameter Name	Description, Explanations	Options	Adjustable via
Phases				
42	Phase loss protection	Trips the motor depending of the trip class within 1.5 -12 seconds in case of a phase loss. This parameter must be set to On during regular operation.	Off (0), On (1)  Note: If the voltage module is present this parameter activates both voltage and current based phase loss detection.	All
43	Curr Imb Trip Level	Phase imbalance (current) trip threshold. Above this value a trip is generated. This function is activated together with the phase loss protection.	0...100 % Default value: 50	All excluding GSD-PDQ22
44	Curr Imb Warn Level	Phase imbalance (current) warning threshold. Above this value a warning is generated. This function is activated together with the phase loss protection.	0...100 %	All excluding GSD-PDQ22
45	Phase reversal	If enabled the three phases must be fed through the UMC CTs in the correct order (L1 left, L2 middle, L3 right).	L1L2L3 (0), L3L2L1 (1)  Note: If the voltage module is present this parameter must not be changed.	All excluding GSD-PDQ22
46	Check phase sequence	Enables supervision of phase sequence (L1/L2/L3)	Disabled (0), Trip (1), Warning (2)  Note: If the voltage module is present this parameter activates both voltage and current based phase sequence protection.	All excluding GSD-PDQ22
Over - and Undercurrent				
32	Low curr trip level	Value in % of I/I_e . Below this value a trip is generated. A value of 0% disables the trip.	0...100 % in steps of 5 % Default: 0 % 0% disables the function Unscaled: 0 ... 20 Example: 10 means 50 %	All
34	Low curr warn level	Value in % of I/I_e . Below this value a warning is generated. A value of 0% disables the warning.	0...100 % in steps of 5 % Default: 50 % 0% disables the function Unscaled: 0...20 Example: 10 means 50 %	All
33	Low curr trip delay	Delay time until a low current trip is triggered.	0...25.5 s in steps of 0.1 s Default: 0.5 s Unscaled: 0...255 Example: 20 means 2 s	All excluding GSD-PDQ22
35	Low curr warn delay	Delay time until a low current warning is triggered.	0...25.5 s in steps of 0.1 s Default: 0.5 s Unscaled: 0...255 Example: 20 means 2 s	All excluding GSD-PDQ22
36	High curr trip level	Value in % of I/I_e . Above this value a trip is generated. A value of 800% (160) disables the trip.	100...800 in steps of 5 % Default: 800 % 800 % disables the function Unscaled: 20...160 Example: 100 means 500 % (100 % is nominal current)	All
38	High curr warn level	Value in % of I/I_e . Above this value a warning is generated. A value of 800% (160) disables the warning	100...800 % in steps of 5 %. Default value is 150 %. 800 % disables the function Unscaled: 20...160 Example: 100 means 500 % (100 % is nominal current)	All
37	High curr trip delay	Delay time until a high current trip is triggered..	0...25.5 s in steps of 0.1 s Default: 0.5 s Unscaled: 0...255 Example: 20 means 2 s	All excluding GSD-PDQ22
39	High curr warn delay	Delay time until a high current warning is triggered.	0...25.5 s in steps of 0.1 s Default: 0.5 s Unscaled: 0...255 Example: 20 means 2 s	All excluding GSD-PDQ22

Protection Parameters Continued

Parameter Number	Parameter Name	Description, Explanations	Options	Adjustable via
Voltage Dip / Load Shedding				
142	Dip Enable	Enable / Disable function	Off (0), On (1), On + Rapid Cycle Lockout (2)	UMC100-PAN FIM
143	Voltage Dip Duration	Max. voltage dip duration time before a trip is signalled.	0.1...25.5 s in steps of 0.1 s Default: 0.5 s Unscaled: 1...255 Example: 5 means 0.5 s	All excluding GSD-PDQ22
144	Autorestart Window	If the voltage dip ends within this time window an autorestart is triggered (if enabled).	0.1 ... 1 s in steps of 0.1 s Unscaled: 1...10 Example: 5 means 0.5 s	UMC100-PAN FIM
145	Autorestart Delay	Delay until the motor is restarted	0 ... 255 s	UMC100-PAN FIM
147	Enable Autorestart	Enables the autorestart of the motor after end of the voltage dip	Off (0) On (1)	UMC100-PAN FIM
156	Dip Restart Level	Voltage level indicating the end of the low voltage situation	50 ... 115 % of U_n in steps of 1 % Default value: 90	
157	Dip Level	Voltage level indicating a low voltage situation and triggering the DIP logic.	50 ... 115 % of U_n in steps of 1 % Default value: 70	
Internal Ground Fault				
10	Earth Flt Trip Level	Above this ground fault current a ground fault trip is triggered. A value of 255 % disables the trip.	20 ... 80 in % of nominal current $I_{e1,2}$ (255 = off) Default value is 255 Example: $I_e = 100A$, Earth Flt Trip Level = 35 %. Then a earth fault current of 35 A triggers a trip.	All
11	Earth Flt Trip Delay	Delay time until a ground fault trip is triggered. Trip happens after the configured delay time plus a internal calculation time of about 600ms.	0...25.5 s in steps of 0.1 s Default: 0,5 s Unscaled: 0...255 Example: 20 means 2 s	All
12	Earth Flt Warn Level	Above this ground fault current a ground fault warning is triggered. A value of 255 % disables the warning.	20 ... 80 in % of nominal current $I_{e1,2}$ (255 = off) Default value is 255	All excluding GSD PDQ22
13	Earth Flt Warn Delay	Delay time until a ground fault warning is triggered. Warning happens after the configured delay time plus a internal calculation time of about 600 ms.	0...25.5 s in steps of 0.1 s Default: 0,5 s Unscaled: 0...255 Example: 20 means 2 s	All excluding GSD PDQ22
16	Earth Flt Detection	Mode of internal ground fault protection: Defines when the internal ground fault protection is active.	Always (0) After Startup (1)	All

Communication Parameters

Parameter Number	Parameter Name	Description, Explanations	Options	Adjustable via
17	Address check	Enable check if bus address stored in the UMC is the same as the one stored in the communication interface.	<u>Off (0)</u> , On (1)	All
18	Busfault reaction	UMC behaviour in the event of a bus fault.	<u>Motor Off (0)</u> , Retain (1), Start For (2), Start Rev (3)	All
-	Bus address	Fieldbus address. Depending on the communication interface used, the permitted address range is smaller than the one allowed here.	0,1,2,3 ... <u>255</u>	UMC100-PAN FIM
-	Parameter lock	Prevents any parameter changes if set to On.	<u>Unlocked (0)</u> , Locked (1)	UMC100-PAN
-	I/O Data profile	Set length of I/O data	<u>Profile 1</u> , Profile 2	UMC100-PAN
-	DeviceNet baudrate	Baudrate used if connected via DNP31 into a DeviceNet network	<u>Autobaud (0)</u> 125 kBaud (1) 250 kBaud (2) 500 kBaud (3)	UMC100-PAN FIM
-	MODBUS baudrate	Baud rate used if connected via MRP31 to a Modbus RTU network	1200 Baud (0) 2400 Baud (1) 4800 Baud (2) 9600 Baud (3) <u>19200 Baud (4)</u> 57600 Baud (5)	UMC100-PAN
-	MODBUS Frame	Frame type used if UMC is connected via MRP31 to a Modbus RTU network (number of data bits, parity, number of stop bits) Note: older versions of UMC100/UMC100.3 do not send this parameter, then an autodetection function is active	<u>8 Data, even, 1 Stop (1)</u> 8 Data, odd, 1 Stop (2) 8 Data, no, 2 Stop (3) 8 Data, no, 1 Stop (4)	UMC100-PAN
-	MODBUS bus timeout	The master has to send a telegram within the given time otherwise the UMC triggers the configured busfault reaction.	<u>0 (off)</u> ... 65535 ms	UMC100-PAN
-	IP setting mode	Mode how the IP address settings are made Note: in Basic Mode the IP address is created automatically as 192.168.0.xxx where (xxx = set by "Bus Address" Parameter)	<u>DHCP (0)</u> Basic (1) User defined (2)	UMC100-PAN
-	IP address, octet 1..4	IP address used if connected via Ethernet communication module to Ethernet network	0..255 Default: 192.168.0.1	UMC100-PAN
-	Subnet mask, octet 1..4	Subnet mask used if connected via Ethernet communication module to Ethernet network	0..255 Default: 255.255.255.0	UMC100-PAN
-	Gateway, octet 1..4	Gateway-IP address used if connected via Ethernet communication module to Ethernet network	0..255 Default: 0.0.0.0	UMC100-PAN
-	Enable Webserver	Enable/Disable webserver when connected to an Ethernet network	<u>Off (0)</u> On(1)	UMC100-PAN
-	Retrofit	To set UMC100.3 to UMC100.0 mode for backward compatibility	<u>Off (0)</u> UMC100-FBP (1)	UMC100-PAN

Communication Parameters Continued

Parameter Number	Parameter Name	Description, Explanations	Options	Adjustable via																																																																																				
177 - 181	Param To PV 1 ... 5	Defines which analog value is sent cyclically via analog monitoring word 0 ... 5	0 ... 255	All																																																																																				
		<table border="1"> <thead> <tr> <th>Value</th> <th>Number</th> </tr> </thead> <tbody> <tr><td>Current [%]</td><td>1</td></tr> <tr><td>Thermal load [%]</td><td>2</td></tr> <tr><td>TTT (Time to Trip) [s]</td><td>3</td></tr> <tr><td>TTC (Time to Cool) or TTR (Time to Restart) [s] depending on what triggers first</td><td>4</td></tr> <tr><td>Scaled Active Power (scaled with Power Scale Factor)</td><td>5</td></tr> <tr><td>Max Motor Current At Startup [%]</td><td>6</td></tr> <tr><td>Real Motor Startup Time [0,1s]</td><td>7</td></tr> <tr><td>Motor Current At Trip [%]</td><td>8</td></tr> <tr><td>Current unbalance [%]</td><td>9</td></tr> <tr><td>Frequency (Current or Voltage) [0,1Hz]</td><td>10</td></tr> <tr><td>PTC value [Ohm]</td><td>11</td></tr> <tr><td>Earth Fault [%]</td><td>12</td></tr> <tr><td>Number Of Starts</td><td>13</td></tr> <tr><td>Number Of Trips</td><td>14</td></tr> <tr><td>Number Of Thermal Trips</td><td>15</td></tr> <tr><td>Number Of Emergency Starts</td><td>16</td></tr> <tr><td>Number Of Starts Left (from FB Number of starts)</td><td>17</td></tr> <tr><td>Voltage U_{L1L2} [V] / U_{L1N} [V] in single phase mode</td><td>18</td></tr> <tr><td>Voltage U_{L2L3} [V]</td><td>19</td></tr> <tr><td>Voltage U_{L3L1} [V]</td><td>20</td></tr> <tr><td>Average Voltage [V]</td><td>21</td></tr> <tr><td>Power Factor [0,001%]</td><td>22</td></tr> <tr><td>Scaled Apparent Power (scaled with Power Scale Factor)</td><td>23</td></tr> <tr><td>Voltage Unbalance [0,1%]</td><td>24</td></tr> <tr><td>Voltage THD L1 [0,1%]</td><td>25</td></tr> <tr><td>Voltage THD L2 [0,1%]</td><td>26</td></tr> <tr><td>Voltage THD L3 [0,1%]</td><td>27</td></tr> <tr><td>AM1 Analog Value Channel 1 (K or raw value 0...xxxx)</td><td>28</td></tr> <tr><td>AM1 Analog Value Channel 2</td><td>29</td></tr> <tr><td>AM1 Analog Value Channel 3</td><td>30</td></tr> <tr><td>AM1 Max Temperature [K]</td><td>31</td></tr> <tr><td>AM2 Analog Value Channel 1 (K or raw value 0...xxxx)</td><td>32</td></tr> <tr><td>AM2 Analog Value Channel 2</td><td>33</td></tr> <tr><td>AM2 Analog Value Channel 3</td><td>34</td></tr> <tr><td>AM2 Max Temperature [K]</td><td>35</td></tr> <tr><td>Current L1 [%]</td><td>36</td></tr> <tr><td>Current L2 [%]</td><td>37</td></tr> <tr><td>Current L3 [%]</td><td>38</td></tr> <tr><td>Motor operation time [days]</td><td>39</td></tr> <tr><td>Motor standstill time [days]</td><td>40</td></tr> <tr><td>Reserved</td><td>45 - 255</td></tr> </tbody> </table>	Value	Number	Current [%]	1	Thermal load [%]	2	TTT (Time to Trip) [s]	3	TTC (Time to Cool) or TTR (Time to Restart) [s] depending on what triggers first	4	Scaled Active Power (scaled with Power Scale Factor)	5	Max Motor Current At Startup [%]	6	Real Motor Startup Time [0,1s]	7	Motor Current At Trip [%]	8	Current unbalance [%]	9	Frequency (Current or Voltage) [0,1Hz]	10	PTC value [Ohm]	11	Earth Fault [%]	12	Number Of Starts	13	Number Of Trips	14	Number Of Thermal Trips	15	Number Of Emergency Starts	16	Number Of Starts Left (from FB Number of starts)	17	Voltage U_{L1L2} [V] / U_{L1N} [V] in single phase mode	18	Voltage U_{L2L3} [V]	19	Voltage U_{L3L1} [V]	20	Average Voltage [V]	21	Power Factor [0,001%]	22	Scaled Apparent Power (scaled with Power Scale Factor)	23	Voltage Unbalance [0,1%]	24	Voltage THD L1 [0,1%]	25	Voltage THD L2 [0,1%]	26	Voltage THD L3 [0,1%]	27	AM1 Analog Value Channel 1 (K or raw value 0...xxxx)	28	AM1 Analog Value Channel 2	29	AM1 Analog Value Channel 3	30	AM1 Max Temperature [K]	31	AM2 Analog Value Channel 1 (K or raw value 0...xxxx)	32	AM2 Analog Value Channel 2	33	AM2 Analog Value Channel 3	34	AM2 Max Temperature [K]	35	Current L1 [%]	36	Current L2 [%]	37	Current L3 [%]	38	Motor operation time [days]	39	Motor standstill time [days]	40	Reserved	45 - 255	Numbers 1 ... 5 are transmitted in the analog monitoring words by default.	
Value	Number																																																																																							
Current [%]	1																																																																																							
Thermal load [%]	2																																																																																							
TTT (Time to Trip) [s]	3																																																																																							
TTC (Time to Cool) or TTR (Time to Restart) [s] depending on what triggers first	4																																																																																							
Scaled Active Power (scaled with Power Scale Factor)	5																																																																																							
Max Motor Current At Startup [%]	6																																																																																							
Real Motor Startup Time [0,1s]	7																																																																																							
Motor Current At Trip [%]	8																																																																																							
Current unbalance [%]	9																																																																																							
Frequency (Current or Voltage) [0,1Hz]	10																																																																																							
PTC value [Ohm]	11																																																																																							
Earth Fault [%]	12																																																																																							
Number Of Starts	13																																																																																							
Number Of Trips	14																																																																																							
Number Of Thermal Trips	15																																																																																							
Number Of Emergency Starts	16																																																																																							
Number Of Starts Left (from FB Number of starts)	17																																																																																							
Voltage U_{L1L2} [V] / U_{L1N} [V] in single phase mode	18																																																																																							
Voltage U_{L2L3} [V]	19																																																																																							
Voltage U_{L3L1} [V]	20																																																																																							
Average Voltage [V]	21																																																																																							
Power Factor [0,001%]	22																																																																																							
Scaled Apparent Power (scaled with Power Scale Factor)	23																																																																																							
Voltage Unbalance [0,1%]	24																																																																																							
Voltage THD L1 [0,1%]	25																																																																																							
Voltage THD L2 [0,1%]	26																																																																																							
Voltage THD L3 [0,1%]	27																																																																																							
AM1 Analog Value Channel 1 (K or raw value 0...xxxx)	28																																																																																							
AM1 Analog Value Channel 2	29																																																																																							
AM1 Analog Value Channel 3	30																																																																																							
AM1 Max Temperature [K]	31																																																																																							
AM2 Analog Value Channel 1 (K or raw value 0...xxxx)	32																																																																																							
AM2 Analog Value Channel 2	33																																																																																							
AM2 Analog Value Channel 3	34																																																																																							
AM2 Max Temperature [K]	35																																																																																							
Current L1 [%]	36																																																																																							
Current L2 [%]	37																																																																																							
Current L3 [%]	38																																																																																							
Motor operation time [days]	39																																																																																							
Motor standstill time [days]	40																																																																																							
Reserved	45 - 255																																																																																							

IO Module Parameters

DX111.0 / DX122.0 Parameters

Parameter Number	Parameter Name	Description, Explanations	Options	Adjustable via
8	Missing Module Reaction	Defines if the UMC creates a fault or a warning in case of a missing IO module.	<u>Error (0)</u> Warning (1)	All
1	DX1xx Enabled	Specify if the module is connected to UMC	<u>Off (0)</u> , On (1)	All
151	DX1xx DI delay	Input delay in ms assuming a line frequency of 50Hz	DX111: 3...200 ms Values are rounded up to the next multiple of 3. E.g.: 7,8,9 -> 9 ms delay In addition to the software delay a fix hardware delay of about 4 ms must be considered. DX122: 3...200 ms Values are rounded to the next multiple of 10. Values below 20 are rounded up to 20. E.g.: 3...20: 20 ms delay 81...90: 90 ms delay	All excluding GSD-PDQ22
152	DX1xx AO type	Hardware type of the analog output on the DX1xx module.	<u>0 - 20 mA (0)</u> , 4 - 20 mA (1), 0 - 10 mA (2), 0 - 10 V (3)	All excluding GSD-PDQ22
153	DX1xx AO error reaction	Reaction if the AO detects a short-circuit or wire break condition.	<u>Disabled (0)</u> , Trip (1), Warning (2)	All excluding GSD-PDQ22

VI150.0 / VI155.0 Parameters

Parameter Number	Parameter Name	Description, Explanations	Options	Adjustable via
4	VI15x Enabled	Specify if the module is connected to UMC	0: Off 1: On	All
158	Nominal Line Voltage	In three-phase mode: Line to Line Voltage e.g. 190 V, 400 V or 690 V In single-phase mode: Line to Neutral Voltage e.g. 110 V, 240 V, 400 V	U _n : 90...690 V in steps of 1 V (up to 400 V in single-phase mode) Default: 400 V	All excluding GSD-PDQ22
159	U Low Trip Level	Value in % of U/U _e . Below this value a trip is generated.	70 ... 100 % 70 disables the function	All excluding GSD-PDQ22
160	U Low Trip Delay	Delay time until a low voltage trip is triggered.	0...25.5 s in steps of 0.1 s Default: 3 s Unscaled: 0...255 Example: 20 means 2 s	All excluding GSD-PDQ22
161	U Low Warn Level	Value in % of U/U _e . Below this value a warning is generated.	70 ... 100 % 70 disables the function	All excluding GSD-PDQ22
162	U Low Warn Delay	Delay time until a low voltage warning is triggered.	0...25.5 s in steps of 0.1 s Default: 3 s Unscaled: 0...255 Example: 20 means 2 s	All excluding GSD-PDQ22
163	U High Trip Level	Value in % of U/U _e . Above this value a trip is generated.	100 ... <u>116%</u> of U _e in steps of 1 % 116 % disables the function	All excluding GSD-PDQ22
164	U High Trip Delay	Delay time until a high voltage trip is triggered.	0...25.5 s in steps of 0.1 s Default: 3 s Unscaled: 0...255 Example: 20 means 2 s	All excluding GSD-PDQ22
165	U High Warn Level	Value in % of U/U _e . Above this value a warning is generated.	100 ... <u>116%</u> of U _e in steps of 1 % 116 % disables the function	All excluding GSD-PDQ22
166	U High Warn Delay	Delay time until a high voltage warning is triggered.	0...25.5 s in steps of 0.1 s Default: 3 s Unscaled: 0...255 Example: 20 means 2 s	All excluding GSD-PDQ22
200	PwrFactor Trip Level	Power factor (cos phi). Below this value a trip is generated. 30 disables the function	<u>0.30</u> ... 1 in steps of 0.01 Unscaled: 30...100 Example: 75 means a PF of 0.75	All excluding GSD-PDQ22
201	PwrFactor Trip Delay	Delay time until a low power factor trip is triggered.	0...25.5 s in steps of 0.1 s Default: 3 s Unscaled: 0...255 Example: 20 means 2 s	All excluding GSD-PDQ22
202	PwrFactor Warn Level	Power factor (cos phi). Below this value a warning is generated. 30 disables the function	<u>0.30</u> ... 1 in steps of 0.01 Unscaled: 30...100 Example: 75 means a PF of 0.75	All excluding GSD-PDQ22
203	PwrFactor Warn Delay	Delay time until a low power factor warning is triggered	0...25.5 s in steps of 0.1 s Default: 3 s Unscaled: 0...255 Example: 20 means 2 s	All excluding GSD-PDQ22
204	U Imb. Trip Level	Voltage imbalance trip level 20 disables the function	0.2 ... <u>20%</u> in steps of 0.1 % Unscaled 2..200	All excluding GSD-PDQ22
205	U Imb. Trip Delay	Delay time until an imbalance trip is triggered	0...25.5 s in steps of 0.1 s Default: 1 s Unscaled: 0...255 Example: 20 means 2 s	All excluding GSD-PDQ22
206	U Imb. Warn Level	Voltage imbalance warning level 20 disables the function	0.2 ... <u>20%</u> in steps of 0.1 % Unscaled 2..200	All excluding GSD-PDQ22
207	U Imb. Warn Delay	Delay time until an imbalance warning is triggered	0...25.5 s in steps of 0.1 s Default: 1 s Unscaled: 0...255 Example: 20 means 2 s	All excluding GSD-PDQ22
208	P Low Trip Level	Below this value a trip is generated 20 disables the function	<u>20</u> ... 100 % in steps of 1 %	All excluding GSD-PDQ22
209	P Low Trip Delay	Delay time until an low power trip is triggered	0...255 s in steps of 1 s Default: 5 s	All excluding GSD-PDQ22
210	P Low Warn Level	Below this value a warning is generated. 20 disables the function	<u>20</u> ... 100 % in steps of 1 %	All excluding GSD-PDQ22
211	P Low Warn Delay	Delay time until an low power warning is triggered	0...255 s in steps of 1 s Default: 5 s	All excluding GSD-PDQ22

VI150.0 / VI155.0 Parameters Continued

Parameter Number	Parameter Name	Description, Explanations	Options	Adjustable via
212	P High Trip Level	Above this value a trip is generated 200 (1000 %) disables the function	100 ... 1000 % in steps of 5 % Unscaled: 20...200 Example: 20 means 100 %	All excluding GSD-PDQ22
213	P High Trip Delay	Delay time until an high power trip is triggered	0...255 s in steps of 1 s Default: 10 s	All excluding GSD-PDQ22
214	P High Warn Level	Above this value a warning is generated 200 (1000 %) disables the function	100 ... 1000 % in steps of 5 % Unscaled: 20...200 Example: 20 means 100 %	All excluding GSD-PDQ22
215	P High Warn Delay	Delay time until an high power warning is triggered	0...255 s in steps of 1 s Default: 10 s	All excluding GSD-PDQ22
216	Nominal Power Factor	Power factor value from the name plate or data sheet of the motor	0.01 ... 1 in steps of 0.01 Default: 1 Unscaled: 1...100 Example: 75 means a PF of 0.75	All excluding GSD-PDQ22
217	Power Scale Factor	Factor that can be used to scale the active and apparent power so that the resulting value fits in a WORD. This is needed for bus transfer.	0 = 1 1 = 10 2 = 100 3 = 1000 Example: U_e is 400 V, I_e is 200 A, Rated PF is 0.8. The nominal active power is then $400 \cdot 200 \cdot 1.73 \cdot 0.8 = 110720$. To transfer this value via fieldbus it must be scaled e.g. by 10. So the resulting value is $110720/10 = 11072$ which fits in a WORD.	All excluding GSD-PDQ22
219	THD Warning Level	Above this level of Total Harmonic Distortions a warning is triggered	3 ... 10 % in steps of 1 % 10 disables the function	All excluding GSD-PDQ22
222	THD Warning Delay	Delay time until an warning is triggered	0 ... 255 s in steps of 1 s Default is 5 s	All excluding GSD-PDQ22
220	Load Startup Delay	Delay time until load (e.g. pump) has started up and power supervision functions should become active.	0 ... 255 s in steps of 1 s	All excluding GSD-PDQ22

AI111.0 Parameters

Parameter Number	Parameter Name	Description, Explanations	Options	Adjustable via
2	AI111 AM1 Enabled	Specify if the module is connected to UMC	0: Off 1: On	All
3	AI111 AM2 Enabled	Specify if the module is connected to UMC	0: Off 1: On	All
154	AM1 Tmax Delay	Delay in temperature mode before a trip is triggered	0 ... 255 s in steps of 1 s	All
167	AM2 Tmax Delay	Delay in temperature mode before a trip is triggered	0 ... 255 s in steps of 1 s	All
188 / 189 / 190	AM1 CH1/2/3 Err Reac	Define error reaction for a specific analog input channel	Disabled (0), Trip (1), Warning (2)	All
182 / 183 / 184	AM1 Ch 1/2/3 Type	Define function of analog input channel	Disabled (0)	All
185 / 186 / 187	AM2 Ch 1/2/3 Type	Define function of analog input channel	PT100 -50 °C...+400 °C 2-wire (1) PT100 -50 °C...+400 °C 3-wire (2) PT100 -50 °C...+70 °C 2-wire (3) PT100 -50 °C...+70 °C 3-wire (4) PT1000 -50 °C...+400 °C 2-wire (5) PT1000 -50 °C...+400 °C 3-wire (6) KTY83 -50 °C...+175 °C (7) KTY84 -40 °C...+300 °C (8) NTC +80 °C...+160 °C (9) 0...10 V (10) 0...20 mA (11) 4...20 mA (12)	All
174 / 175	AM1 / AM2 Mode	Operation mode of analog module	Temperature (0) Universal (1)	All

UMC Display Parameters

Parameter Number	Parameter Name	Description, Explanations	Options	Adjustable via
123	Language	Language used on the LCD panel	<u>English (0)</u> German (1) French (2) Spanish (3) Italian (4) Portuguese (5) Russian (6) Polish (7) Finnish (8)	All
124	Tag name	String that is displayed on the LCD panel, part 1	String with 8 chars. Default: "UMC"	FIM UMC100-PAN
-	Tag name L2	String that is displayed on the LCD panel, part 2	String with 8 char.	FIM UMC100-PAN
125	Backlight	LCD backlight	Off (0), <u>On (1)</u>	All excluding GSD-PDQ22
128	User display 1	Process value shown on the top level menu.	<u>Thermal Load (0)</u> DX1xx DI (1) DX1xx DO (2) Operating Hours (3) Number of Trips(4) Number of Starts (5) Max. Startup Current (6) Real Startup Time (7)	All excluding GSD-PDQ22
129	User display 2	Process value shown on the top level menu.	see above (default is 'Max startup current')	
130	User display 3	Process value shown on the top level menu.	see above (default is 'Real startup time')	
131	User display 4	Process value shown on the top level menu.	Binary 1 (0) Binary 2 (1) Analog 1 (2) Analog 2 (3) <u>Time to Trip (4)</u> Time to Cool (5)	
132	User display 5	Process value shown on the top level menu.	see 'User display 4'. Default is 'Time to Cool'.	
133	User display 4 text	See custom application manual for more details.	Text string with 8 characters describing the displayed value (default text 'TTT')	FIM UMC100-PAN
134	User display 5 text	See custom application manual for more details.	Text string with 8 characters describing the displayed value (default text 'TTC')	
176	LCD Panel T Unit	Set displayed unit of temperature measured from AI111	<u>Celsius (0)</u> Fahrenheit (1)	All
Password Protection				
126	Password Protection	Enables the motor control / parameters to be password-protected	<u>Off (0)</u> On for Parameters (1) On for Param. + Motor Control (2)	All excluding GSD-PDQ22
-	Change Password	Password that permits parameters to be changed	<u>0000 ... 9999</u>	UMC100-PAN FIM

Function Block Related Parameters

Aux Input Block

In the standard built-in applications the inputs of this function block are connected to the digital inputs of the DX1xx module (see chapter "7 Using Expansion Modules").

Parameter Number	Parameter Name	Description, Explanation	Options	Adjustable via
51 - 56	Aux inp 1-6 ack mode	Definition of the fault reset behavior	<u>Manual Reset (0)</u> Auto Reset (1)	All
57 - 61	Aux Inp 1-6 reaction	Definition of the input function NC: Normally closed NO: Normally open	<u>Disabled (0)</u> Fault (NC) Motor in On/Off (1) Fault (NO) Motor in On/Off (2) Fault (NC) Motor in On (3) Fault (NO) Motor in On (4) Warning (NC) Motor in On/Off (5) Warning (NO) Motor in On/Off (6) Warning (NC) Motor in On (7) Warning (NO) Motor in On (8)	All
63/64 65/66 67/68 69/70 71/72 73/74	Aux Inp 1-6 message Line 1/Line 2	Message text line 1 and line 2	Free text with 8 characters for each line. Default: „Aux Dlx“ with x=1...6	FIM, UMC100-PAN
75 - 80	Aux Inp 1-6 delay	Input delay time in multiples of 100 ms	<u>0</u> ... 255 in multiples of 0.1 s Example: A value of 5 means 500 ms	All excluding GSD-PDQ22

All Parameters Sorted by parameter number

No	Name	Parameter Group
1	DX1xx Enabled	IO Module Parameters
2	AI1xx AM1 Enabled	IO Module Parameters
3	AI1xx AM2 Enabled	IO Module Parameters
4	VI15x Enabled	IO Module Parameters
8	Missing Module React.	IO Module Parameters
9	PTC, Thermistor	Protection
10	Earth Flt Trip Level	Protection
11	Earth Flt Trip Delay	Protection
12	Earth Flt Warn Level	Protection
13	Earth Flt Warn Delay	Protection
14	Fault Auto Reset	Motor Management
15	Emergency Start	Motor Management
16	Earth Flt Detection	Protection
17	Address Check	Communication
18	Busfault Reaction	Communication
19	Enable Custom Logic	Motor Management
20	Control Function	Motor Management
21	Rev Lock-Out Time	Motor Management
22	Checkback	Motor Management
23	Checkback Time	Motor Management
24	YD Change-Over Mode	Motor Management
25	YD Starting Time	Motor Management
26	Resistive Load	Motor Management
27	Fault Output	Motor Management
28	Trip Class	Protection
29	Setting Ie 1	Protection
30	Setting Ie 2	Protection
31	Current Factor	Protection
32	Low Curr Trip Level	Protection
33	Low Curr Trip Delay	Protection
34	Low Curr Warn Level	Protection
35	Low Curr Warn Delay	Protection
36	High Curr Trip Level	Protection
37	High Curr Trip Delay	Protection
38	High Curr Warn Level	Protection
39	High Curr Warn Delay	Protection
40	Locked Rotor Level	Protection
41	Locked Rotor Delay	Protection
42	Phase Loss Prot.	Protection
43	Current Imb Trip Level	Protection
44	Current Imb Warn Level	Protection
45	Phase Reversal	Protection
46	Check Phase Sequence	Protection
47	Number Of Phases	Motor Management
48	Cooling Mode	Protection
49	Cooling Time	Protection
50	Restart Level	Protection
51	Aux Inp 1 Ack Mode	Aux Input Block
52	Aux Inp 2 Ack Mode	Aux Input Block
53	Aux Inp 3 Ack Mode	Aux Input Block
54	Aux Inp 4 Ack Mode	Aux Input Block
55	Aux Inp 5 Ack Mode	Aux Input Block
56	Aux Inp 6 Ack Mode	Aux Input Block
57	Aux Inp 1 Reaction	Aux Input Block
58	Aux Inp 2 Reaction	Aux Input Block
59	Aux Inp 3 Reaction	Aux Input Block
60	Aux Inp 4 Reaction	Aux Input Block

No	Name	Parameter Group
61	Aux Inp 5 Reaction	Aux Input Block
62	Aux Inp 6 Reaction	Aux Input Block
63	Aux Inp 1 Message L1	Aux Input Block
64	Aux Inp 1 Message L2	Aux Input Block
65	Aux Inp 2 Message L1	Aux Input Block
66	Aux Inp 2 Message L2	Aux Input Block
67	Aux Inp 3 Message L1	Aux Input Block
68	Aux Inp 3 Message L2	Aux Input Block
69	Aux Inp 4 Message L1	Aux Input Block
70	Aux Inp 4 Message L2	Aux Input Block
71	Aux Inp 5 Message L1	Aux Input Block
72	Aux Inp 5 Message L2	Aux Input Block
73	Aux Inp 6 Message L1	Aux Input Block
74	Aux Inp 6 Message L2	Aux Input Block
75	Aux Inp 1 Delay	Aux Input Block
76	Aux Inp 2 Delay	Aux Input Block
77	Aux Inp 3 Delay	Aux Input Block
78	Aux Inp 4 Delay	Aux Input Block
79	Aux Inp 5 Delay	Aux Input Block
80	Aux Inp 6 Delay	Aux Input Block
81	Custom App Parameter	Motor Management
82	Invert DI Start Inp.	Motor Management
83	Invert DI Stop Inp.	Motor Management
86	Inching DI Start Inp	Motor Management
90	Loc 1 Start Bus Cyc	Motor Management
91	Loc 1 Stop Bus Cyc	Motor Management
92	Loc 1 Start DI	Motor Management
93	Loc 1 Stop DI	Motor Management
94	Loc 1 Start LCD	Motor Management
95	Loc 1 Stop LCD	Motor Management
96	Loc 1 Start Bus Acyc	Motor Management
97	Loc 1 Stop Bus Acyc	Motor Management
98	Auto Start Bus Cyc	Motor Management
99	Auto Stop Bus Cyc	Motor Management
100	Auto Start DI	Motor Management
101	Auto Stop DI	Motor Management
102	Auto Start LCD	Motor Management
103	Auto Stop LCD	Motor Management
104	Auto Start Bus Acyc	Motor Management
105	Auto Stop Bus Acyc	Motor Management
106	Loc 2 Start Bus Cyc	Motor Management
107	Loc 2 Stop Bus Cyc	Motor Management
108	Loc 2 Start DI	Motor Management
109	Loc 2 Stop DI	Motor Management
110	Loc 2 Start LCD	Motor Management
111	Loc 2 Stop LCD	Motor Management
112	Loc 2 Start Bus Acyc	Motor Management
113	Loc 2 Stop Bus Acyc	Motor Management
114	Multif In 0	Motor Management
115	Multif In 1	Motor Management
116	Multif In 2	Motor Management
117	Multif In 0 Delay	Motor Management
118	Multif In 1 Delay	Motor Management
119	Multif In 2 Delay	Motor Management
120	Multif In 0 Autoreset	Motor Management
121	Multif In 1 Autoreset	Motor Management
122	Multif In 2 Autoreset	Motor Management

No	Name	Parameter Group
123	Language	Display
124	Tagname	Display
125	Backlight	Display
126	Password Protection	Display
128	User Display 1	Display
129	User Display 2	Display
130	User Display 3	Display
131	User Display 4	Display
132	User Display 5	Display
133	User Display 4 Text	Display
134	User Display 5 Text	Display
135	Multif In 0 Message L1	Motor Management
136	Multif In 0 Message L2	Motor Management
137	Multif In 1 Message L1	Motor Management
138	Multif In 1 Message L2	Motor Management
139	Multif In 2 Message L1	Motor Management
140	Multif In 2 Message L2	Motor Management
142	Dip Enable	Protection
143	Dip Duration	Protection
144	Dip Autorestart Window	Protection
145	Dip Autorestart Delay	Protection
146	Thermal Load Warnlev	Protection
147	Dip Autorestart Enable	Protection
148	Num Starts Interval	Motor Management
149	Num Starts Window	Motor Management
150	Num Starts Pause	Motor Management
151	DX1xx DI Delay	IO Module Parameters
152	DX1xx AO Type	IO Module Parameters
153	DX1xx AO Err Reac	IO Module Parameters
154	AM1 Tmax Delay	IO Module Parameters
155	Num Starts Overrun	Motor Management
156	Dip Restart Level	Protection
157	Dip Level	Protection
158	Nominal Line Voltage	Protection
159	U Low Trip Level	Protection
160	U Low Trip Delay	Protection
161	U Low Warn Level	Protection
162	U Low Warn Delay	Protection
163	U High Trip Level	Protection
164	U High Trip Delay	Protection
165	U High Warn Level	Protection
166	U High Warn Delay	Protection
167	AM2 Tmax Delay	IO Module Parameters
168	AM2 CH2 Err Reac	IO Module Parameters
169	AM2 CH3 Err Reac	IO Module Parameters
170	AM1 Tmax Trip Level	IO Module Parameters
171	AM1 Tmax Warn Level	IO Module Parameters
172	AM2 Tmax Trip Level	IO Module Parameters
173	AM2 Tmax Warn Level	IO Module Parameters
174	AM1 Mode	IO Module Parameters
175	AM2 Mode	IO Module Parameters
176	LCD Panel T Unit	Display
177	Param To PV 1	Motor Management
178	Param To PV 2	Motor Management
179	Param To PV 3	Motor Management
180	Param To PV 4	Motor Management
181	Param To PV 5	Motor Management

No	Name	Parameter Group
182	AM1 CH1 Type	IO Module Parameters
183	AM1 CH2 Type	IO Module Parameters
184	AM1 CH3 Type	IO Module Parameters
185	AM2 CH1 Type	IO Module Parameters
186	AM2 CH2 Type	IO Module Parameters
187	AM2 CH3 Type	IO Module Parameters
188	AM1 CH1 Err Reac	IO Module Parameters
189	AM1 CH2 Err Reac	IO Module Parameters
190	AM1 CH3 Err Reac	IO Module Parameters
191	AM2 CH1 Err Reac	IO Module Parameters
192	Mot. op. hours level	Motor Management
193	Mot. stand still lev	Motor Management
200	PwrFactor Trip Level	Protection
201	PwrFactor Trip Delay	Protection
202	PwrFactor Warn Level	Protection
203	PwrFactor Warn Delay	Protection
204	U Imb. Trip Level	Protection
205	U Imb. Trip Delay	Protection
206	U Imb. Warn Level	Protection
207	U Imb. Warn Delay	Protection
208	P Low Trip Level	Protection
209	P Low Trip Delay	Protection
210	P Low Warn Level	Protection
211	P Low Warn Delay	Protection
212	P High Trip Level	Protection
213	P High Trip Delay	Protection
214	P High Warn Level	Protection
215	P High Warn Delay	Protection
216	Nominal Power Factor	Protection
217	Power Scale Factor	Protection
218	Pulse After x kWh	Protection
219	THD Warning Level	Protection
220	Load Startup Delay	Protection
221	Num Starts Prewarn	Protection
222	THD Warning Delay	Protection
1000	Parameter Lock	Communication
1001	Busaddress	Communication

12 Basic Circuit Diagrams

Direct Starter with IO modules and 110-240 V supply

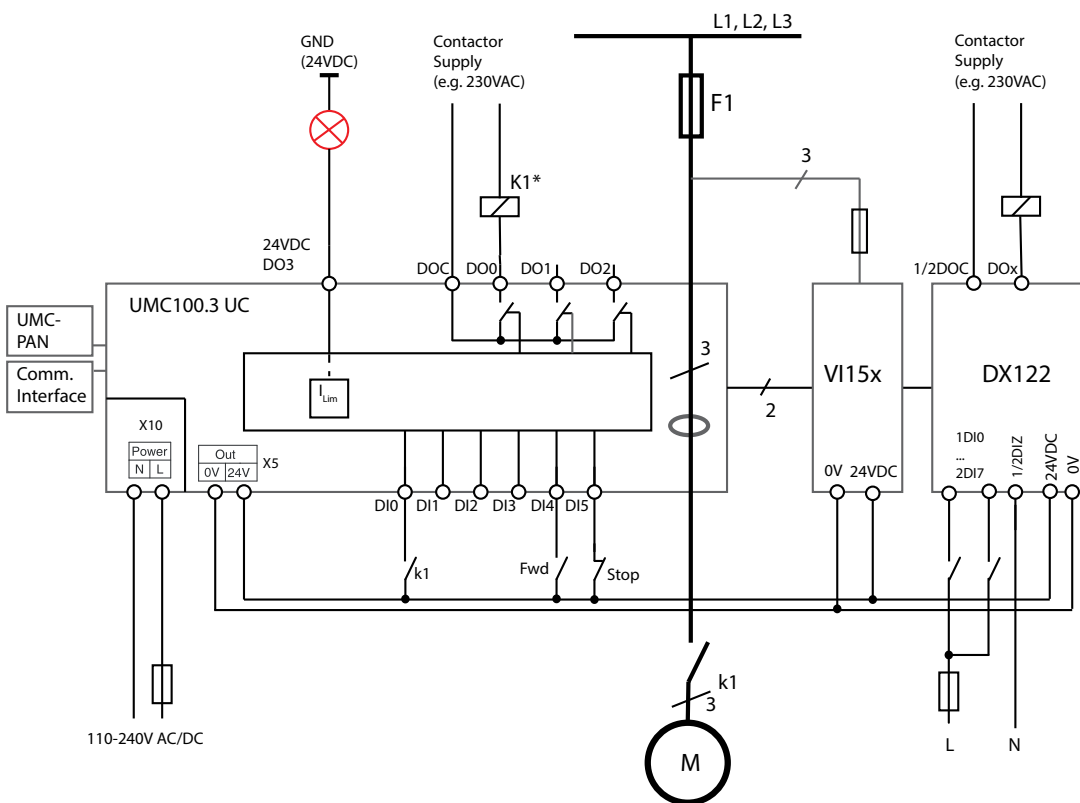
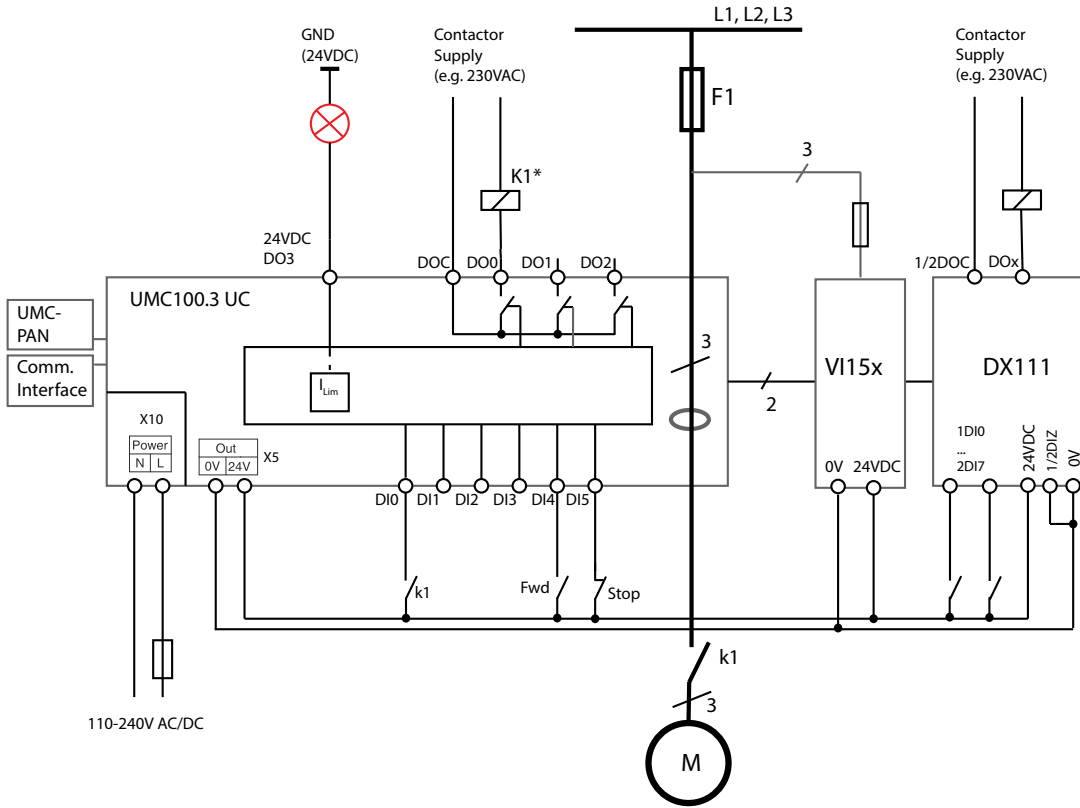

*) Use spark suppression for larger contactors

Emergency Stop Function for Direct Starter, Category 4

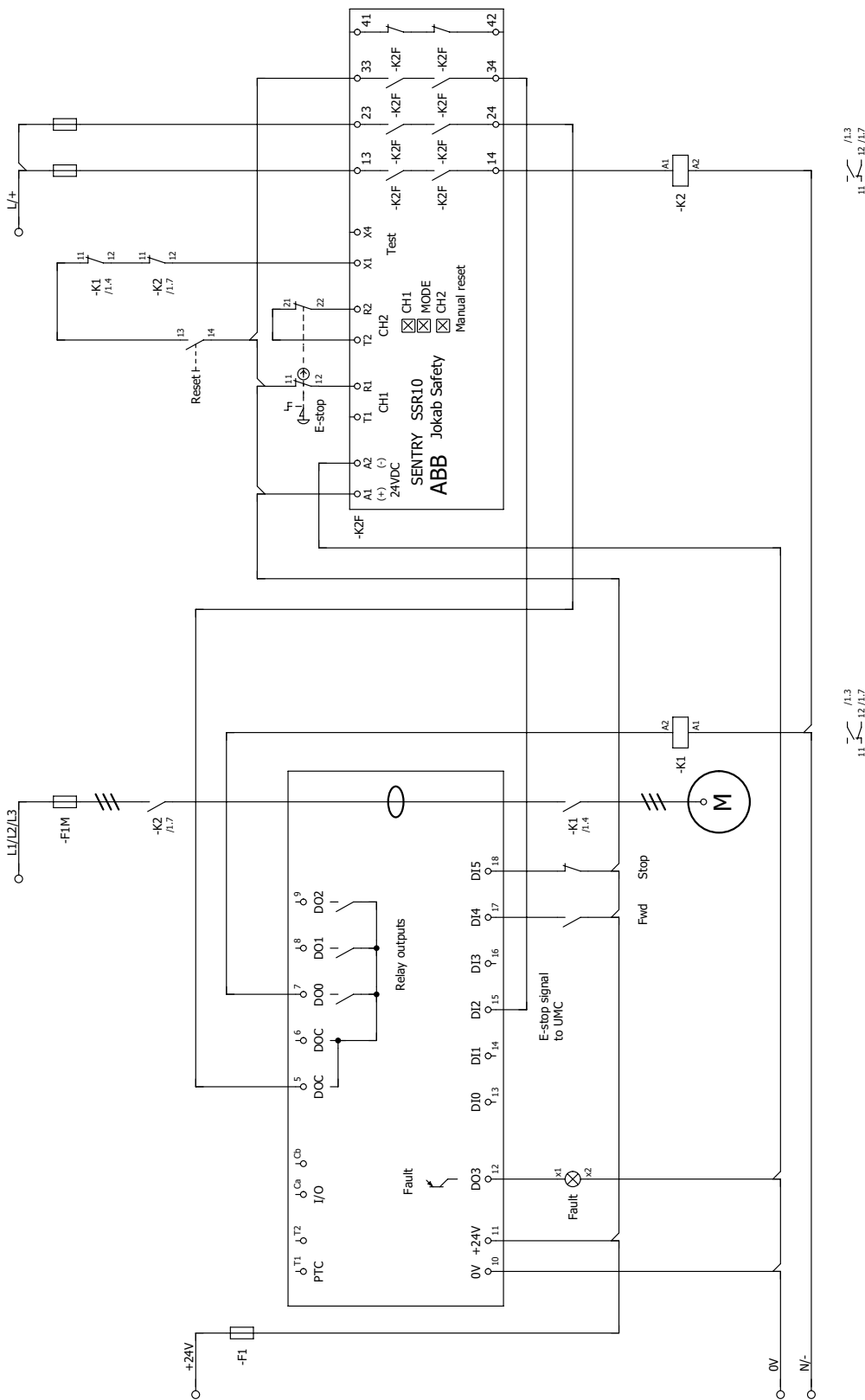

Circuit diagram showing safe-tripping with the help of an emergency stop relay. Carefully read the SSR10 manual on how to use this device. SIL level can depend on contactor type and its wear based on operations amount, please calculate accordingly.

*) Use spark suppression for larger contactors and also interface relays to maintain the service life of the UMC100 and RT9 internal relays.

Emergency Stop Function for Reversing Starter, Category 4

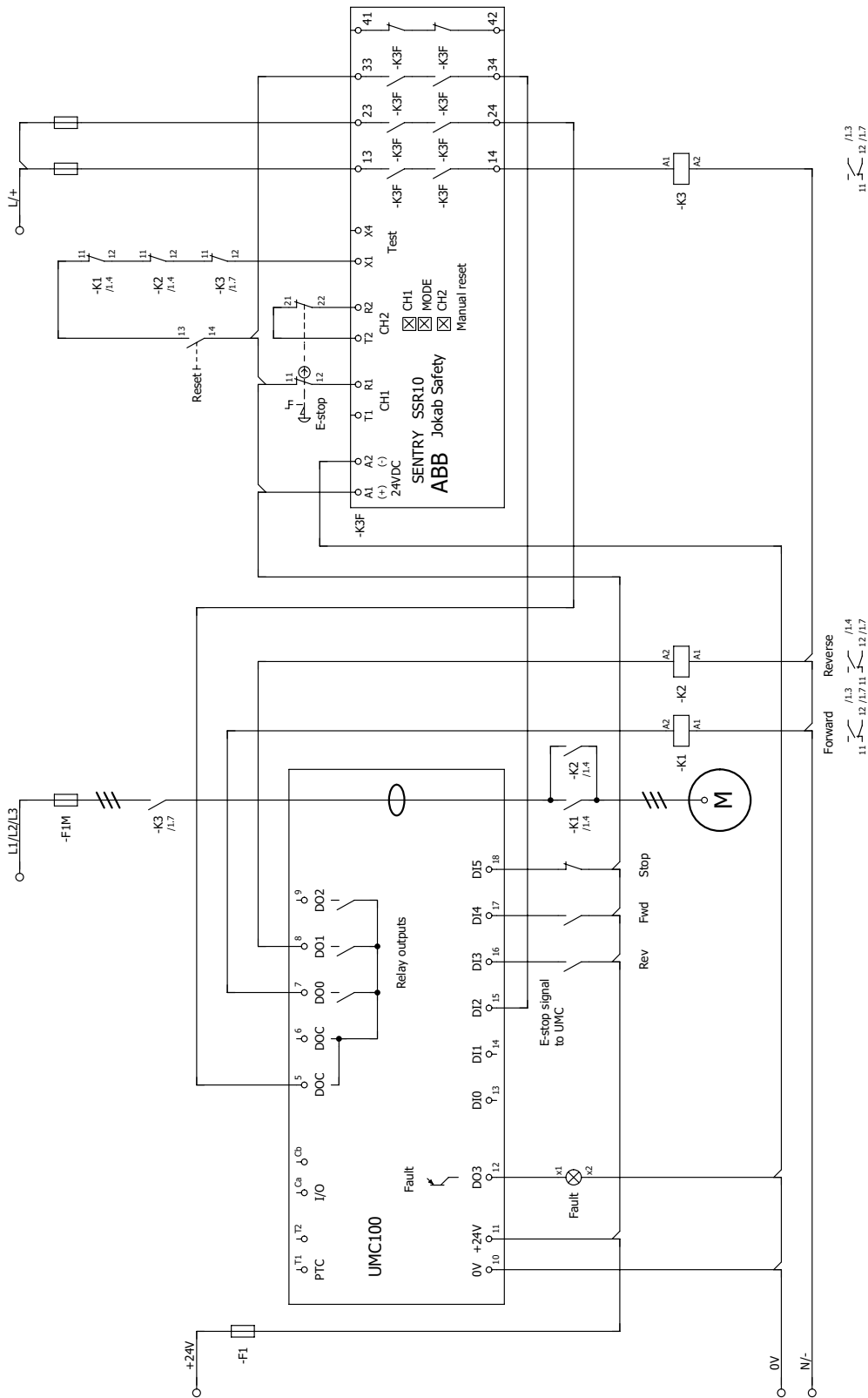

Circuit diagram showing safe-tripping with the help of an emergency stop relay. Carefully read the SSR10 manual on how to use this device. SIL level can depend on contactor type and its wear based on operations amount, please calculate accordingly.

*) Use spark suppression for larger contactors and also interface relays to maintain the service life of the UMC100 and RT9 internal relays.

13 Technical Data

UMC100.3

Main Power Lines

Voltage (three-phase systems)	Max. 1000 V AC Attention: For an U_{imp} of 8 kV and a voltage of 1000 V the device must be used according to Annex H IEC/EN 60947-1 in the range $600\text{ V} < U_e \leq 1000\text{ V}$. (IT Network) only for overvoltage category II. Otherwise overvoltage category III applies. Grounded networks: For voltages > 690 V isolated wires have to be used. Ungrounded networks: For voltages > 600 V isolated wires have to be used.			
Conductor holes in the current transformers	Max. diameter 11 mm incl. cable isolation			
Set current range for overload protection	UMC alone: 0.24-63 A (three phase) UMC alone: 0.24-20 A (single phase) UMC with provided current transformer: 60-850 A (see chapter 'Connecting External Current Transformers') For selecting the correct wire size see "Cross-section of wires"			
Overload protection for three-phase and single-phase motors	Acc. to IEC/EN 60947-4-1			
Trip classes, selectable by parameter	5E, 10E, 20E, 30E, 40E (acc. to IEC/EN 60947-4-1) Trip class 40E: Select the contactor and the protective elements with special care!			
Tolerance of tripping time (valid for currents higher than 3 times the current setting, operational temperature range and rated frequency)	UMC alone: +/- 10 % UMC with provided current transformer: +/- 14 %			
Tolerance of phase imbalance	+/- 10 %			
Tripping time for phase loss	Trip class: 5 approx. 1.5 s 10 approx. 3 s 20 approx. 6 s 30 approx. 9 s 40 approx. 12 s			
Accuracy of current measurement (range 50 to 200 % of I_e with $I_e > 0.5\text{ A}$)	UMC alone 3 % UMC with provided external current transformer: 4 %			
Load per phase	Approx. 30 mΩ			
Frequency range	50/60 Hz Protection of frequency converters is not allowed.			
Short-circuit protection	Provided by external short-circuit protection device, e. g. MO, MCB, MCCB or fuse. Refer also to ABB coordination tables available here: http://applications.it.abb.com/SOC/Page/Selection.aspx			
Cross-section of wires	Acc. to the rated motor current referring to IEC/EN 60947-1 and the specific installation condition in IEC/EN 60204 or VDE 298-4 resp.			
Vibration according IEC/EN 60068-2-6	0.7 g (without LCD Panel)			
Shock according IEC/EN 60068-2-27	15 g / 11 ms			
Performance under short-circuit conditions. Coordination type 2 Iq: Rated conditional short circuit current.	Iq	100 kA	50 kA	100 kA
	Up	690 V AC	1000 V AC	600 V AC
	Fuse	200 A gG	200 A gG	300A RK5

Tripping time for warm motor for three-phase and single-phase symmetrical loads

(Motor current $I_c/I_e = 100\%$ for long time before overloading)

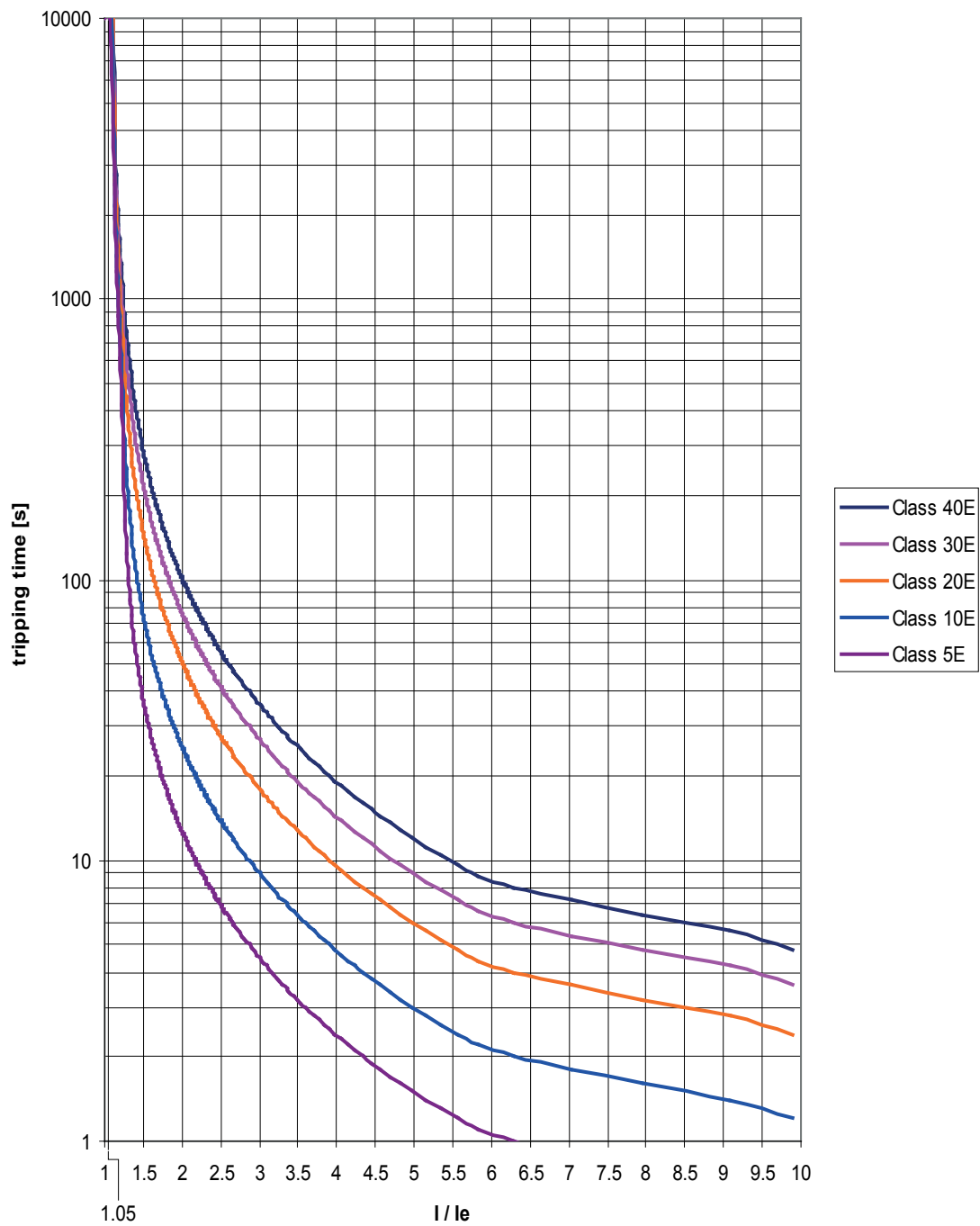

Tripping time for cold motor for three-phase and single-phase symmetrical loads

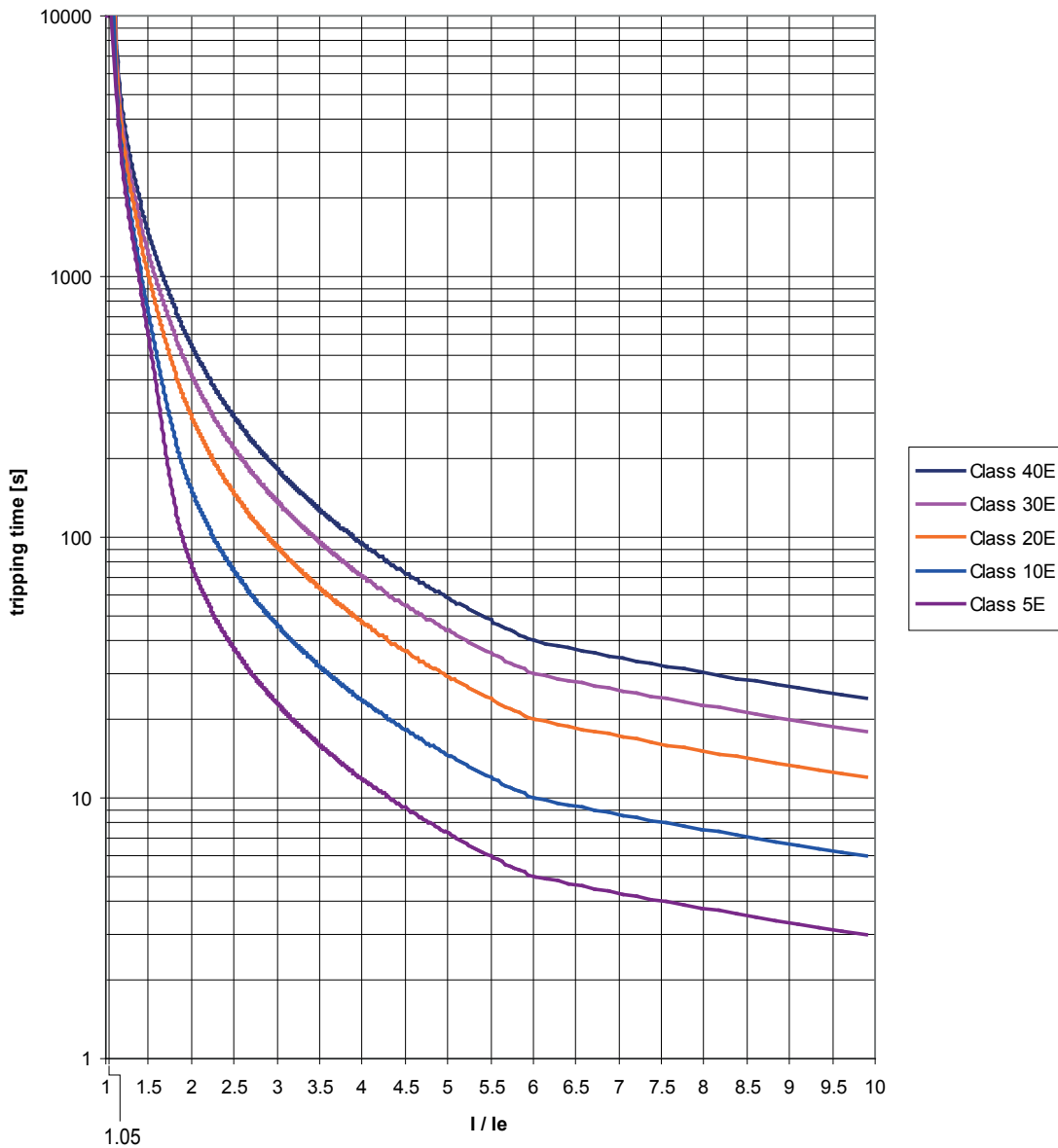

Controller Unit	1SAJ530000R0***	1SAJ530000R1***
Supply voltage	24 V DC (-20 % ... +30 %) (19.2 ... 31.2 V DC) incl. ripple.	110 V - 240 V AC/DC -15 % / +10 %
Buffering time	10 ms	10 ms
Reverse polarity protection	Yes	Not relevant
LEDs: green/red/yellow	Green: Ready for operation, Red: Error, Yellow: Motor is running	

Power consumption (typ.)	Conditions	1SAJ530000R0***		1SAJ530000R1***	
		P [W]	I [mA]	P [W]	S [VA]
UMC100.3	6 DI high; 3 relays on PTC=1.5 kΩ; In (motor)=4 A	3	120	3.5	8
Transistor output DO3	Depends on load max current 250 mA	0...6	0...250	0...1.5	0...2.5
PDP32.0	12Mbit; SUB-D with termination	1	41	1.2	2
MRP31.0	57.6 kbit	0.6	27	0.8	1.2
DNP31.0		0.5	20	1.0	1.5
EIU32.0	ETH1 and ETH2 active	2.2	90	3.2	5.8
UMC100-PAN	Backlight on	0.3	14	0.5	1
DX111.0	all DI high, all DO high	3	125	3.5	5.5
DX122.0	all DI high, all DO high	2	82	2.5	4.5
VI150.0	U _n = 400 V AC	0.6	27	0.8	1.2
VI155.0	U _n = 400 V AC	0.8	33	1.0	1.5
AI111.0		0.8	35	1.0	1.5

UMC100.3 UC 1SAJ530000R1*** provides 24 V DC supply for expansion modules, transistor output DO3 and communication interface.

Max current:

450 mA / T_u=50 °C

250 mA / T_u=60 °C

Following examples for the calculation of the load on '24 V out'

		Max load on '24 V Out'	
		T _u =50 °C	T _u =60 °C
UMC100.3 UC	6 DI high, 2 relays on PTC=1.5 kΩ; output DO3 off current in mA	450 mA	250 mA
PDP32.0	41		
DX111.0	125		
VI155.0	33		
AI111.0	35		
UMC100-PAN	14		
Transistor output DO3=off	0		
Sum	248	=> ok up to T _u =60 °C	
PDP32.0	41		
DX111.0	125		
VI155.0	33		
AI111.0	35		
UMC100-PAN	14		
Transistor output DO3=50 mA	50		
Sum	298	=> ok up to T _u =50 °C	

Digital Inputs	
Number of digital inputs	6 (DI0 ... DI5) Type 1 according to IEC/EN 61131-2
Supply for digital inputs	24 V DC
Isolation	No
Input signal bounce suppression	Typ. 2 ms
Signal 0 range including ripple	-31.2 ... +5 V
Signal 1 range including ripple	+15 ... +31.2 V
Input current per channel (24 V DC)	Typ. 6.0 mA
Input resistor to 0 V	3.9 k Ω
Cable length	unshielded max. 600 m shielded max. 1000 m

Relay Outputs	
Number of relay outputs	3 x monostable with one common root
Voltage range of contacts	12 - 250 V AC/DC
Lowest switched power for correct signals	1 W or 1 VA
Switching capacity per relay contact acc. to IEC/EN 60947-5-1 (electromagnetic load)	AC-15 240 V AC: max. 1.5 A AC-15 120 V AC: max. 3 A DC-13 250 V DC: max. 0.11 A DC-13 125 V DC: max. 0.22 A DC-13 24 V DC: max. 1 A
Short-circuit protection	6 A gG
U_{imp}	4 kV
Switching of inductive power	Inductive loads need additional measures for spark suppression. Diodes for DC voltage and varistors / RC elements for AC voltage are suitable. Some DC coil contactors contain rectifiers which suppress sparks perfectly.
Relay contact service life	Mechanical 500 000 switching cycles Electrical (250 V AC): 0.5 A: 100 000 cycles 1.5 A: 50 000 cycles
Internal clearance and creepage distances relay contacts to 24 V circuits	> 5.5 mm (safety insulation up to 250 V AC) (IEC/EN 60947-1, Pollution degree 2)
Pollution degree terminals	3
Supply power down/up, behaviour: Valid for all motor control functions, except transparent and overload relay.	Whenever the supply voltage of the UMC is switched off and on, starting of the motor needs a new RUN signal.

Digital Output	1SAJ530000R0***	1SAJ530000R1***
Max. output current	250 mA	250 mA
Short circuit protected	Yes	Yes
Output voltage if high	UMC100 supply voltage, nominal 24 V DC	nominal 24V DC
Isolation	No	Yes, to AC mains

Thermistor Motor Protection (PTC - binary) Type A	
Broken wire resistance	> 4.8 k Ω
Voltage at broken wires between terminals T1/T2	12 V DC (typ.)
Response resistance	3.4 - 3.8 k Ω
Reset resistance	1.5 - 1.65 k Ω
Short-circuit resistance	< 21 Ω
Current at short-circuit conditions	1.5 mA (typ.)
Response time	800 ms
Max. cold resistance of PTC sensor chain	< 1.5 k Ω
Line length	2.5 mm ² : 2 x 250 m 1.5 mm ² : 2 x 150 m 0.5 mm ² : 2 x 50 m
Isolation	No

Fieldbus Connection

Mounting	On UMC or remote with single mounting kit SMK3.0
Expansion connection	length max. 3 m
Suitable communication interfaces	Fieldbus: PROFIBUS: PDP32.0 or PDQ22 Modbus: MRP31.0 DeviceNet: DNR31 Ethernet: ModbusTCP PROFINET IO Older Fieldbus Plugs are compatible, but can not be plugged on the UMC100.3.

Environmental and mechanical data

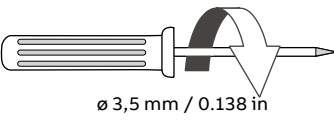
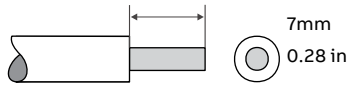
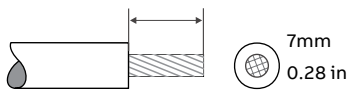
	1SAJ530000R0***	1SAJ530000R1***
Mounting	On DIN rail (EN 50022-35) or with 4 screws M4	
Mounting position	Any	
Dimensions (W x H x D)	70 x 105 x 106 mm	
Net weight	0.3 kg	0.35 kg
Wire size and tightening torque	 <p>0.5 Nm 4.5 in.lb</p> <p>Ø 3,5 mm / 0.138 in</p>  <p>7mm 0.28 in</p> <p>1x 0.2 ... 2.5 mm² 1x 28 ... 12 AWG</p>  <p>7mm 0.28 in</p> <p>1x 0.2-2.5 mm² 1x 28 ... 12 AWG</p>	
Tightening torque for screw mounting	0.8 Nm	
Degree of protection	UMC: IP20	
Temperature range storage	-25 ... +70 °C	
Temperature range operation	0 ... +60 °C with two output relays activated	0 ... +60 °C with two relay outputs activated and 24 V DC supply output loaded with 250 mA 0 ... +50 °C with two relay outputs activated and 24 V DC supply output loaded with 450 mA
Marks, approvals	CE, cULus, CCC, EAC ATEX for 1SAJ530000R0200, 1SAJ530000R1200, 1SAJ530000R0210, 1SAJ530000R1210	

Performance Data

Reaction time UMC100 DI to UMC100 relay output (incl. hardware delays)	typ. 10 ms (Transparent Control Function)
Reaction time UMC100 DI to DX111.0 relay output (incl. hardware delays)	typ. 10 ms (Transparent Control Function)
Reaction time from DX111.0 DI to UMC100 relay output (incl. hardware delays)	typ. 14 ms (Transparent Control Function)
Number of supported function blocks:	see 2CDC135034D0201

UMC100-PAN

Installation	Installation in a switchgear cabinet door or on a front panel.
Degree of protection	IP52 on front side, mounted with door mounting set IP54 on front side, mounted with door mounting kit plus protection cap
LEDs: Red/Yellow/Green	By default the LEDs have the same meaning as the ones on the UMC100. Red: Error Yellow: Motor is running Green: Ready for operation
Buttons	6 buttons with fixed meaning
Dimensions (WxHxD)	50 x 66 x 15 mm
Net weight	0.04 kg
Temperature range	Storage -25 ... +70 °C Operation 0 ... +55 °C
Tightening Torque for screw mounting	0.5 Nm
Micro-USB	Connector for device configuration with FIM UMC Edition software
Protection cap IP54 (accessory)	Silicone

DX111.0 and DX122.0

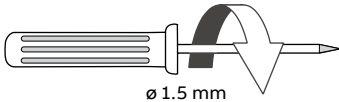
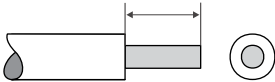
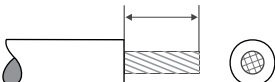
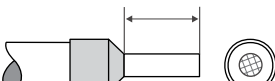
General	
Mounting	On DIN rail (EN 50022-35)
Mounting position	Any
Dimensions (W x H x D)	45 x 85,6 x 107 mm (excluding communication connector)
LEDs: Red/yellow/green	Red: Hardware error of module Yellow: Diagnosis available Green: Ready for operation
Supply voltage	24 V DC (+30 % ... -20 %) (19.2 ... 31.2 V DC) including ripple
Supply current	Max. 90 mA (at 19.2 ... 31.2 V DC)
Tightening torque for the communication terminals	<div style="display: flex; align-items: center; justify-content: space-between;"> <div style="text-align: center;">  <p>ø 1.5 mm</p> </div> <div style="text-align: right;">0.22 Nm</div> </div> <div style="display: flex; align-items: center; justify-content: space-between;"> <div style="text-align: center;">  <p>7 mm 0.28 in</p> </div> <div style="text-align: right;">1 x 0.14 ... 1.5 mm² 28 ... 16 AWG</div> </div> <div style="display: flex; align-items: center; justify-content: space-between;"> <div style="text-align: center;">  <p>7 mm 0.28 in</p> </div> <div style="text-align: right;">1 x 0.14 ... 1.5 mm² 28 ... 16 AWG</div> </div> <div style="display: flex; align-items: center; justify-content: space-between;"> <div style="text-align: center;">  <p>7 mm 0.28 in</p> </div> <div style="text-align: right;">1 x 0.25 ... 0.5 mm² 28 ... 16 AWG</div> </div>

General

Tightening torque for the input, output and supply terminals

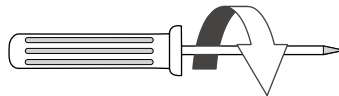

∅ 4,5 mm / 0.177 in / PH 1

0.6 ... 0.8 Nm
5.31 ... 7.08 in.lb

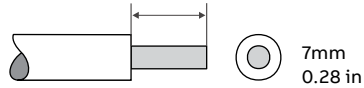

7mm
0.28 in

2 x 0.5 ... 4 mm²
2 x 20 ... 12 AWG

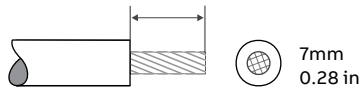

7mm
0.28 in

2 x 0.75 ... 2.5 mm²
2 x 18 ... 14 AWG

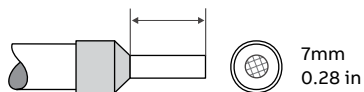

7mm
0.28 in

2 x 0.75 ... 2.5 mm²
2 x 18 ... 14 AWG

Net weight	0.24 kg
Degree of protection	IP20
Temperature range	storage -25 ... +70 °C operation 0 ... +55 °C (DX122.0) / +60 °C (DX111.0)
Marks, Approvals	CE, cULus, CCC, EAC

Relay Outputs

Number of relay outputs	4 1DO1, 1DO2 with root 1DOC 2DO3, 2DO4 with root 2DOC
Voltage range of contacts	12-250 V AC/DC
U_{imp}	4 kV
Short-circuit protection	6 A gG per root (1DOC, 2DOC)
Lowest switched power for correct signals	1 W or 1 VA
Switching of inductive power	Inductive loads need additional measures for spark suppression. Diodes for DC voltage and varistors / RC elements for AC voltage are suitable. Some DC coil contactors contain rectifiers which suppress sparks perfectly.
Switching capacity per relay contact acc. to IEC/EN 60947-5-1 (electromagnetic load)	AC-15 240 V AC: max. 1,5 A AC-15 120 V AC: max. 3 A DC-13 250 V DC: max. 0.11 A DC-13 125 V DC: max. 0.22 A DC-13 24 V DC: max. 1 A
Relay contact service life	Mechanical 500 000 switching cycles Electrical (250 V AC): 0.5 A: 100 000 cycles 1.5 A: 50 000 cycles
Internal clearance and creepage distances of relay contacts to 24 V circuits	> 5.5 mm (safety insulation up to 250 V AC) (IEC/EN 60947-1, Pollution degree 2) Pollution degree terminals: 3

Digital Inputs DX111.0

Number of digital inputs	8 externally supplied, isolated inputs Type 1 accord. to IEC/EN 61131-2 1DI0 ... 1DI4 with common root 1DIZ 2DI5 ... 2DI7 with common root 2DIZ
Supply for digital inputs	24 V DC
Isolation	Yes
Input signal bounce suppression	Typ. 6 ms
Signal 0 range including ripple	-31.2 ... +5 V
Signal 1 range including ripple	+15 ... +31.2 V
Input current per channel (24 V DC)	Typ. 6.0 mA
Input resistor to 0 V	3.9 k Ω
Cable length	unshielded max. 600 m shielded max. 1000 m

Digital Inputs DX122.0

Number of digital inputs	8 externally supplied, isolated inputs Type 2 accord. to IEC/EN 61131-2 1DI0 ... 1DI4 with common root 1DIZ 2DI5 ... 2DI7 with common root 2DIZ
Supply for digital inputs	110 V AC - 240 V AC
Isolation	Yes
Input signal bounce suppression	Typ. 20 ms
Signal 0 range including ripple	0 ... 40 V AC
Signal 1 range including ripple	74 ... 265 V AC
Frequency range	45 ... 65 Hz
Input current per channel (230 V AC)	Typ. 10 mA
Cable length	max. 200 m, cable capacity max. 300 nF/km

Analog Output

Type of connection	2-wire connection to display e.g. the motor current on an analog meter.
Configurable output range	0-10 mA, 0/4 mA - 20 mA, 0-10 V
Cable shielding	Recommended for up to 30 m and outside the switchgear cabinet; shielding mandatory for cables over 30 m
Max. output voltage	10 V
Accuracy	< 5 %
Max. output load	500 Ω (if configured as current output)
Min. output load	1 k Ω (if configured as voltage output)
Resolution	8 bit
Short-circuit-proof	Yes
Open-wire detection	Yes, if configured as 0/4-20 mA output
Short-circuit detection	Yes, if configured as 0-10 V output
Isolation	No

VI150.0 and VI155.0

General	
Mounting	On DIN rail (EN 50022-35)
Mounting position	Any  A distance of 10 mm left and right to the L1 and L3 terminals might be necessary depending on the other devices mounted beside for voltages > 230 V / 400 V respectively
Dimensions (W x H x D)	22.5 x 85.6 x 105 mm (excluding communication connector)
LEDs: Red/yellow/green	Red: Error of module Yellow: Diagnosis available Green: Ready for operation
Supply voltage	24 V DC (+30 % ... -20 %) (19.2 ... 31.2 V DC) including ripple
Supply current (relay activated)	VI150.0: Max. 40 mA (at 19.2 ... 31.2 V DC) VI155.0: Max. 55 mA (at 19.2 ... 31.2 V DC)
Tightening torque for the input, output and supply terminals	see DX1xx module
Tightening torque for the communication terminals	see DX1xx module
Net weight	0.148 kg (0.326 lb)
Degree of protection	IP20
Temperature range	storage -25 ... +70 °C operation 0 ... +60 °C
Marks, Approvals	CE, cULus, EAC

Relay Outputs

Number of relay outputs	1 DO0 with root DOC
Voltage range of contacts	12-250 V AC/DC
U_{imp}	4 kV
Other technical data for the relay outputs see the DX1xx module	

Voltage Inputs L1, L2, L3

Overvoltage category	III in grounded networks
	II in ungrounded networks
Nominal input range	90 - 690 V AC (three-phase mode) 90 - 400 V AC (single-phase mode)
U_{imp}	8 kV
Voltage measuring in the nominal input range	+/- 2 %
Power factor: 0.4 ... 0.95	+/- 5 % typ. for $I > 0.75$ A
Real power kW	+/- 5 % typ.
Energy kWh	+/- 5 % typ.
THD %	5% typ.
Rated Operational Voltage U_e	690 V AC line to line (three phase mode) 400 V AC line to earth (single phase mode)
Usage in grounded/ungrounded networks	VI155.0 can be used in grounded and ungrounded networks VI150.0 can only be used in grounded networks. See installation instructions in section 2
Voltage supply cables	 Note that the connection cables for voltage measurement may require additional cable protection

AI111.0

General	
Mounting	On DIN rail (EN 50022-35)
Mounting position	Any
Dimensions (W x H x D)	22.5 x 77 x 105.9 mm (excluding communication connector)
LEDs: Red/yellow/green	Red: Hardware error of module Yellow: Diagnosis available Green: Ready for operation
Supply voltage	24 V DC (+30 % ... -20 %) (19.2 ... 31.2 V DC) including ripple
Supply current	Max. 40 mA (at 19.2 ... 31.2 V DC)
Tightening torque for the communication terminals	see section DX1xx
Tightening torque for the input, output and supply terminals	see section DX1xx
Net weight	0.148 kg (0.326 lb)
Degree of protection	IP20
Temperature range	storage -25 ... +70 °C operation 0 ... +60 °C
Marks, Approvals	CE, cULus, EAC Further in preparation. Ask your local sales representative for other marks/ approvals.
Functional isolation between analog inputs and 24 V DC supply / communication interface	yes
Individual configuration of each analog input	yes
U _{imp} sensor analog inputs	0.5 kV
Pollution degree terminals	3

Temperature inputs	
Type of connection	2 or 3 wire
Number of input channels	3 (one AI111.0) / 6 (two AI111.0)
Type of temperature inputs (adjustable per channel)	PT100 -50 °C...+400 °C PT100 -50 °C...+70 °C PT1000 -50 °C...+400 °C KTY83-110 -50 °C...+175 °C KTY84-130 -40 °C...+300 °C NTC +80...+160 °C [B75227-K333-A1]
Accuracy at 20 °C (T20)	≤ ± 2 K
Temperature coefficient	0.1 K per K deviation from T20
Out of range detection	yes
Max. cable length	max. cable resistance: 50R (single wire) [e.g. with copper wire 1.5 mm ² : 1900 m cable length]
Cable shielding	Recommended for up to 30 m and outside the switchgear cabinet; shielding mandatory for cables over 30 m
Update rate	typ. 600 ms
Sensor current (typ.)	PT100 1 mA PT1000/KTY83/KTY84/NTC 0.2 mA

Analog Inputs	
Number of inputs	3 (one AI111.0) / 6 (two AI111.0)
Type of analog inputs (adjustable)	0/4 mA - 20 mA / 0-10 V
Resolution	15 Bit
Measuring ranges	
0...20 mA and 0...10 V	0 27648 dec (6C00 hex)
4...20 mA	0 27648 dec (6C00 hex)
Max. input current for 0/4-20 mA	60 mA (destruction limit)
Accuracy at 20 °C (T20)	±1 % from full scale value
Temperature coefficient	0.05/K deviation from T20
Input resistance	≤ 300 Ohm at 0/4 -20 mA ≥ 10 kOhm at 0-10 V
Wire break detection	In operation mode: 4-20 mA
Cable shielding	Recommended for up to 30 m and outside the switchgear cabinet; shielding mandatory for cables over 30 m

EMC UMC100.3, AI111.0, DX1xx.0 and VI15x.0

Measurement of radiated and conducted interference according to IEC/EN61131-2 CISPR16-2-3

Class A



Notice:

This product has been designed for environment A. Use of this product in environment B may cause unwanted electromagnetic disturbances in which case the user may be required to take adequate mitigation measures.

Electrostatic discharge	IEC/EN 61000-6-2	8 kV air discharge 6 kV contact discharge
Radiofrequency electromagnetic field	IEC/EN 61000-6-3	10 V/m
Fast transient bursts	IEC/EN 61000-6-4	2 kV power supply
High energy surges	IEC/EN 61000-6-5	1SAJ53000R1***: 2/1 kv CM/DM Others: 1/0.5 kv CM/DM
Conducted radio frequency interference	IEC/EN 61000-6-6	10 V

EMC VI15x.0

High energy surges	IEC/EN 61000-4-5	1/0.5 kV CM/DM power supply 2/1 kV CM/DM L1/L2/L3 voltage inputs
Damped oscillatory wave	IEC/EN 61000-4-18	Only voltage inputs L1/L2/L3: 2.5 kV / 1 kV CM / DM
Immunity low frequency harmonics	IEC/EN 61000-4-11	Power supply: 50 ... 12 kHz, 3 V

Operational altitude above sea level

Device	Conditions	Operational altitude above sea level	Relay output derating factor	
UMC100.3	all types	2000-5000 m max. +40 °C motor voltage 480-690 V with isolated wires	>2000 m: 0.9 >3000 m: 0.8 >4000 m: 0.7	
Control panel	UMC100-PAN			
Communication interfaces				
Profibus DP	PDP32.0			
Profinet IO	MTQ22.0			
Ethernet/IP™	EIU32.0			
Expansion modules				
Voltage module	VI150.0		NC terminals shall be disconnect	>2000 m: 0.9 >3000 m: 0.8 >4000 m: 0.7
Voltage module	VI155.0		NC terminals shall be disconnect	
Analog module	AI111.0			
Earth fault monitors	CEM11-FBP.xxx		isolated wires shall always be used	
Current transformers	CT4Lxxxxxx			
	CT5Lxxxxxx			

Characteristic values according to IEC/EN 61508

The following characteristic values apply at an ambient temperature of 40 °C and AC load with spark suppression circuits at the relay outputs. Characteristic values for other operating conditions are available on request.

	UMC100.3 DC	UMC100.3 UC
Architecture	1oo1 with diagnosis	1oo1 with diagnosis
SIL	1	1
SFF (Safe Failure Fraction)	84.8 %	87.3 %
Lambda dangerous undetected (LDU)	1.65×10^{-7}	1.93×10^{-7}
Lambda dangerous detected (LDD)	4.16×10^{-7}	4.25×10^{-7}
Lambda safe undetected (LSU)	3.74×10^{-7}	7.76×10^{-7}
Lambda safe detected (LSD)	1.31×10^{-7}	1.32×10^{-7}
Safety requirements	Low demand	Low demand
Probability of failure on demand (PFD)		
at $T_1 = 10$ years	7.23×10^{-3}	8.47×10^{-3}
at $T_1 = 3$ years	2.2×10^{-3}	2.5×10^{-3}

T_1 = proof test

Characteristic values according to ISO 13849

The following characteristic values apply at an ambient temperature of 40 °C and AC load with spark suppression circuits at the relay outputs. Characteristic values for other operating conditions are available on request.

	UMC100.3 DC	UMC100.3 UC
Category	2	2
Performance Level	C	C
MTTFd	196.6 years	184.7 years
MTBF	73.6 years	57.3 years

Dimensional drawings

UMC

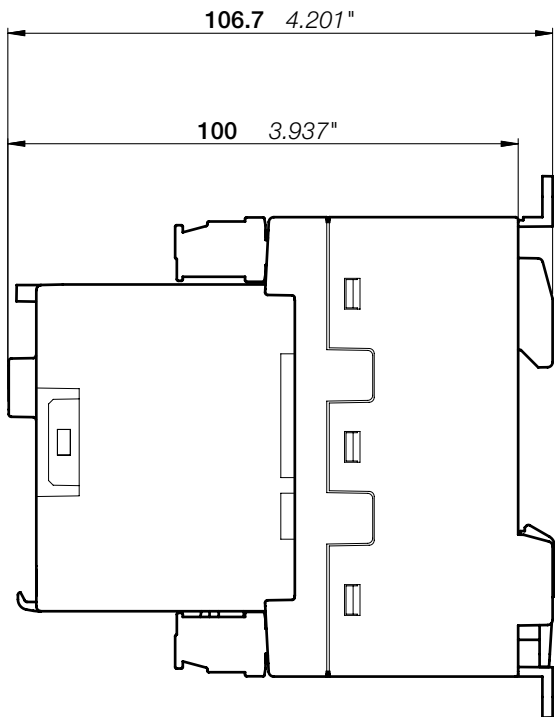

UMC100.3 DC

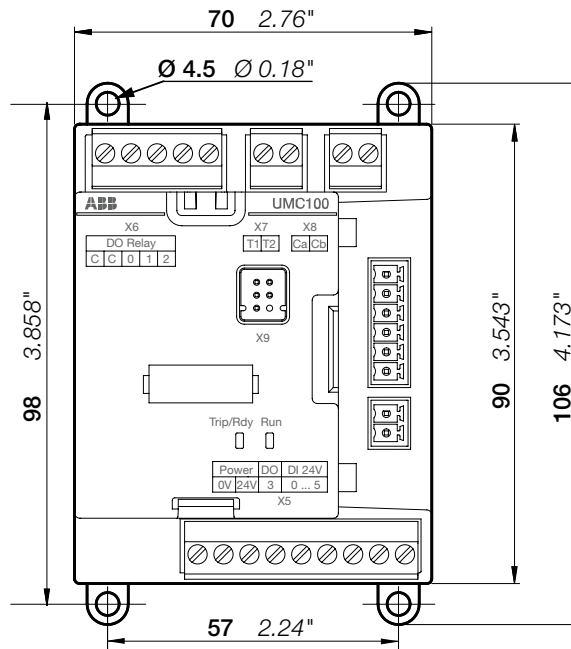

2CDC342001F0014

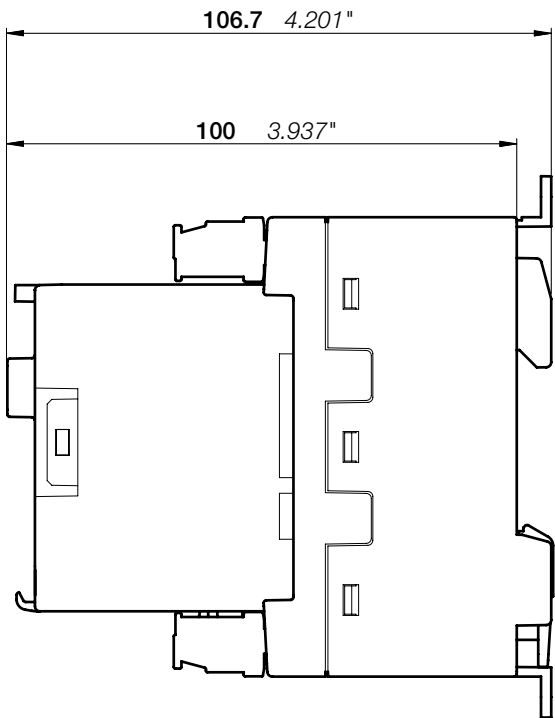

UMC100.3 UC

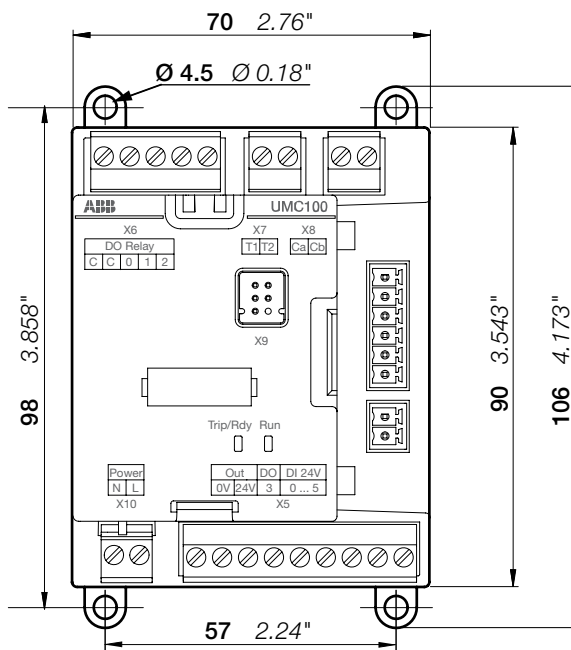

2CDC342004F0014

Expansion modules

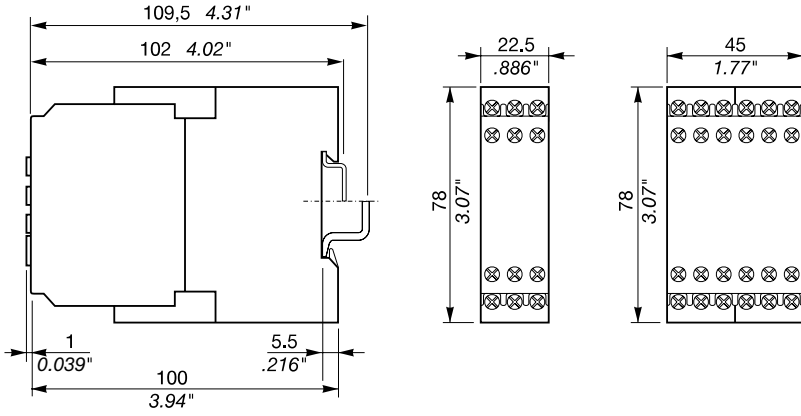

—
VI150.0
VI155.0
AI111.0

—
DX111.0,
DX122.0

—
DX111.0, DX122.0
VI150.0, VI155.0
AI111.0

Operating panel

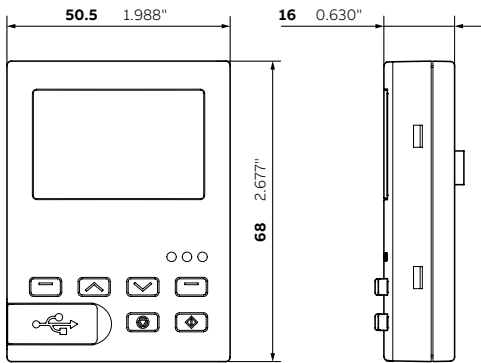

—
UMC100.3-PAN

Operating panel protection cap

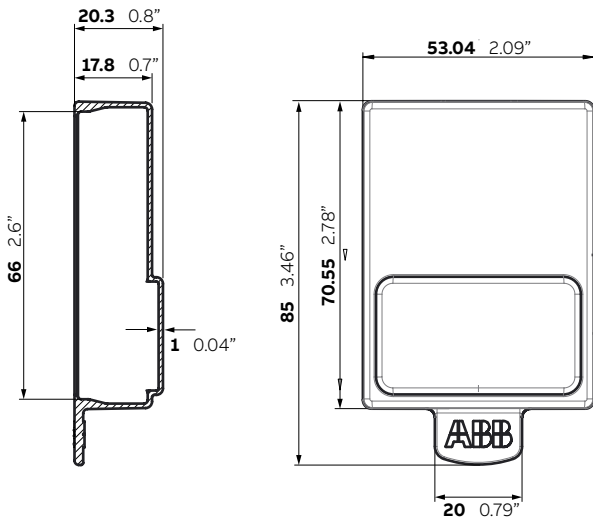

—
UMC100-PAN CAP

Ethernet communication interfaces

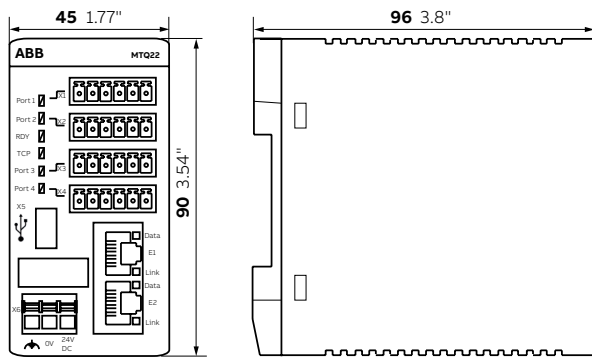

MTQ22.0
PNQ22.0

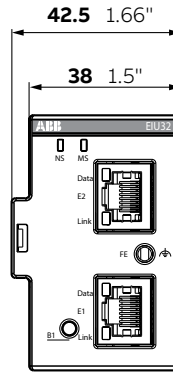

EIU32.0
PNU32.0

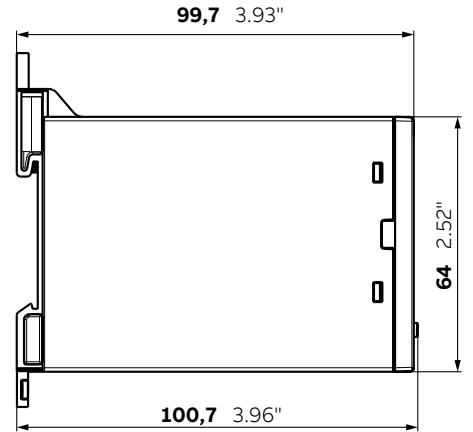

Fieldbus communication interfaces

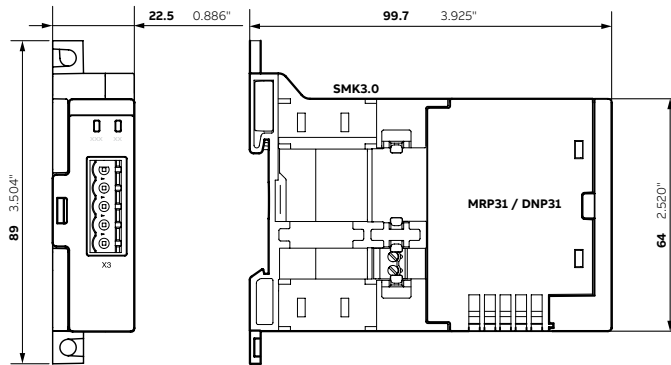

DNP31.0, MRP31.0, SMK3.0

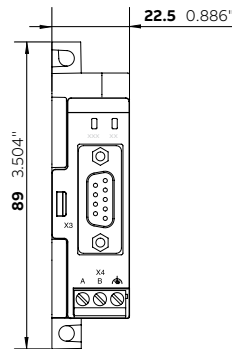

PDP32.0, PDR31.0



ABB AG
STOTZ-KONTAKT

Eppelheimer Strasse 82
69123 Heidelberg
Germany

**You can find the address of your local
sales organization on the ABB homepage**

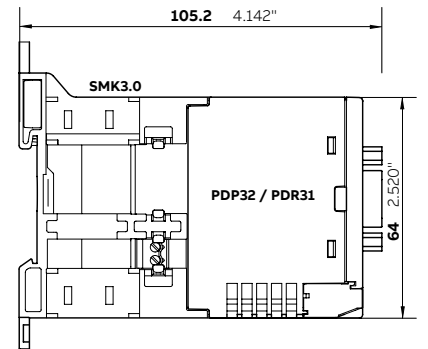

abb.com/lowvoltage

Additional information

We reserve the right to make technical changes or modify the contents of this document without prior notice. With regard to purchase orders, the agreed particulars shall prevail. ABB AG does not accept any responsibility whatsoever for potential errors or possible lack of information in this document.

We reserve all rights in this document and in the subject matter and illustrations contained therein. Any reproduction, disclosure to third parties or utilization of its contents – in whole or in parts – is forbidden without prior written consent of ABB AG.
Copyright© 2025 ABB
All rights reserved