

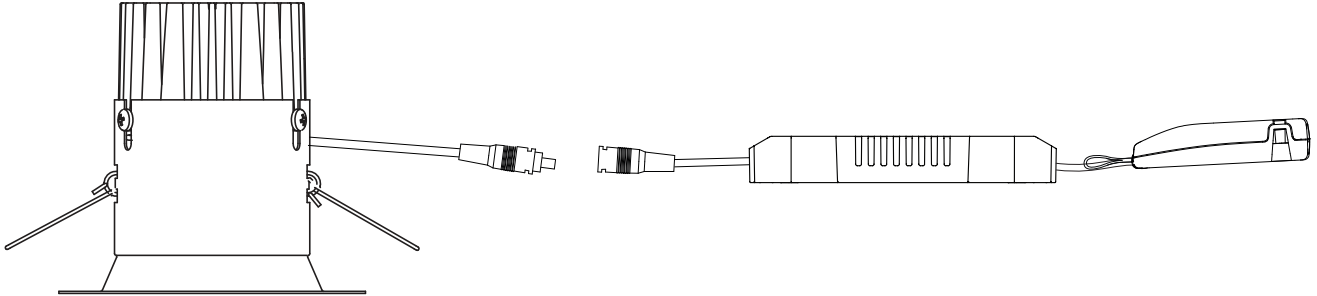

# Jupiter Pro Soft Dali

CE UK CA IP20 IP44 IP65 DALI-2

220-240V, 50/60Hz



	Jupiter Pro	Rehab 180	Rehab 250	Rehab 300
	Ø83 mm	Ø83-160 mm	Ø170-230 mm	Ø255-280

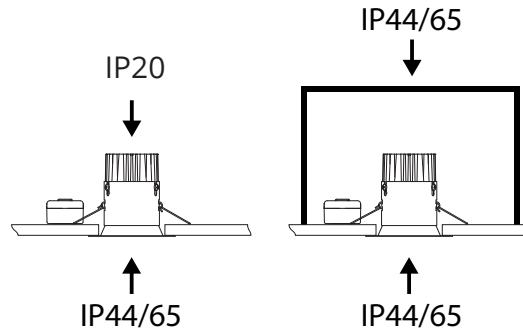
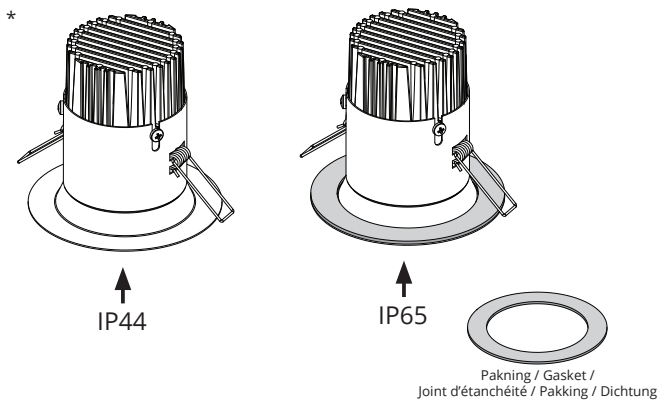
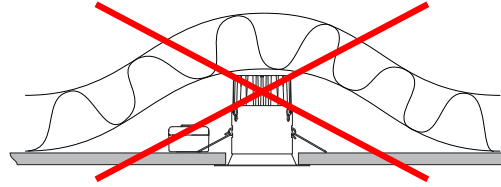
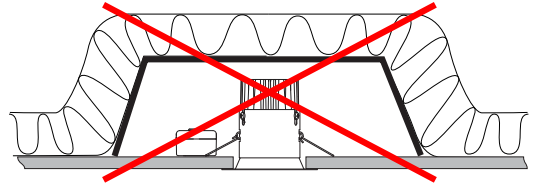
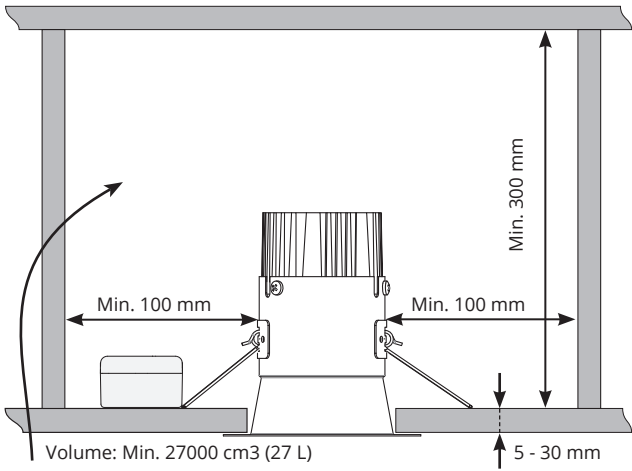

**NORWAY**  
SG Armaturen AS

Skytterheia 25  
N-4790 Lillesand

Tel: +47 37 50 03 00  
firmapost@sg-as.no  
www.sg-as.no

**SWEDEN**  
SG Armaturen AB  
Tel: +46 31 81 71 10  
info@sg-ab.se  
www.sg-ab.se

**DENMARK**  
SG Armaturen A/S  
Tel: +45 70 70 72 13  
info@sg-as.dk  
www.sg-as.dk

**GERMANY**  
SG Leuchten GmbH  
Tel: +49 40 23 99 44 59  
info@sg-leuchten.de  
www.sg-leuchten.de

**FINLAND**  
SG Armaturen Oy  
Tel: +358 02 07 30 39 60  
info@sg-oy.fi  
www.sg-oy.fi

**FRANCE**  
SG Lighting SA/NV  
Tel: +33(0) 4 94 93 00 00  
info.france@sglighting.fr  
www.sglighting.net

**BENELUX**  
SG Lighting SA/NV  
Tel: +32(0) 15 20 72 71  
info.benelux@sglighting.net  
www.sglighting.net

**SWITZERLAND**  
SG Leuchten SA  
Tel: +41 44 868 20 00  
info@sg-leuchten.ch  
www.sg-leuchten.ch

**INTERNATIONAL**  
SG Lighting Co Ltd.  
Tel: +86 769 88 49 20 88  
cindy@sgdgc.com  
www.sg-as.com

Dipswitch  
Jupiter Pro Soft 1500

Standard

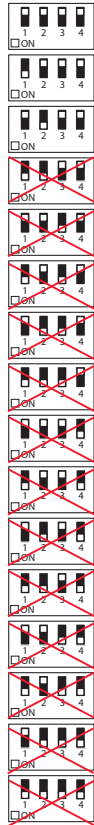

	mA	lm
	300	86%
	<b>350</b>	<b>100%</b>
	400	114%
	450	-
	500	-
	550	-
	600	-
	650	-
	700	-
	750	-
	800	-
	850	-
	900	-
	950	-
	1000	-
	1050	-

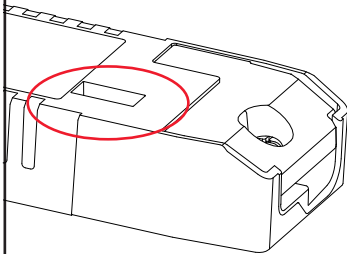

Dipswitch  
Jupiter Pro Soft 2200

Standard

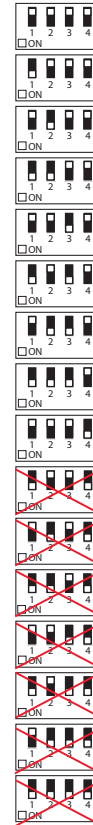

	mA	lm
	300	60%
	350	70%
	400	80%
	450	90%
	500	<b>100%</b>
	550	110%
	600	120%
	650	130%
	700	140%
	750	-
	800	-
	850	-
	900	-
	950	-
	1000	-
	1050	-



Push Dim

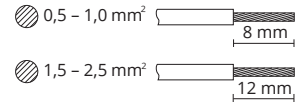
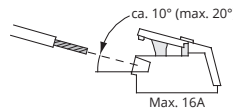
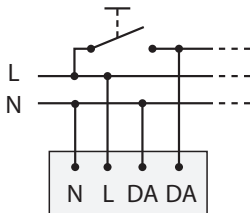

DALI Dim

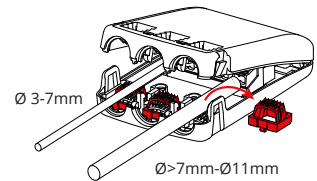
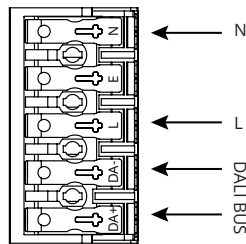
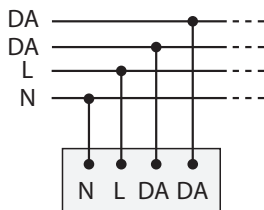

Replaceable light source  
by a professional



Replaceable control gear  
by a professional

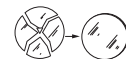

**NO:** Kan kun installeres og vedlikeholdes av en registrert installasjonsvirksomhet.  
**DK:** Må kun installeres og vedlikeholdes af uddannet elektriker.  
**SE:** Skall installeras och underhållas av behörig elektriker.  
**EN:** Only to be installed and maintained by an authorized electrician.  
**FR:** Doit être installé et maintenu par un électricien qualifié.  
**NL:** Mag alleen geïnstalleerd en onderhouden worden door een bevoegde elektricien.  
**DE:** Dieses Produkt darf nur durch autorisiertes Personal (z.B. Elektro-Installateur) angeschlossen, in Betrieb genommen und gewartet werden.  
**FI:** Asentaa ja huoltaa saa vain valtuutettu sähköasentaja

**NO:** Skru av strømmen før montering.  
**DK:** Sluk for strømmen inden montering.  
**SE:** Stäng av strømmen innan montering.  
**EN:** Turn off power before installing.  
**FR:** Couper le courant avant l'installation.  
**NL:** Stroom uitschakelen voor u het toestel installeert.  
**DE:** Vor Installationsarbeiten den Strom abschalten.  
**FI:** Sammuta virta ennen kytkemistä

**NO:** Skadet glass må erstattes med nytt.  
**EN:** Damaged glass must be replaced.  
**DK:** Beskadiget glas skal udskiftes  
**SE:** Skadat glas måste ersättas med nytt.  
**FR:** Tout verre endommagé doit être remplacé.  
**NL:** Gebroken glas moet vervangen worden.  
**DE:** Glasscherben müssen ausgetauscht werden.  
**FI:** Vaurioitunut lasi on vaihdettava