

Positionsmeldeschalter

Position signaling switch

Contact de signalisation de position

Interruptor de señalización de posición

Contatti di segnalazione posizione

Chave sinalizadora de posição

Pozisyon bildirim şalteri

Выключатель положения с сигнальными контактами

Przełącznik zgłaszania pozycji

位置信息开关

3VA9987 - 0KB00



IEC 60947

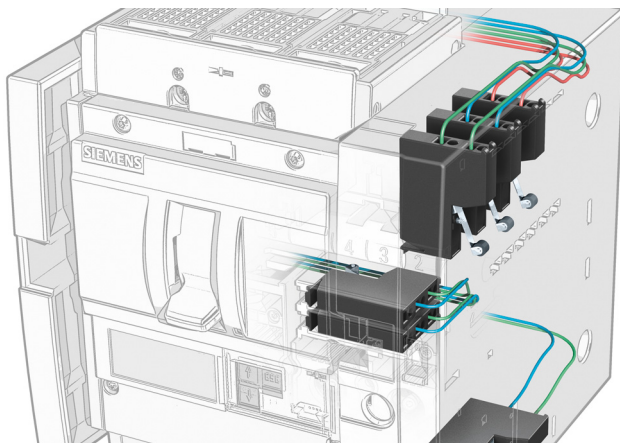

Betriebsanleitung

Operating Instructions

Instructions de service

Instructivo

Istruzioni operative

Instruções de Serviço

İşletme kılavuzu

Руководство по эксплуатации

Instrukcja obsługi

使用说明

DE	GEFAHR	Gefährliche Spannung. Lebensgefahr oder schwere Verletzungsgefahr. Vor Beginn der Arbeiten Anlage und Gerät spannungsfrei schalten.
EN	DANGER	Hazardous voltage. Will cause death or serious injury. Turn off and lock out all power supplying this device before working on this device.
FR	DANGER	Tension électrique. Danger de mort ou risque de blessures graves. Mettre hors tension avant d'intervenir sur l'appareil.
ES	PELIGRO	Tensión peligrosa. Puede causar la muerte o lesiones graves. Desconectar la alimentación eléctrica antes de trabajar en el equipo.
IT	PERICOLO	Tensione pericolosa. Può provocare morte o lesioni gravi. Scollegare l'alimentazione prima di eseguire interventi sull'apparecchiatura.
PT	PERIGO	Tensão perigosa. Perigo de morte ou ferimentos graves. Desligue a alimentação elétrica e proteja contra o religamento, antes de iniciar o trabalho no equipamento.
TR	TEHLİKE	Tehlikeli gerilim. Ölüm tehlikesi veya ağır yaralanma tehlikesi. Çalışmalara başlamadan önce, sistemin ve cihazın gerilim beslemesini kapatınız.
PY	OPACHO	Opasnoe napryazhenie. Opasnost' dlya zhizni ili vozmozhnost' tyazhelykh travm. Перед началом работ отключить подачу питания к установке и к устройству.
PL	ZAGROŻENIE	Niebezpieczne napięcie. Niebezpieczeństwo poważnych obrażeń lub utraty życia. Przed rozpoczęciem prac wyłączyć zasilanie instalacji i urządzenia energią elektryczną.
中文	危险	危险电压。可能导致生命危险或重伤危险。 操作设备时必须确保切断电源。

Technical Support:	Internet: http://www.siemens.com/lowvoltage/technical-support
--------------------	---



Notwendige Werkzeuge / Necessary tools / Outils nécessaires / Herramientas requeridas / 必要工具

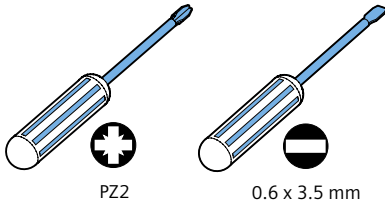

PZ2

0.6 x 3.5 mm



Lieferumfang / Scope of Delivery / Etendue de la livraison / Alcance de suministro / 供货范围

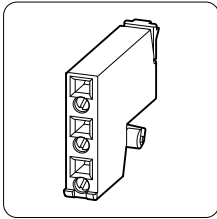

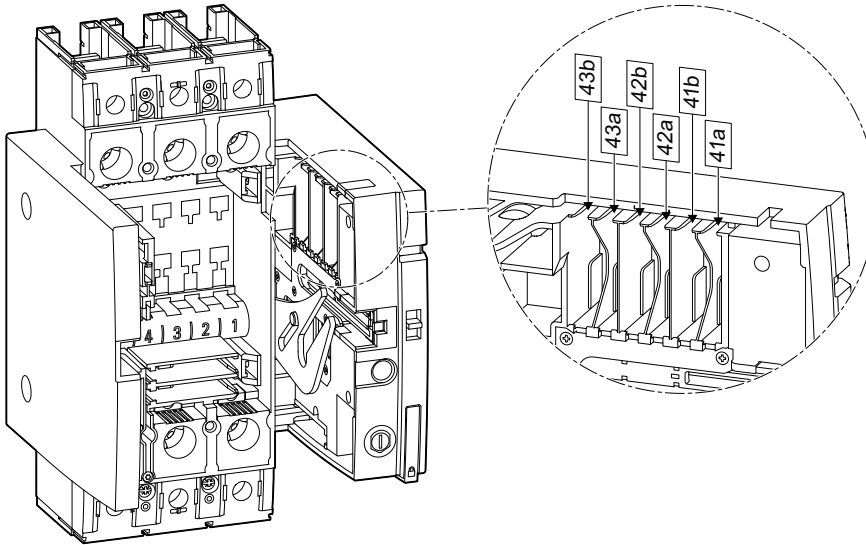

Information / Information / Information / Información / 信息

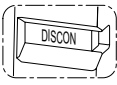
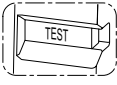
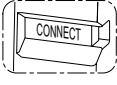

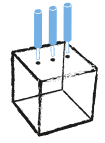
 41a / 41b	DE	ausgefahren	PT	extraída
	EN	Disconnected	TR	dışarı çıktı
	FR	débroché	РУ	разъезженный
	ES	extraído	PL	wysunięty
	IT	estratto	中文	已驶出
 42a / 42b	DE	Teststellung	PT	Posição de teste
	EN	Test position	TR	Test konumu
	FR	position d'essai	РУ	Испытательное положение
	ES	Posición de Prueba	PL	Instalacja testowa
	IT	Posizione di test	中文	试验位置
 43a / 43b	DE	eingefahren	PT	inserida
	EN	Connected	TR	içeri girdi
	FR	embroché	РУ	втянутый
	ES	insertado	PL	schowany
	IT	rientrato	中文	已驶入

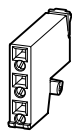

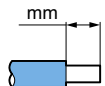
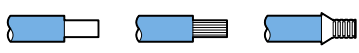
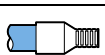



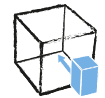
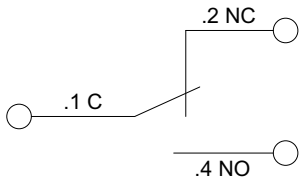
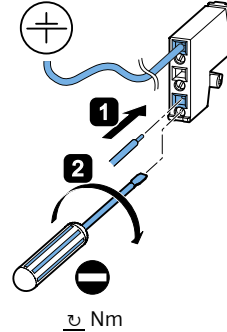



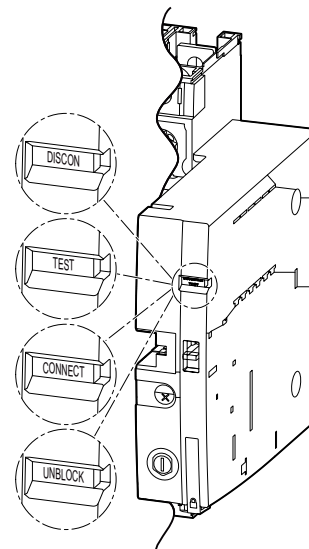
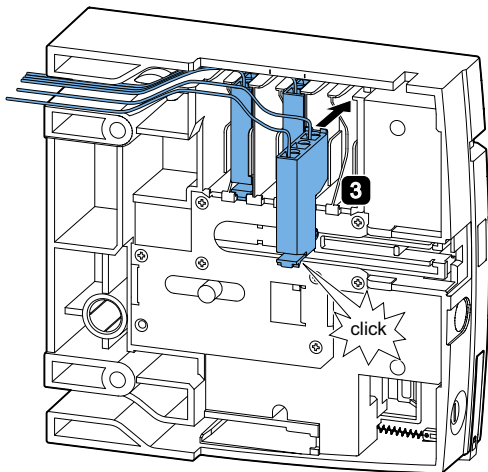

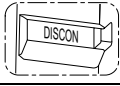
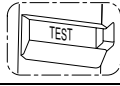
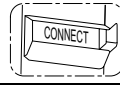
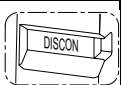





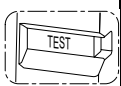





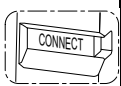

			
	mm ²	τ /Nm	mm
	1x (0.5 ... 1.5)	0.4 ... 0.5	10
	1x (0.5 ... 1.0)		

max. 250V AC12 6A / 80V DC12 0.1A

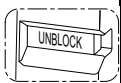

3VA9... - 0KD00



						
	41		42		43	
	NO	NC	NO	NC	NO	NC
						
						
						
						



3VA9... - OKD00

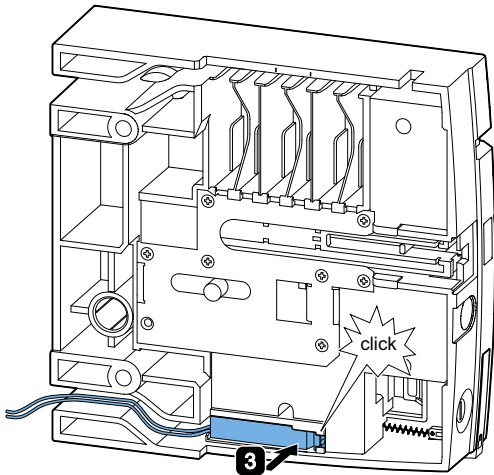

	NO	NC

3VA9... - OKP00

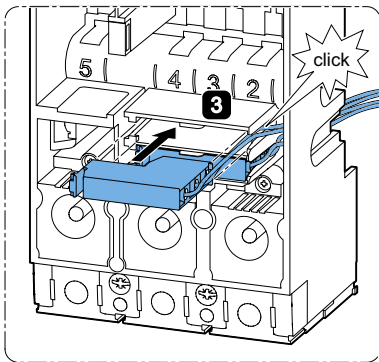

	NO	NC