

Einschubeinheit, Kommunikationsanbindung

Draw-out unit, Communication link

Unité débrochable, interface de communication

Unidad extraíble, conexión para comunicación

Unità estraibile, Collegamento di comunicazione

Unidade de inserção, conexão para comunicação

Modül ünitesi, iletişim bağlantısı

Выдвижной блок, коммуникационное соединение

Człon wsuwany, połączenie komunikacyjne

卡入式结构单元, 通信连接

3VA9987 - 0KC00



IEC 60947

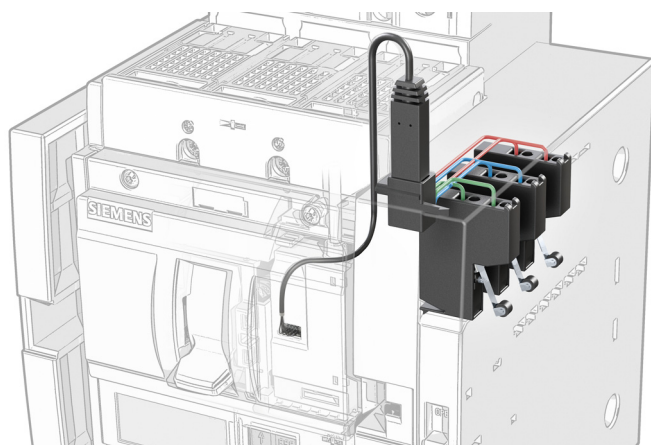

Betriebsanleitung

Operating Instructions

Instructions de service

Instructivo

Istruzioni operative

Instruções de Serviço

İşletme kılavuzu

Руководство по эксплуатации

Instrukcja obsługi

使用说明

DE	GEFAHR	Gefährliche Spannung. Lebensgefahr oder schwere Verletzungsgefahr. Vor Beginn der Arbeiten Anlage und Gerät spannungsfrei schalten.
EN	DANGER	Hazardous voltage. Will cause death or serious injury. Turn off and lock out all power supplying this device before working on this device.
FR	DANGER	Tension électrique. Danger de mort ou risque de blessures graves. Mettre hors tension avant d'intervenir sur l'appareil.
ES	PELIGRO	Tensión peligrosa. Puede causar la muerte o lesiones graves. Desconectar la alimentación eléctrica antes de trabajar en el equipo.
IT	PERICOLO	Tensione pericolosa. Può provocare morte o lesioni gravi. Scollegare l'alimentazione prima di eseguire interventi sull'apparecchiatura.
PT	PERIGO	Tensão perigosa. Perigo de morte ou ferimentos graves. Desligue a alimentação elétrica e proteja contra o religamento, antes de iniciar o trabalho no equipamento.
TR	TEHLİKE	Tehlikeli gerilim. Ölüm tehlikesi veya ağır yaralanma tehlikesi. Çalışmalara başlamadan önce, sistemin ve cihazın gerilim beslemesini kapatınız.
PY	OPACHO	Opasne naprjajenje. Opasnost za življenje ali možnost težkih travm. Pred началом работ отключить подачу питания к установке и к устройству.
PL	ZAGROŻENIE	Niebezpieczne napięcie. Niebezpieczeństwo poważnych obrażeń lub utraty życia. Przed rozpoczęciem prac wyłączyć zasilanie instalacji i urządzenia energią elektryczną.
中文	危险	危险电压。可能导致生命危险或重伤危险。 操作设备时必须确保切断电源。

Technical Support:	Internet: http://www.siemens.com/lowvoltage/technical-support
--------------------	---



Notwendige Werkzeuge / Necessary tools / Outils nécessaires / Herramientas requeridas / 必要工具

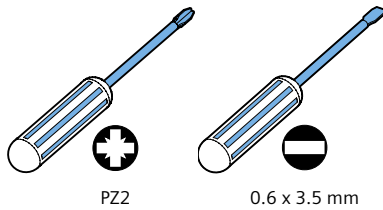

PZ2

0.6 x 3.5 mm



Lieferumfang / Scope of Delivery / Etendue de la livraison / Alcance de suministro / 供货范围

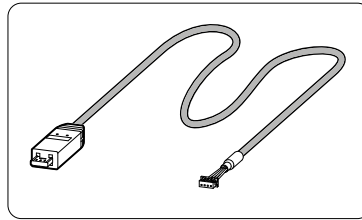
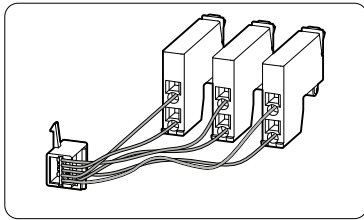

Information / Information / Informations / Información / 信息

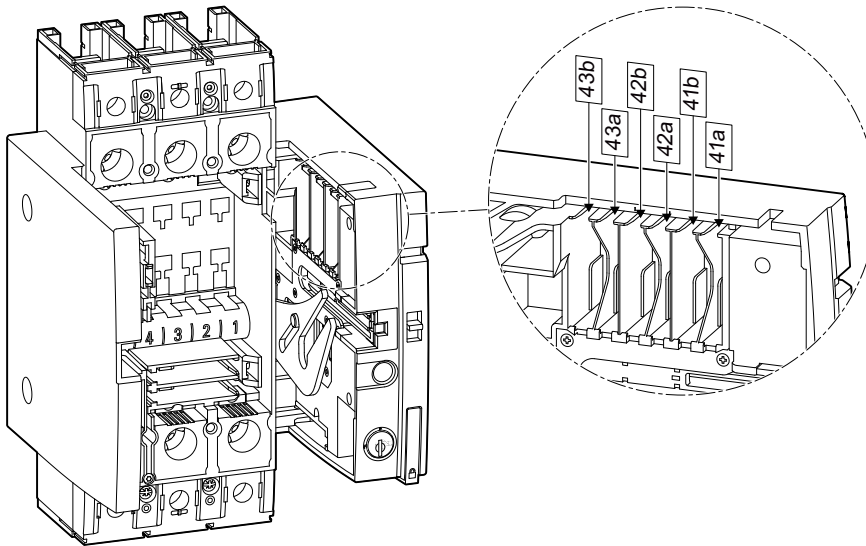

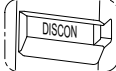
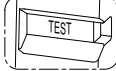
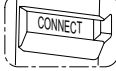
 41a / 41b	DE	ausgefahren, grünes Kabel	PT	extraída, cabo verde
	EN	Disconnected, Green cable	TR	dışarı çıktı, yeşil kablo
	FR	débroché, câble vert	РУ	разъезженный, зеленый кабель
	ES	extraído, cable verde	PL	wysunięty, zielony przewód
	IT	estratto, cavo verde	中文	已驶出, 绿色电缆
 42a / 42b	DE	Teststellung, blaues Kabel	PT	Posição de teste, cabo azul
	EN	Test position, Blue cable	TR	Test konumu, mavı kablo
	FR	position d'essai, câble bleu	РУ	Испытательное положение, синий кабель
	ES	Posición de Prueba, cable azul	PL	Instalacja testowa, niebieski przewód
	IT	Posizione di test, cavo blu	中文	试验位置, 蓝色电缆
 43a / 43b	DE	eingefahren, rotes Kabel	PT	inserida, cabo vermelho
	EN	Connected, Red cable	TR	içeri girdi, kırmızı kablo
	FR	embroché, câble rouge	РУ	втянутый, красный кабель
	ES	insertado, cable rojo	PL	schowany, czerwony przewód
	IT	rietrato, cavo rosso	中文	已驶入, 红色电缆

