

Lasttrennschalter 3KD

3KD Switch-disconnector

Interrupteur-sectionneur 3KD

Interruptor-seccionador 3KD

Sezionatore sottocarico 3KD

Seccionadora sob carga 3KD

Yükleme kesicileri 3KD

Выключатель нагрузки-разъединитель 3KD

Rozłącznik izolacyjny 3KD

3KD 隔离开关

3KD16..-2...

3KD22..-2...

3KD26..-2...

3KD28..-2...

3KD30..-2...

3KD32..-2...

3KD34..-2...



IEC 60947-3

Betriebsanleitung

Operating Instructions

Instructions de service

Instructivo

Istruzioni operative

Instruções de Serviço

İşletme kılavuzu

Руководство по эксплуатации

Instrukcja obsługi

使用说明

DE	GEFAHR	Gefährliche Spannung. Lebensgefahr oder schwere Verletzungsgefahr. Vor Beginn der Arbeiten Anlage und Gerät spannungsfrei schalten.
EN	DANGER	Hazardous voltage. Will cause death or serious injury. Turn off and lock out all power supplying this device before working on this device.
FR	DANGER	Tension électrique. Danger de mort ou risque de blessures graves. Mettre hors tension avant d'intervenir sur l'appareil.
ES	PELIGRO	Tensión peligrosa. Puede causar la muerte o lesiones graves. Desconectar la alimentación eléctrica antes de trabajar en el equipo.
IT	PERICOLO	Tensione pericolosa. Può provocare morte o lesioni gravi. Scolligare l'alimentazione prima di eseguire interventi sull'apparecchiatura.
PT	PERIGO	Tensão perigosa. Perigo de morte ou ferimentos graves. Desligue a alimentação elétrica e proteja contra o religamento, antes de iniciar o trabalho no equipamento.
TR	TEHLİKE	Tehlikeli gerilim. Ölüm tehlikesi veya ağır yaralanma tehlikesi. Çalışmalara başlamadan önce, sistemin ve cihazın gerilim beslemesini kapatınız.
PY	OPACHO	Опасное напряжение. Опасность для жизни или возможность тяжелых травм. Перед началом работ отключить подачу питания к установке и к устройству.
PL	ZAGROŻENIE	Niebezpieczne napięcie. Niebezpieczeństwo poważnych obrażeń lub utraty życia. Przed rozpoczęciem prac wyłączyć zasilanie instalacji i urządzenia energią elektryczną.
中文	危险	危险电压。可能导致生命危险或重伤危险。 操作设备时必须确保切断电源。

Technical Support:

Internet: <http://www.siemens.com/lowvoltage/technical-support>



Notwendige Werkzeuge / Necessary tools / Outils nécessaires / Herramientas requeridas / 必要工具

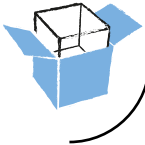
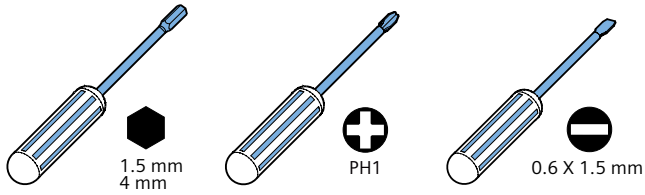

Lieferumfang / Scope of Delivery / Fourniture / Alcance de suministro / 供货范围

3KD16 / 22 / 26

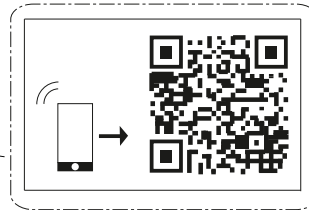
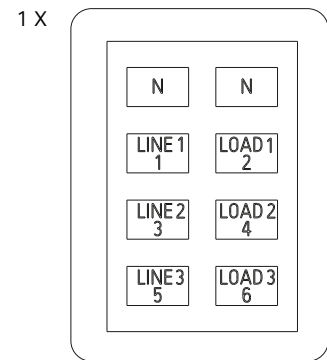
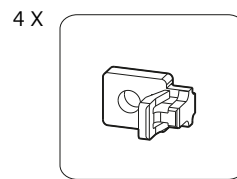
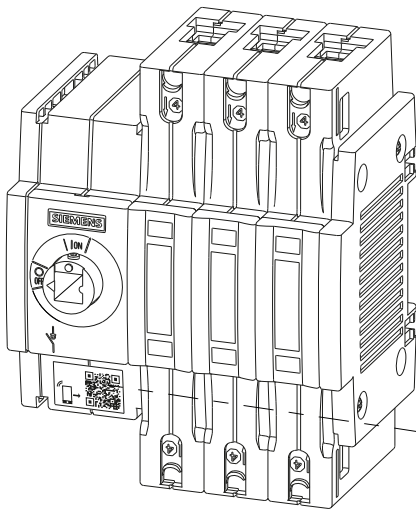

3KD28 / 30 / 32 / 34

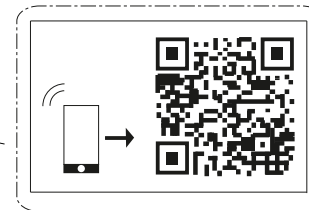
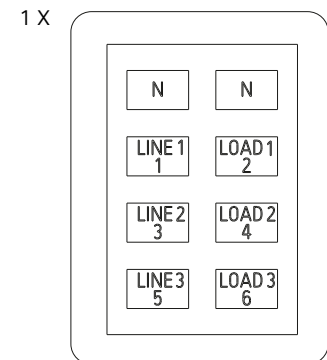
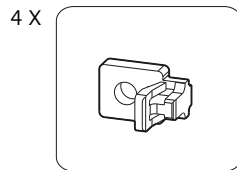
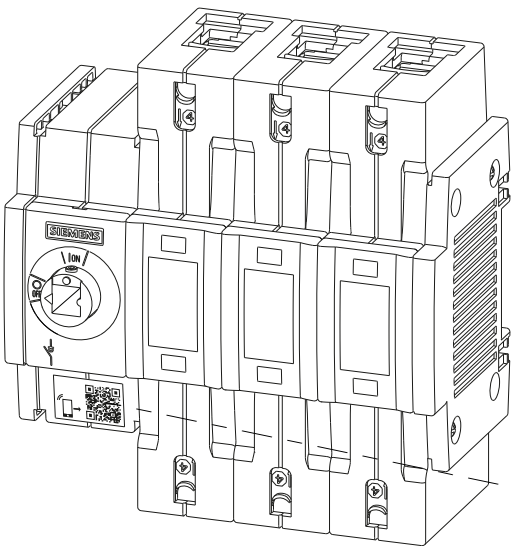

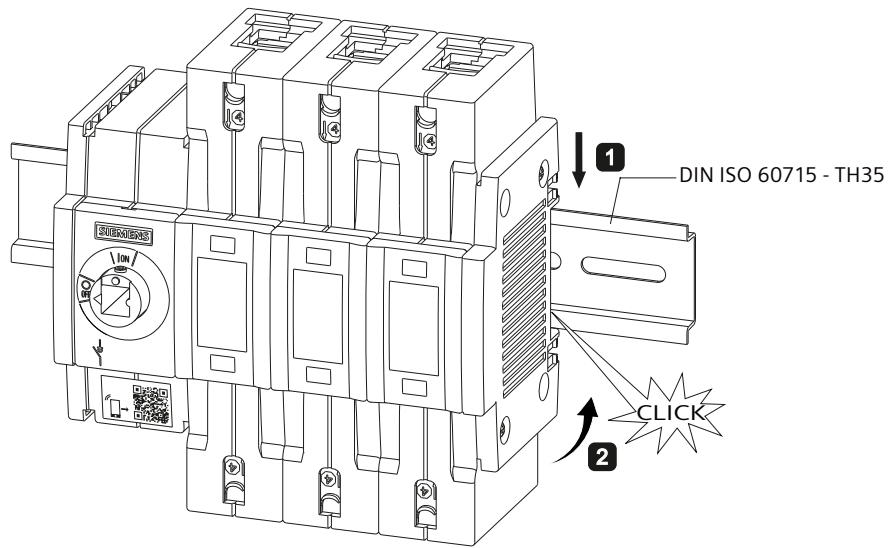
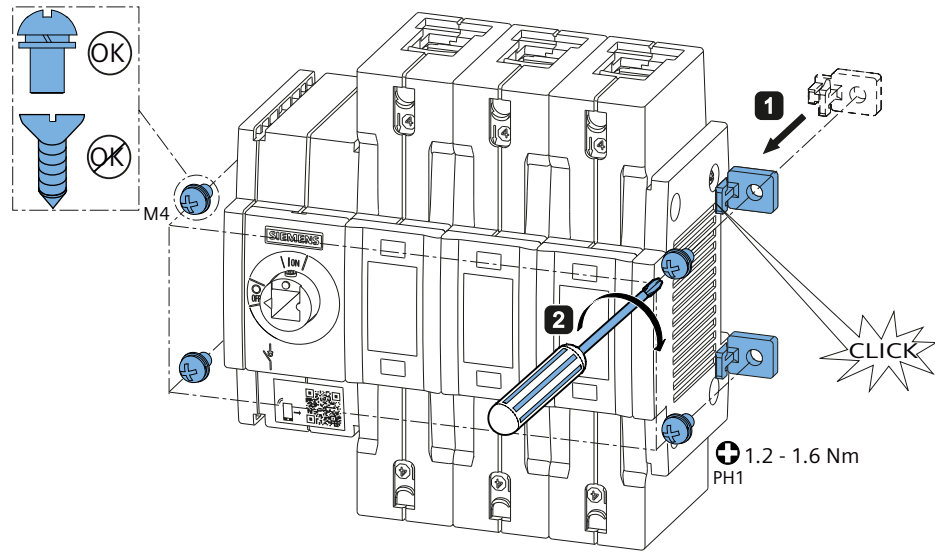
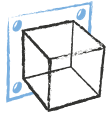

DE	Einbauposition	IT	Posizione di montaggio	PL	Pozycja montażowa
EN	Mounting position	PT	Posição de instalação	中文	安装位置
FR	Position de montage	TR	Montaj pozisyonu		
ES	Posición de montaje	PY	Место установки		

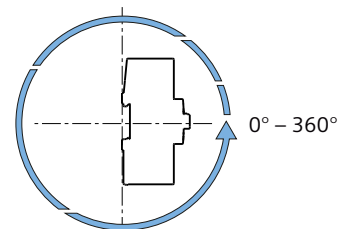
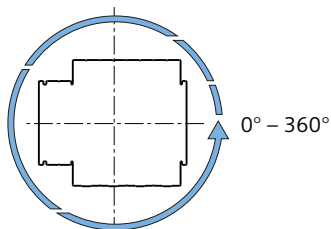

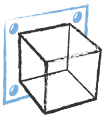

Montage / Assembly / Montaje / Montaj / 安装

DE	Demontage	IT	Smontaggio	PL	Demontaż
EN	Disassembly	PT	Desmontagem	中文	拆卸
FR	Démontage	TR	Demontaj		
ES	Desmontaje	PY	демонтаж		

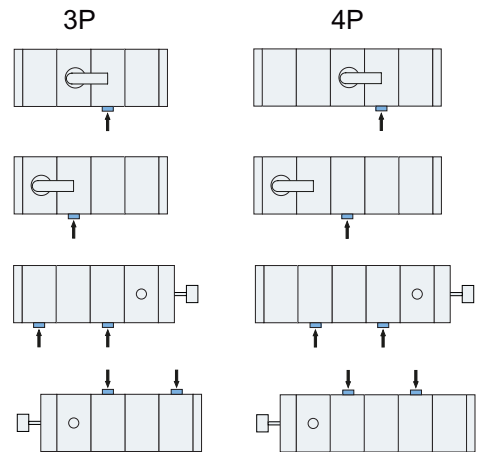
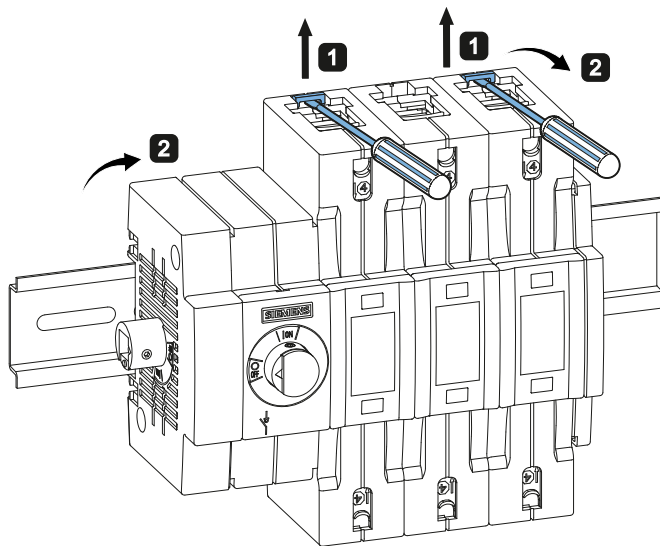
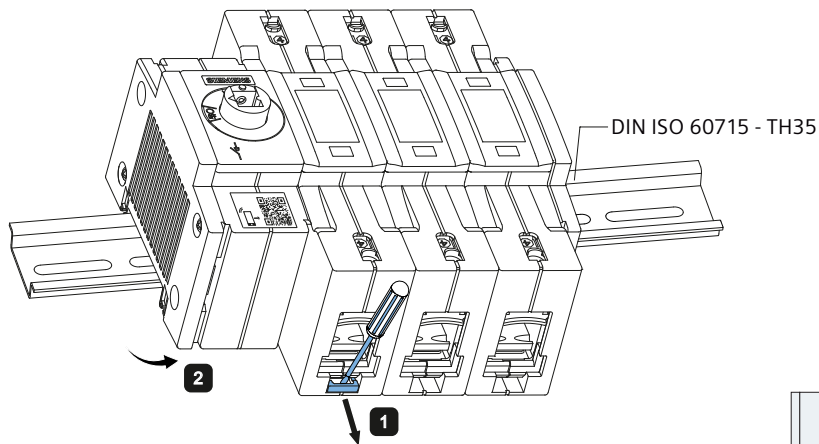

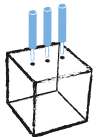
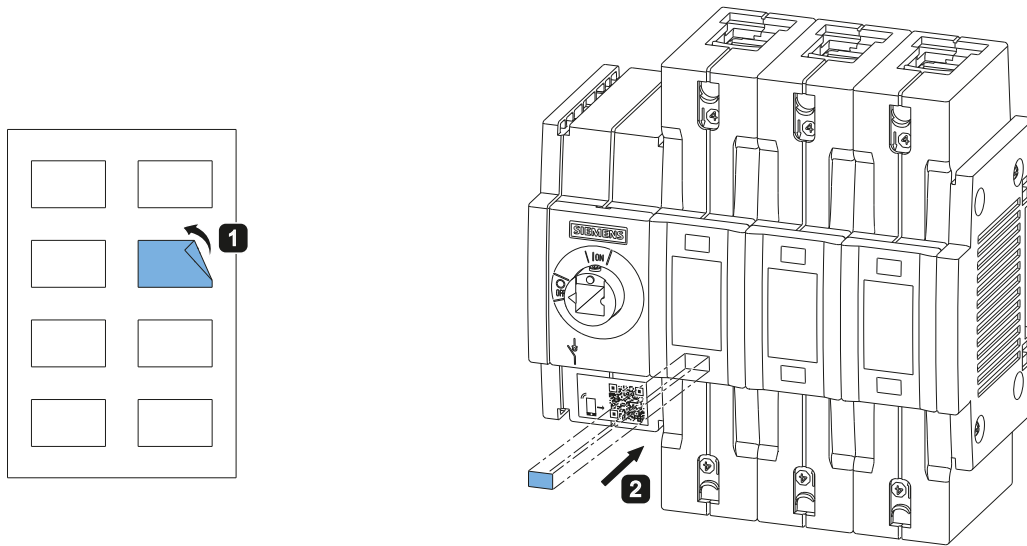

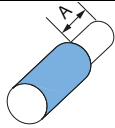
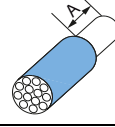
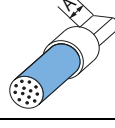
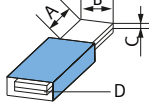
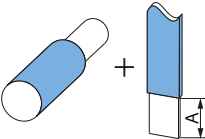
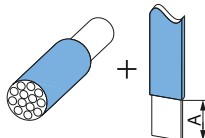
		3KD16 / 22 / 26	3KD28 / 30 / 32 / 34	
	Cu	1 X 1 - 16 mm ²	1 X 2.5 - 16 mm ²	
	A	15 mm	18 mm	
	Cu	1 X 6 - 35 mm ²	1 X 10 - 70 mm ²	
	A	15 mm	18 mm	
	Cu	1 X 1 - 35 mm ²	1 X 2.5 - 70 mm ²	
	A	15 mm	18 mm	
	Cu	A	15 mm	18 mm
		B	9.0 mm	14.0 mm
		C	0.8 mm	0.8 mm
		D	2	3
	Cu	1 X 1 - 16 mm ² + 2 X 9 mm	1 X 2.5 - 16 mm ² + 3 X 14 mm	
	A	15 mm	18 mm	
	Cu	1 X 6 - 35 mm ² + 2 X 9 mm	1 X 10 - 70 mm ² + 3 X 14 mm	
	A	15 mm	18 mm	

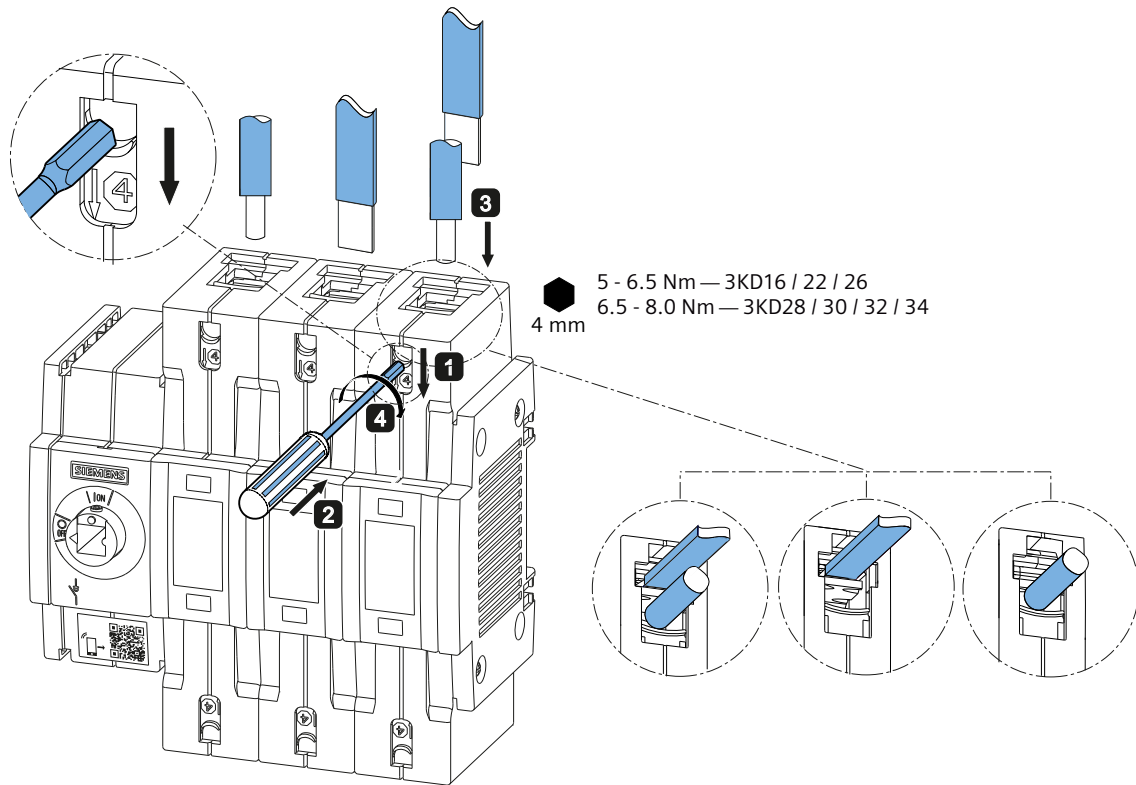
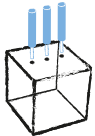



DE	Optionales Zubehör	IT	Accessori opzionali	PL	Aksesoria opcjonalne
EN	Optional accessories	PT	Acessórios opcionais	中文	可选附件
FR	Accessoires optionnels	TR	Opsiyonel aksesuar		
ES	Accesorios opcionales	PY	Опциональная принадлежность		

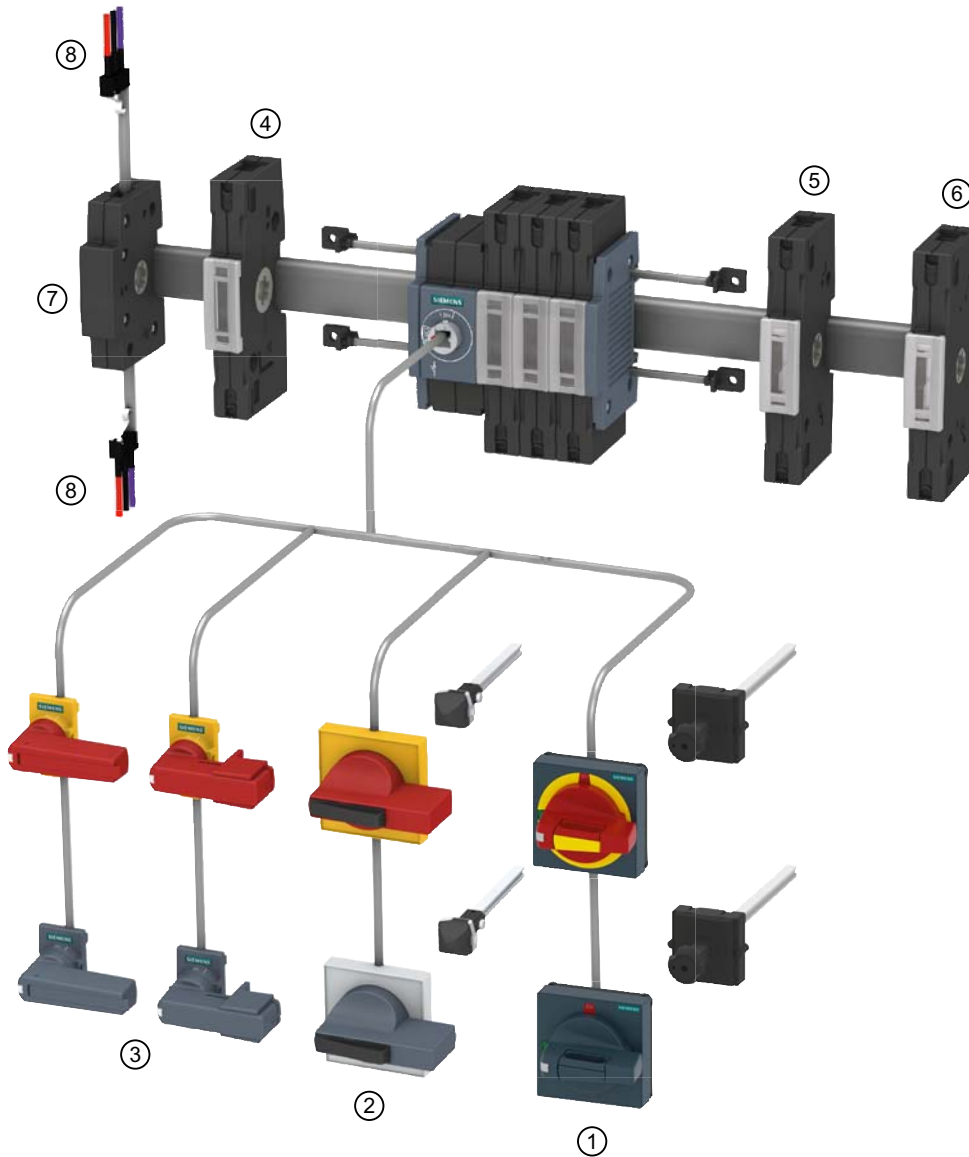



①	Türkupplungsdrehantrieb / Door-coupling rotary operating mechanism / Commande rotative débrayable de porte / Mando giratorio para montaje en puerta / Comando rotativo bloccoporta / Acionamento giratório do acoplamento da porta / Kapı kolu döner tahrik mekanizması / Поворотный привод дверной муфты / Napęd obrotowy sprzęgu drzwi / 门耦合旋转操作手柄	8UD1171-2AD11 8UD1171-2AD15 8UD1171-2AF21 8UD1171-2AF25
---	--	--

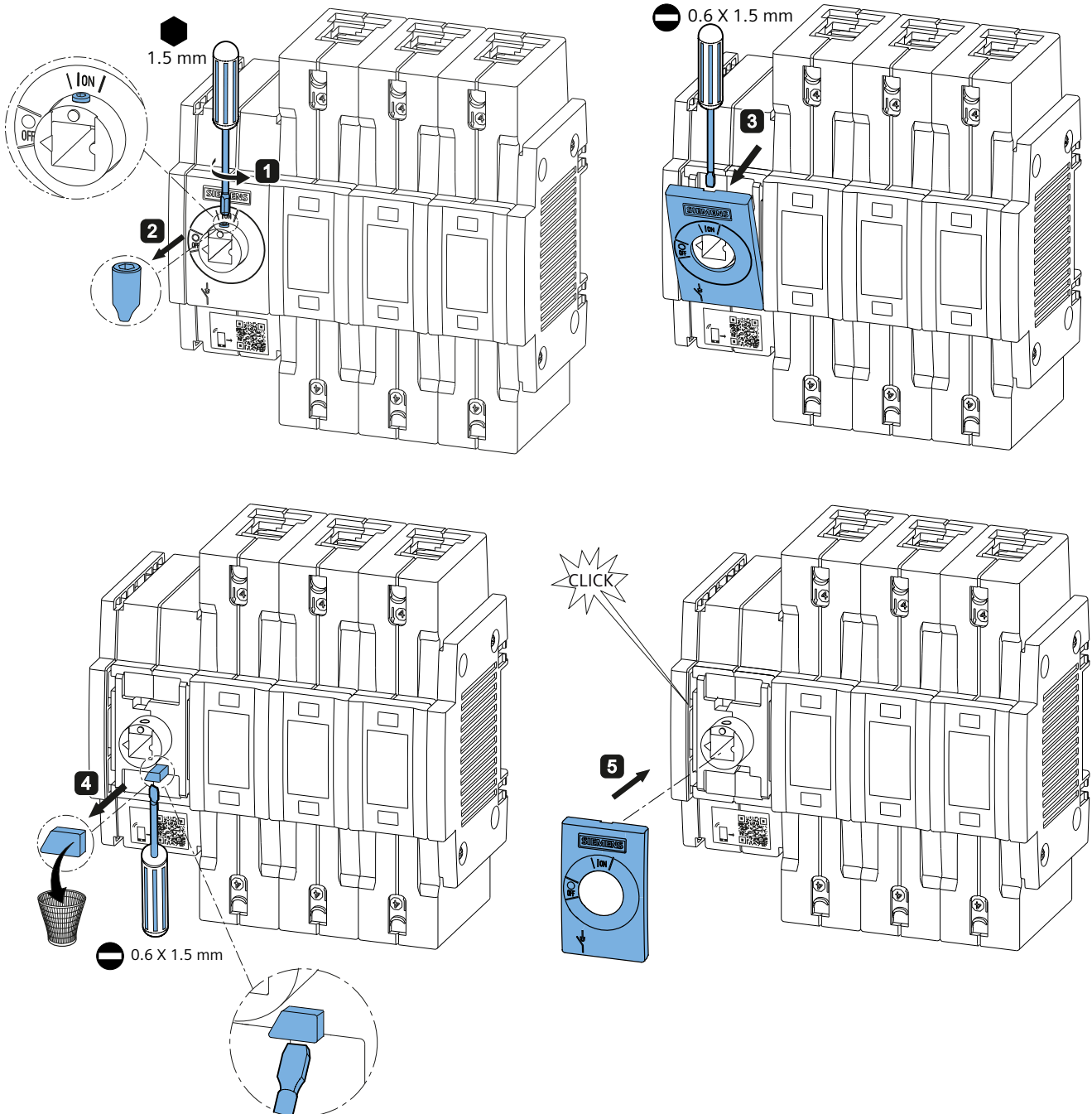

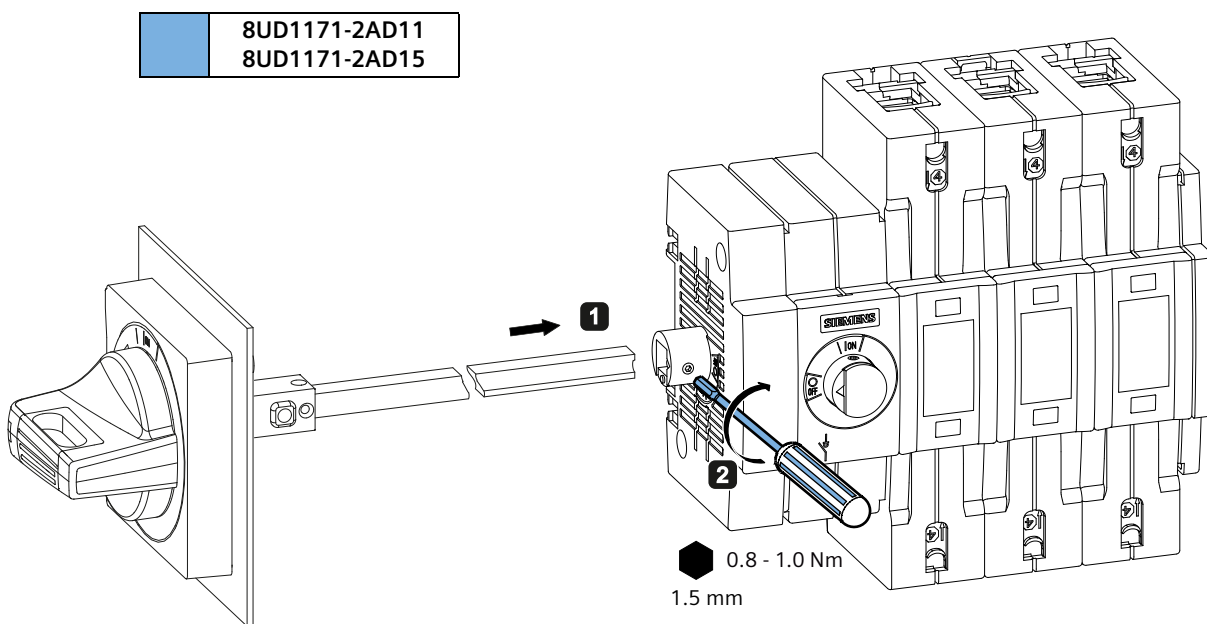
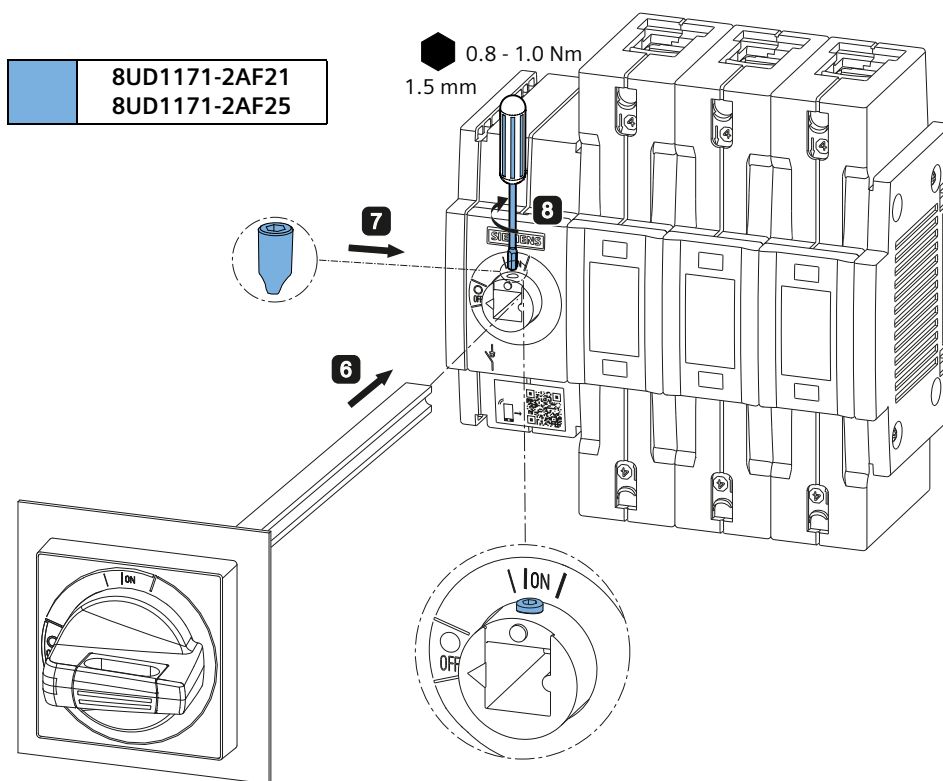



		3KD16 / 22 / 26	3KD28 / 30 / 32 / 34
②	Türkupplungsdrehantrieb / Door-coupling rotary operating mechanism / Commande rotative débrayable de porte / Mando giratorio para montaje en puerta / Comando rotativo bloccoporta / Aacionamento giratório do acoplamento da porta / Kapı kolu döner tahrik mekanizması / Поворотный привод дверной муфты / Napęd obrotowy sprzęgu drzwi / 门耦合旋转操作手柄	3KD9115-1 3KD9115-2 3KD9115-3 3KD9115-4	3KD9215-1 3KD9215-2 3KD9215-3 3KD9215-4

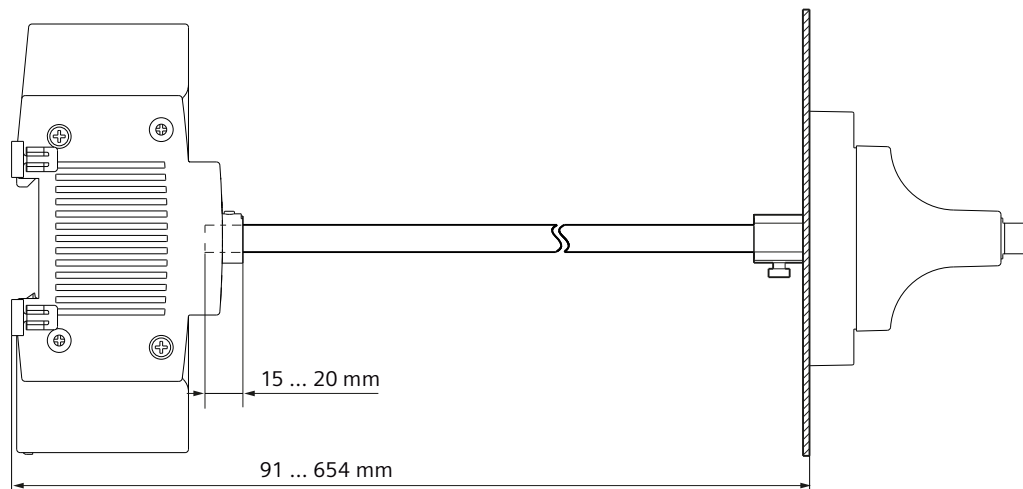
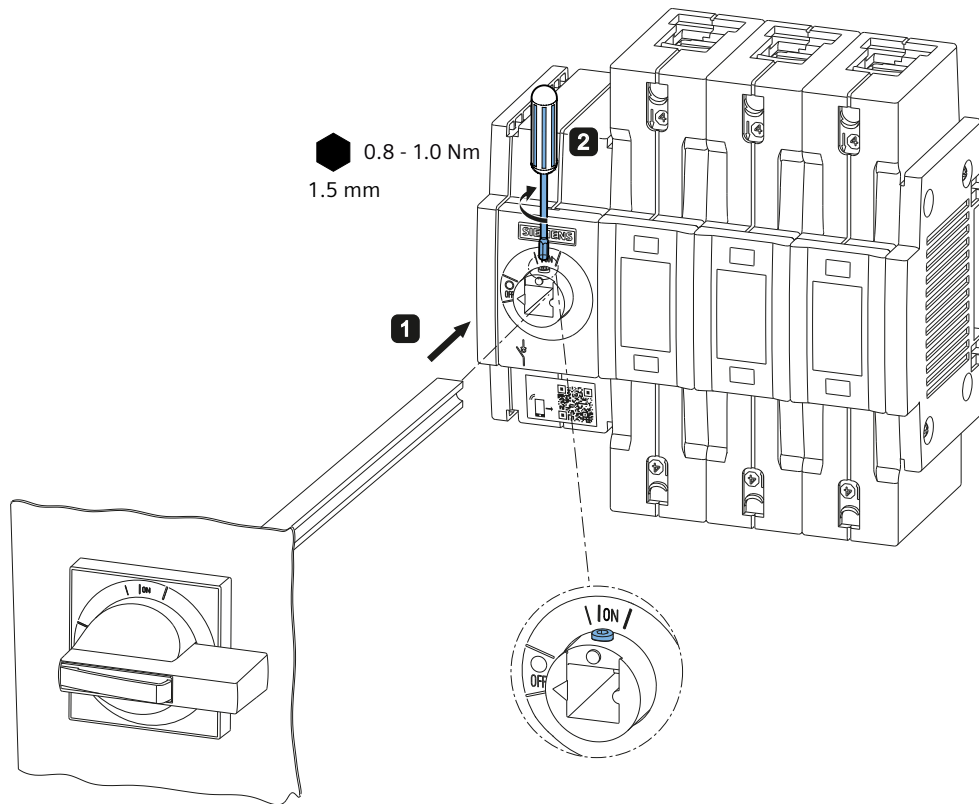



	3KD16 / 22 / 26	3KD28 / 30 / 32 / 34
③	Direktantrieb / Direct handle / Commande directe / Mando directo / Azionamento diretto / Acionamento direto / Direkt tahrik / Прямой привод / Napęd bezpośredni / 直接操作手柄	3KD9201-0 3KD9201-1 3KD9201-2 3KD9201-8

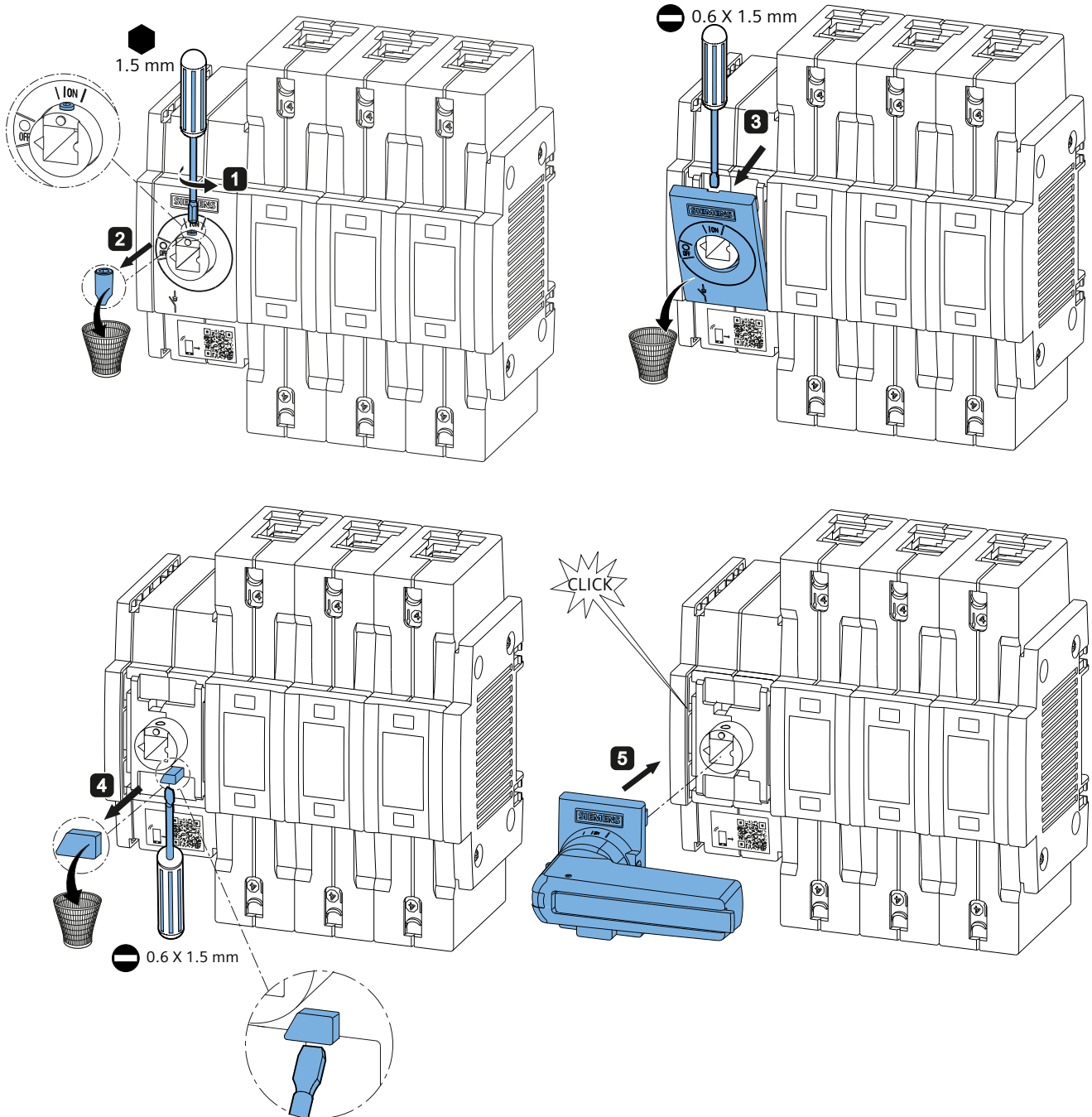

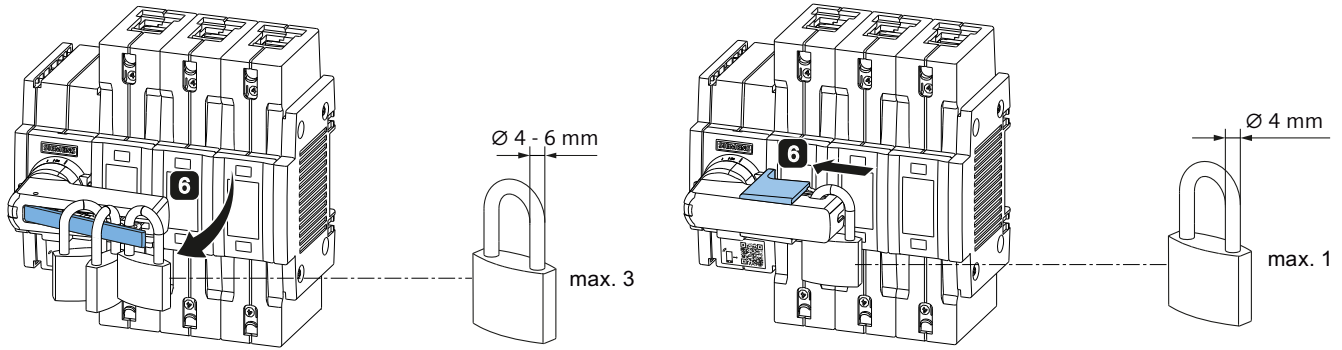

DE	Testfunktion	IT	funzione di test	PL	Funkcja testowa
EN	Test function	PT	função de teste	中文	测试功能
FR	fonction de test	TR	test fonksiyonu		
ES	función de prueba	PV	тестовая функция		

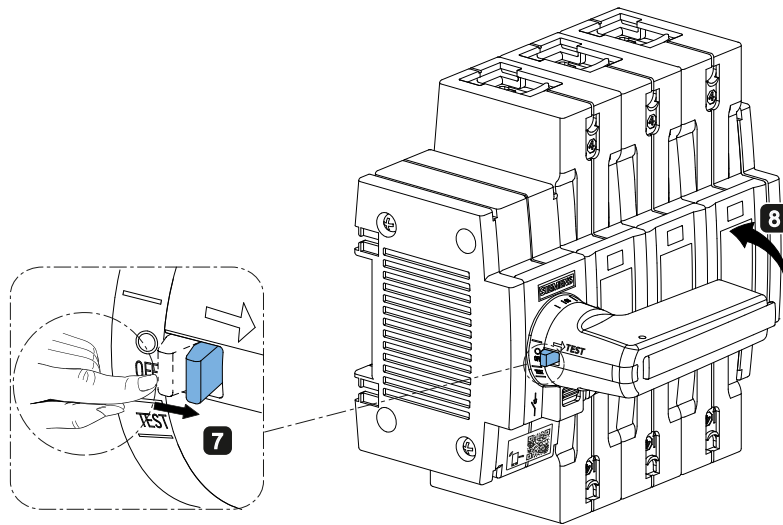

DE	Demontage Handgriff	IT	Smontaggio maniglia	PL	Uchwyt do demontażu
EN	Handle disassembly	PT	Desmontagem do manípulo	中文	拆卸手柄
FR	Poignée de démontage	TR	Tutamak montajı		
ES	Manilla desmontada	PV	Демонтаж рукоятки		

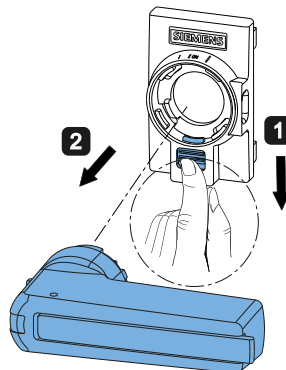



			3KD16 / 22 / 26	3KD28 / 30 / 32 / 34
④	Vierter Pol / 4th pole / Quatrième pôle / Cuarto polo / Quarto polo / Quarto polo / Dördüncü kutup / Четвёртый полюс / 4. biegun / 第 4 极 (与主触头同时动作型)	N — α — N	3KD9105-2	3KD9205-2
⑤	Neutralleiterklemme / Neutral terminal / Borne conducteur neutre / Borne de neutro / Morsetto del conduttore di neutro / Terminal do condutor neutro / Nötr iletken klemensi / Зажим для нулевого провода / Zacisk przewodu neutralnego / 可拆型中性极	N — o — N	3KD9106-2	3KD9206-2
⑥	N-/PE-Klemme / N/PE terminal / Borne N/PE / Borne de N/PE / Morsetto N/PE / Terminal N/PE / N-/PE klemensi / N-/PE Зажим / Zacisk N/PE / 固定型中性极 / 接地端子	N — — — N	3KD9106-8	3KD9206-8
		PE — (⊥)		
⑦	Hilfsschaltermodul / Auxiliary switch module / Bloc de contacts auxiliaires / Módulo de contactos aux. / Modulo blocchetto di contatti ausiliari / Módulo de interruptor auxiliar / Yardımcı şalter modülü / Модуль выключателя вспомогательных цепей / Moduł łącznika pomocniczego / 辅助开关模块	7a	3KD9103-5	
		7b	3KD9103-6	
		7c	3KD9103-7	
⑧	Hilfsschalter / Auxiliary switch / Interrupteur auxiliaire / Bloc de contacts auxiliaires / Blocchetto di contatti ausiliari / Interruptor auxiliar / Yardımcı şalter / Выключатель вспомогательных цепей / łącznik pomocniczy / 辅助开关		3KD9103-1 3KD9103-3	

⑤	Seitliches Hilfsschalter-Modul, in 3KD...4-2N..., 3KD...4-2M... enthalten / Side auxiliary switch module, included in 3KD...4-2N..., 3KD...4-2M... / Bloc de contacts auxiliaires latéral, inclus dans 3KD...4-0N... / Módulo de contactos aux. lateral, incluido en 3KD...4-0N... / Modulo di contatti ausiliari laterale, compreso in 3KD...4-0N... / Módulo de interruptor auxiliar lateral, incluido no 3KD...4-0N... / Yan yardımcı şalter modülü, 3KD...4-0N...'de mevcuttur. / Боковой модуль вспомогательного выключателя, входит в состав 3KD...4-0N... / Boczny moduł przełącznika pomocniczego, zawarty w 3KD...4-0N... / 侧面辅助开关模块, 包含于 3KD...4-2N..., 3KD...4-2M... 中		3KD...4-2N... 3KD...4-2M...
---	---	--	--------------------------------

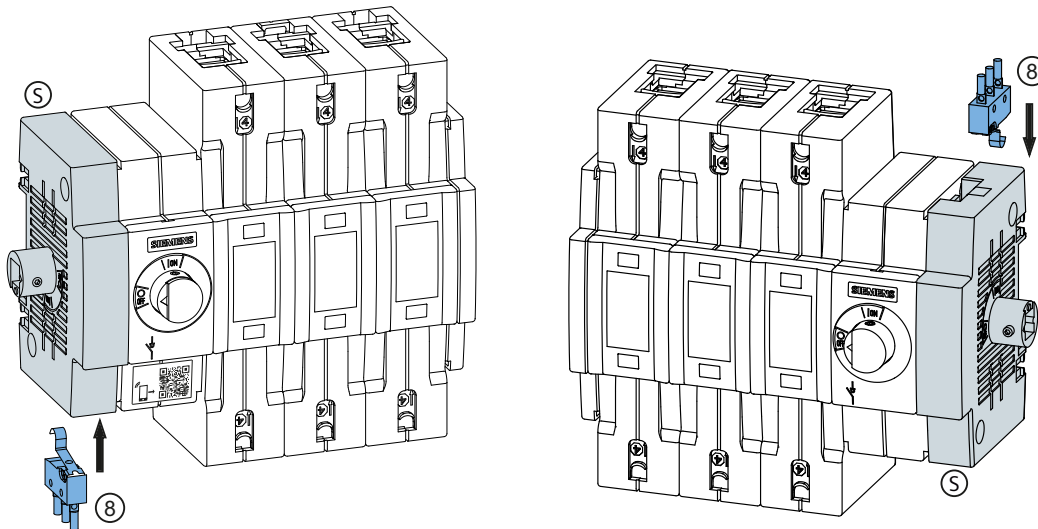

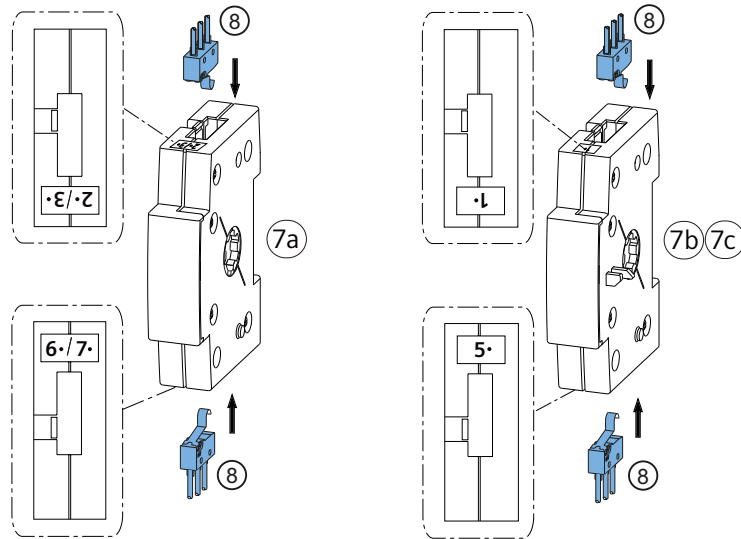

DE	Mögliche Bestückposition	IT	Posizioni di equipaggiamento possibili	PL	Możliwe pozycje wyposażenia
EN	Possible equipment items	PT	Possíveis posições de equipamento	中文	可能的装配位置
FR	Positions d'équipement possibles	TR	Mümkün olan donatım pozisyonları		
ES	Posibles posiciones de equipamiento	PY	Возможные монтажные позиции		

3P

4P

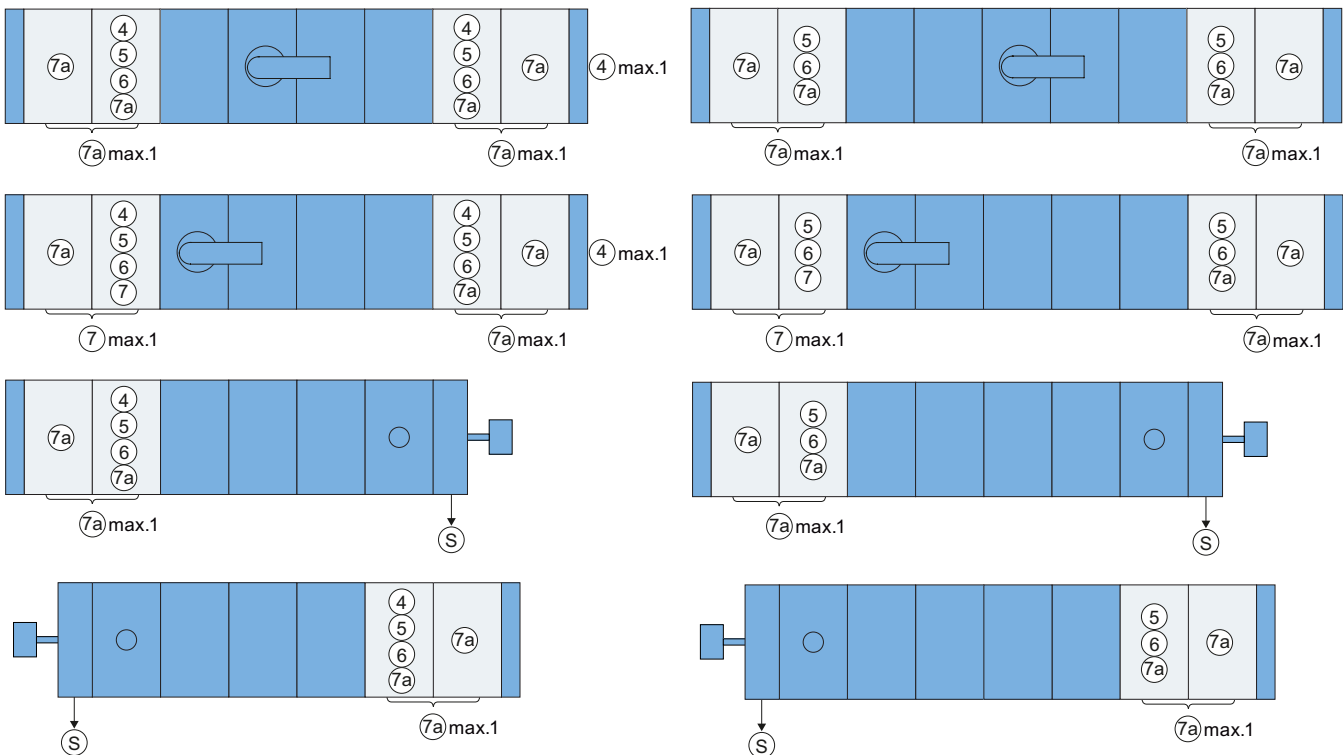

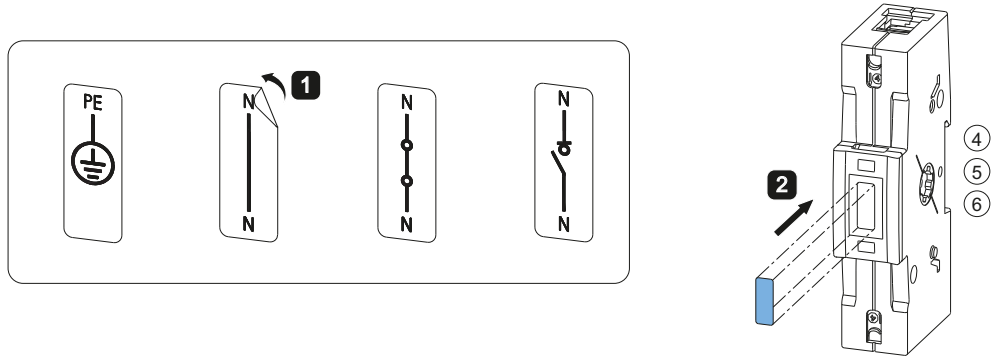
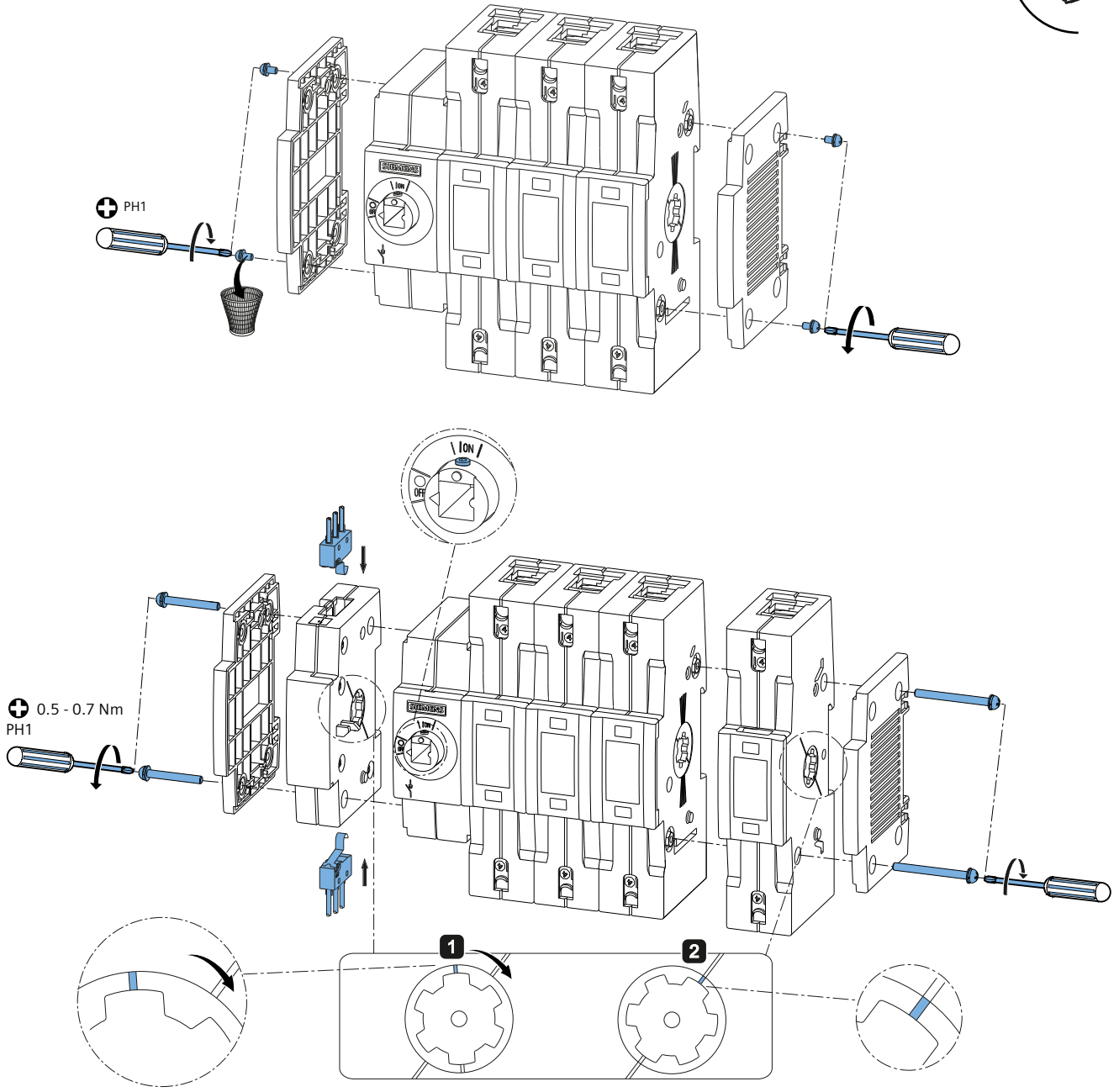

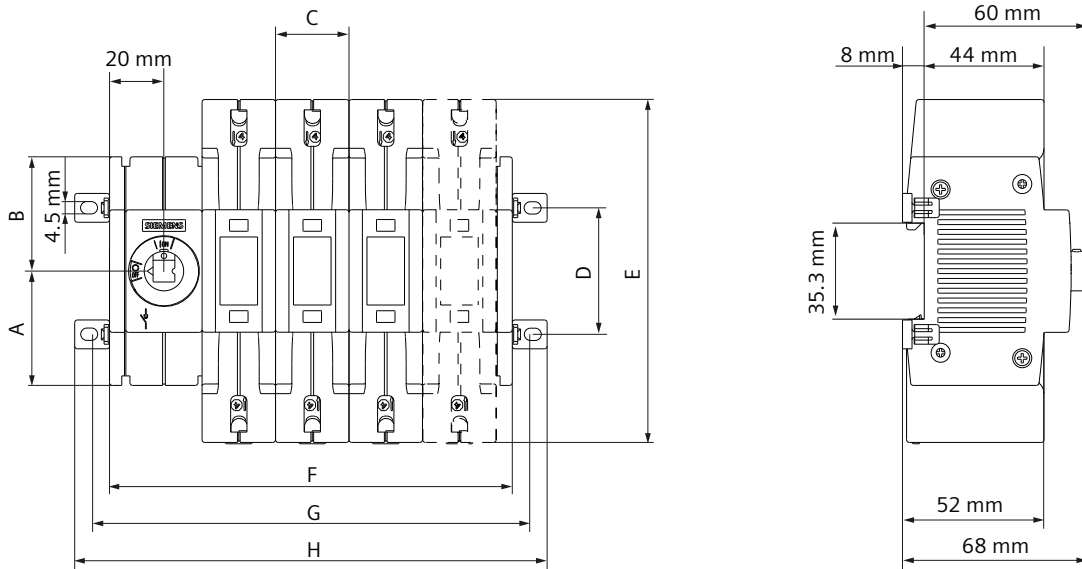

		A [mm]	B [mm]	C [mm]	D [mm]	E [mm]	F [mm]	G [mm]	H [mm]
3KD16 / 22 / 26	3p	42	42	18	46.5	119	94	109	119.6
	4p	42	42	18	46.5	119	112	127	137.6
3KD28 / 30 / 32 / 34 / 36	3p	42	42	27	46.5	126	121	136	146.6
	4p	42	42	27	46.5	126	148	163	173.6

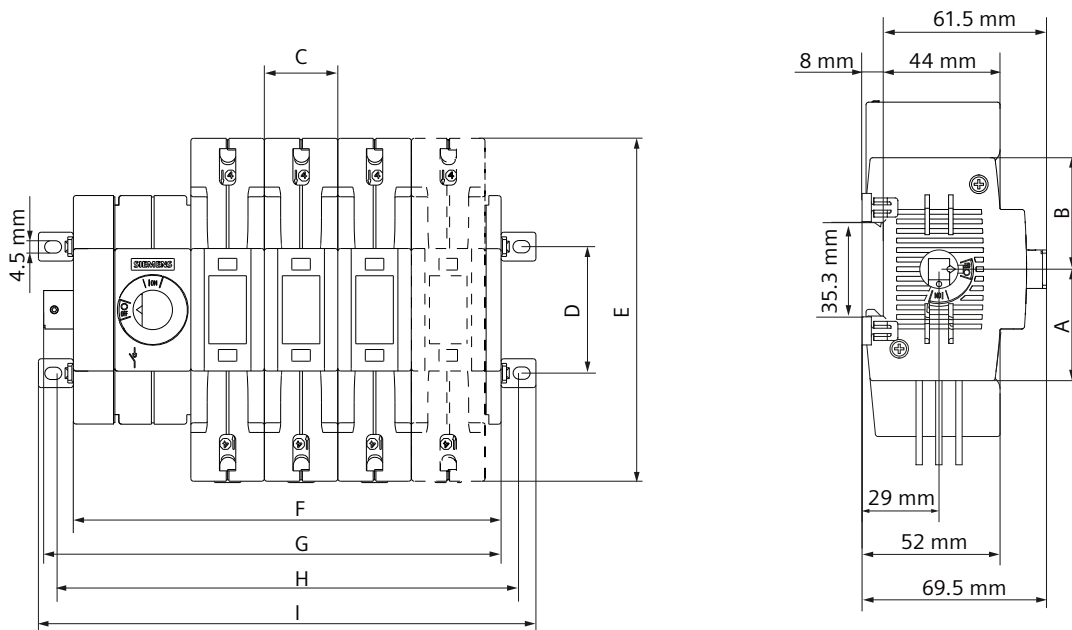

		A [mm]	B [mm]	C [mm]	D [mm]	E [mm]	F [mm]	G [mm]	H [mm]	I [mm]
3KD16 / 22 / 26	3p	42	42	18	46.5	119	103.3	114.3	118.3	128.9
	4p	42	42	18	46.5	119	121.3	132.3	136.3	146.9
3KD28 / 30 / 32 / 34 / 36	3p	42	42	27	46.5	126	130.3	141.3	145.3	155.9
	4p	42	42	27	46.5	126	157.3	168.3	172.3	182.9

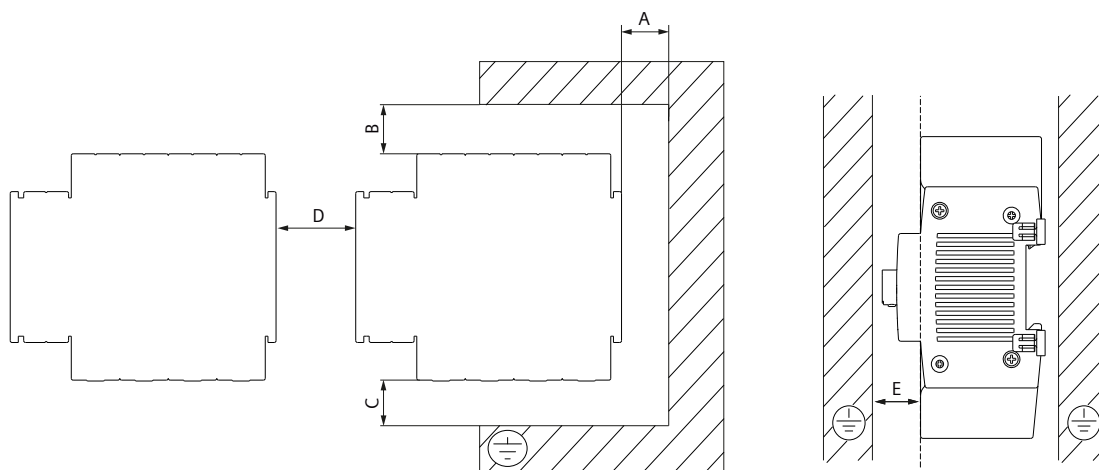
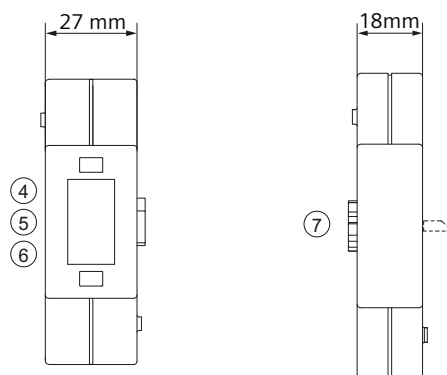

	A [mm]	B [mm]	C [mm]	D [mm]	E [mm]
3KD16 / 22 / 26	0	10		0	
3KD28 / 30 / 32 / 34 / 36	0	10		0	