

Einschubeinheit, Umrüstbausatz für MCCB

Draw-out unit, Conversion kit for MCCB

Unité débrochable, kit de transformation pour disjoncteur boîtier moulé

Unidad extraíble, kit de conversión para interr. caja moldeada

Unità estraibile, kit di adattamento per MCCB

Unidade de inserção, conjunto de conversão para MCCB

Modül ünitesi, MCCB için dönüştürme seti

Выдвижной блок, комплект для переоборудования MCCB

Człon wsuwany, zestaw adaptacyjny do MCCB

卡入式结构单元, 用于 MCCB 的改装套件

3VA912. - 0KD10

3VA921. - 0KD10

3VA932. - 0KD10



IEC 60947

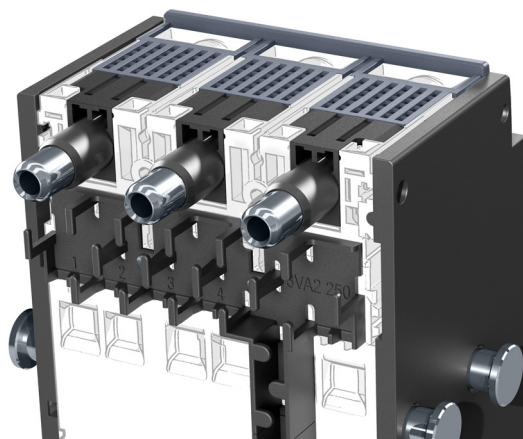

Betriebsanleitung

Operating Instructions

Instructions de service

Instructivo

Istruzioni operative

Instruções de Serviço

İşletme kılavuzu

Руководство по эксплуатации

Instrukcja obsługi

使用说明

DE	GEFAHR	Gefährliche Spannung. Lebensgefahr oder schwere Verletzungsgefahr. Vor Beginn der Arbeiten Anlage und Gerät spannungsfrei schalten.
EN	DANGER	Hazardous voltage. Will cause death or serious injury. Turn off and lock out all power supplying this device before working on this device.
FR	DANGER	Tension électrique. Danger de mort ou risque de blessures graves. Mettre hors tension avant d'intervenir sur l'appareil.
ES	PELIGRO	Tensión peligrosa. Puede causar la muerte o lesiones graves. Desconectar la alimentación eléctrica antes de trabajar en el equipo.
IT	PERICOLO	Tensione pericolosa. Può provocare morte o lesioni gravi. Scollegare l'alimentazione prima di eseguire interventi sull'apparecchiatura.
PT	PERIGO	Tensão perigosa. Perigo de morte ou ferimentos graves. Desligue a alimentação elétrica e proteja contra o religamento, antes de iniciar o trabalho no equipamento.
TR	TEHLİKE	Tehlikeli gerilim. Ölüm tehlikesi veya ağır yaralanma tehlikesi. Çalışmalara başlamadan önce, sistemin ve cihazın gerilim beslemesini kapatınız.
PY	OPACHO	Opasne naprężenie. Opasność dla życia lub możliwość ciężkich травм. Przed rozpoczęciem prac odłączyć podażę energii do instalacji i urządzenia.
PL	ZAGROŻENIE	Niebezpieczne napięcie. Niebezpieczeństwo poważnych obrażeń lub utraty życia. Przed rozpoczęciem prac wyłączyć zasilanie instalacji i urządzenia energią elektryczną.
中文	危险	危险电压。可能导致生命危险或重伤危险。 操作设备时必须确保切断电源。

Technical Support:

Internet: <http://www.siemens.com/lowvoltage/technical-support>



Notwendige Werkzeuge / Necessary tools / Outils nécessaires / Herramientas requeridas / 必要工具

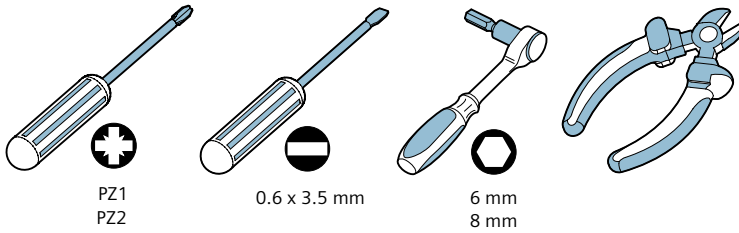

cal. ISO 6789



Lieferumfang / Scope of delivery / Etendue de la livraison / Alcance de suministro / 供货范围





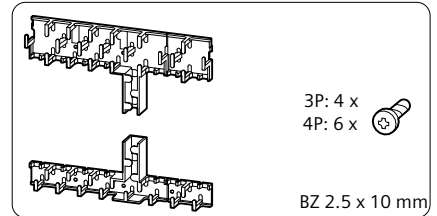
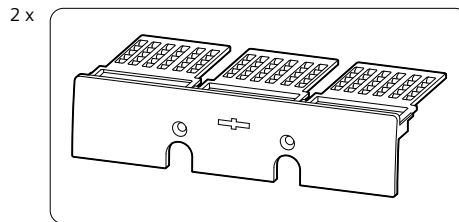
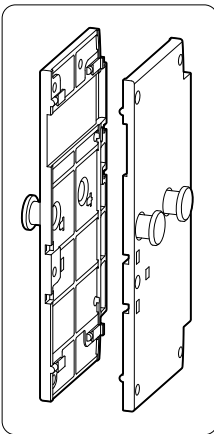
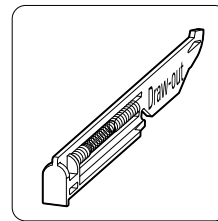

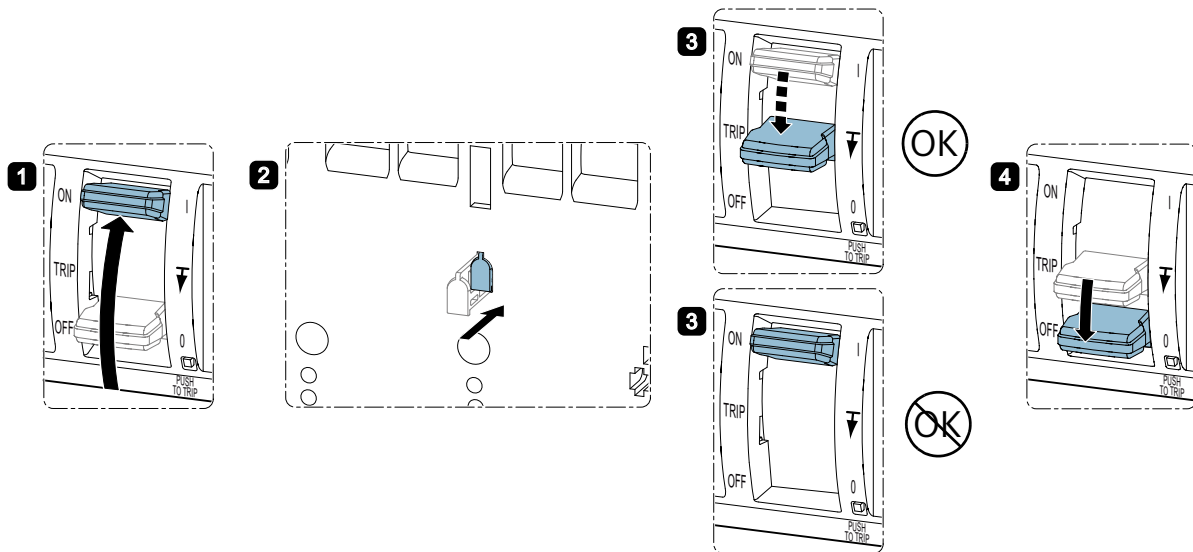
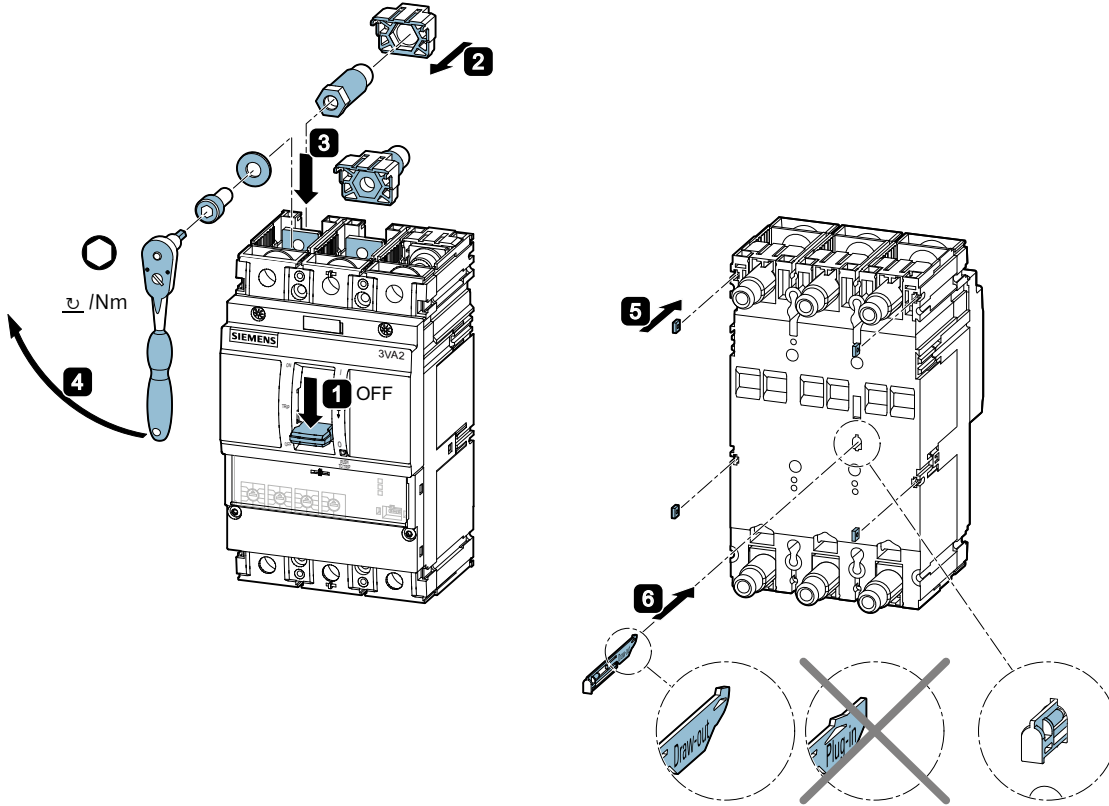

		3P	4P
3VA1	250	3VA9213 - OKD10	3VA9214 - OKD10
3VA2	100 / 160 / 250	3VA9123 - OKD10	3VA9124 - OKD10
	400 / 630	3VA9323 - OKD10	3VA9324 - OKD10

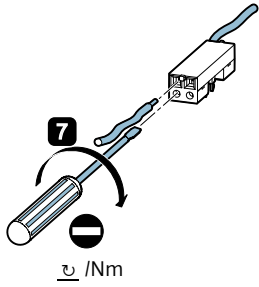

		$\underline{\quad}$ /Nm	mm	$\underline{\quad}$ /Nm		$\underline{\quad}$ /Nm		
		3P: 4x 4P: 4x	3P: 6x 4P: 8x	3P: 4x 4P: 4x				
3VA1	250	M3 x 8 mm	0.5 ... 1.0	M8 x 20 mm	6	20 ... 22	BZ 3.0 x 16 mm	0.6 ... 0.7
3VA2	100 / 160 / 250	M4 x 8 mm	1.0 ... 1.4	M10 x 25 mm	8		BZ 4.0 x 16 mm	0.6 ... 0.8
	400 / 630							

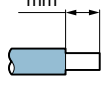



	 mm ²	 /Nm	 mm
	1 x (0.5 ... 1.5)	0.4 ... 0.5	10
	1 x (0.5 ... 1.0)		
 	1 x (1.5 ... 2.5)		

