



I/O module, SmartWire-DT, 24 V DC, 4AI configurable Pt100/Pt1000/Ni1000



Part no. **EU5E-SWD-4PT**
Article no. **144064**

Delivery program

Product range			SmartWire-DT slave
Basic function			Analog modules
Function			For connection of analog I/O signals
Short Description			Configurable inputs: PT100, PT1000, Ni1000
Inputs			
Analog			4
Connection to SmartWire-DT			yes

Technical data

General

Standards			IEC/EN 61131-2
Dimensions (W x H x D)		mm	35 x 90 x 101
Weight		kg	0.1
Mounting			Top-hat rail IEC/EN 60715, 35 mm
Mounting position			As required

Climatic environmental conditions

Climatic proofing			Dry heat to IEC 60068-2-2 Damp heat as per EN 60068-2-3
Air pressure (operation)		hPa	795 - 1080
Ambient temperature			
Operation	θ	°C	-25 - +55
Storage / Transport	θ	°C	-40 - +70
Relative humidity			
Condensation			Take appropriate measures to prevent condensation
Relative humidity, non-condensing (IEC/EN 60068-2-30)		%	5 - 95

Ambient conditions, mechanical

Protection type (IEC/EN 60529, EN50178, VBG 4)			IP20
Vibrations (IEC/EN 61131-2:2008)			
Constant amplitude 3,5 mm		Hz	5 - 8.4
Constant acceleration 1 g		Hz	8.4 - 150
Mechanical shock resistance (IEC/EN 60068-2-27) semi-sinusoidal 15 g/11 ms		Impacts	9
Drop to IEC/EN 60068-2-31	Drop height	mm	50
Free fall, packaged (IEC/EN 60068-2-32)		m	0.3

Electromagnetic compatibility (EMC)

Overvoltage category			II
Pollution degree			2
Electrostatic discharge (IEC/EN 61131-2:2008)			
Air discharge (Level 3)		kV	8
Contact discharge (Level 2)		kV	4
Electromagnetic fields (IEC/EN 61131-2:2008)			
80 - 1000 MHz		V/m	10
1.4 - 2 GHz		V/m	3
2 - 2.7 GHz		V/m	1
Radio interference suppression (SmartWire-DT)			EN 55011 Class B
Burst (IEC/EN 61131-2:2008, Level 3)			
Supply cable		kV	2

Signal lines		kV	2
SmartWire-DT cables		kV	2
Surge (IEC/EN 61131-2:2008, Level 1)			
Surge power cables		kV	1
Surge I/O cables		kV	1
Radiated RFI (IEC/EN 61131-2:2008, Level 3)		V	10

SmartWire-DT network

Station type			SmartWire-DT slave
Setting the baud rate			automatic
Baud rate (data transfer speed)		kbps	maximum 250
Status SmartWire-DT		LED	Green
Connection			Plug, 8-pole Connection plug: external device plug SWD4-8SF2-5
Current consumption	I_e	mA	22

Connection supply and I/O

Terminal for I/O sensor			
Connection type			Push in terminals
Solid		mm ²	0.2 - 1.5 (AWG 24 - 16)
Flexible with ferrule		mm ²	0.25 - 1.5 (AWG 24 - 16)
			Minimum length 8 mm

24 V DC supply for output supply

Power supply			
Rated operational voltage	U_e	V	24 DC -15 % / +20 %
Residual ripple on the input voltage		%	 5
Protection against polarity reversal			Yes
Power loss	P	W	0.6

Temperature inputs

Quantity			4 (2, 3-wire connection, screened, length < 10 m)
Parameter setting			
Averaging			einstellbar
Temperature sensor			PT100, PT1000, Ni1000
Temperature range		°C	PT100, PT1000: -50 - +200 Ni1000: -50 - +150
Resolution		°C	0.1
Conversion time		ms	250
Display			°C, °F, raw value
Total error		%	± 1
Repetition accuracy		%	± 0.5

Potential isolation

Inputs for SmartWire-DT			Yes
Input to input			No

Design verification as per IEC/EN 61439

Technical data for design verification			
Rated operational current for specified heat dissipation	I_n	A	0
Heat dissipation per pole, current-dependent	P_{vid}	W	0
Equipment heat dissipation, current-dependent	P_{vid}	W	0
Static heat dissipation, non-current-dependent	P_{vs}	W	0.6
Heat dissipation capacity	P_{diss}	W	0
Operating ambient temperature min.		°C	-25
Operating ambient temperature max.		°C	55
Degree of Protection			IP20
IEC/EN 61439 design verification			
10.2 Strength of materials and parts			
10.2.2 Corrosion resistance			
			Meets the product standard's requirements.

10.2.3.1 Verification of thermal stability of enclosures		Meets the product standard's requirements.
10.2.3.2 Verification of resistance of insulating materials to normal heat		Meets the product standard's requirements.
10.2.3.3 Verification of resistance of insulating materials to abnormal heat and fire due to internal electric effects		Meets the product standard's requirements.
10.2.4 Resistance to ultra-violet (UV) radiation		Meets the product standard's requirements.
10.2.5 Lifting		Does not apply, since the entire switchgear needs to be evaluated.
10.2.6 Mechanical impact		Does not apply, since the entire switchgear needs to be evaluated.
10.2.7 Inscriptions		Meets the product standard's requirements.
10.3 Degree of protection of ASSEMBLIES		Meets the product standard's requirements.
10.4 Clearances and creepage distances		Meets the product standard's requirements.
10.5 Protection against electric shock		Does not apply, since the entire switchgear needs to be evaluated.
10.6 Incorporation of switching devices and components		Does not apply, since the entire switchgear needs to be evaluated.
10.7 Internal electrical circuits and connections		Is the panel builder's responsibility.
10.8 Connections for external conductors		Is the panel builder's responsibility.
10.9 Insulation properties		
10.9.2 Power-frequency electric strength		Is the panel builder's responsibility.
10.9.3 Impulse withstand voltage		Is the panel builder's responsibility.
10.9.4 Testing of enclosures made of insulating material		Is the panel builder's responsibility.
10.10 Temperature rise		The panel builder is responsible for the temperature rise calculation. Eaton will provide heat dissipation data for the devices.
10.11 Short-circuit rating		Is the panel builder's responsibility.
10.12 Electromagnetic compatibility		Is the panel builder's responsibility.
10.13 Mechanical function		The device meets the requirements, provided the information in the instruction leaflet (IL) is observed.

Technical data ETIM 6.0

PLC's (EG000024) / Fieldbus, decentr. periphery - analogue I/O module (EC001596)		
Electric engineering, automation, process control engineering / Control / Field bus, decentralized peripheral / Field bus, decentralized peripheral - analogue I/O module (ecl@ss8.1-27-24-26-01 [BAA061011])		
Supply voltage AC 50 Hz	V	0 - 0
Supply voltage AC 60 Hz	V	0 - 0
Supply voltage DC	V	0 - 0
Voltage type of supply voltage		DC
Input, current		No
Input, voltage		No
Input, resistor		No
Input, resistance thermometer		Yes
Input, thermocouple		No
Input signal, configurable		No
Resolution of the analogue inputs	Bit	12
Output, current		No
Output, voltage		No
Output signal configurable		No
Resolution of the analogue outputs	Bit	0
Number of analogue inputs		4
Number of analogue outputs		0
Analog inputs configurable		Yes
Analog outputs configurable		Yes
Number of HW-interfaces industrial Ethernet		0
Number of HW-interfaces PROFINET		0
Number of HW-interfaces RS-232		0
Number of HW-interfaces RS-422		0
Number of HW-interfaces RS-485		0
Number of HW-interfaces serial TTY		0
Number of HW-interfaces parallel		0
Number of HW-interfaces Wireless		0
Number of HW-interfaces other		0

Supporting protocol for TCP/IP		No
Supporting protocol for PROFIBUS		No
Supporting protocol for CAN		No
Supporting protocol for INTERBUS		No
Supporting protocol for ASI		No
Supporting protocol for KNX		No
Supporting protocol for MODBUS		No
Supporting protocol for Data-Highway		No
Supporting protocol for DeviceNet		No
Supporting protocol for SUCONET		No
Supporting protocol for LON		No
Supporting protocol for PROFINET IO		No
Supporting protocol for PROFINET CBA		No
Supporting protocol for SERCOS		No
Supporting protocol for Foundation Fieldbus		No
Supporting protocol for EtherNet/IP		No
Supporting protocol for AS-Interface Safety at Work		No
Supporting protocol for DeviceNet Safety		No
Supporting protocol for INTERBUS-Safety		No
Supporting protocol for PROFIsafe		No
Supporting protocol for SafetyBUS p		No
Supporting protocol for other bus systems		Yes
Radio standard Bluetooth		No
Radio standard WLAN 802.11		No
Radio standard GPRS		No
Radio standard GSM		No
Radio standard UMTS		No
IO link master		No
System accessory		Yes
Degree of protection (IP)		IP20
Type of electric connection		Flat plug-in connection
Fieldbus connection over separate bus coupler possible		Yes
Rail mounting possible		Yes
Wall mounting/direct mounting		Yes
Front build in possible		No
Rack-assembly possible		No
Suitable for safety functions		No
Category according to EN 954-1		
SIL according to IEC 61508		None
Performance level acc. to EN ISO 13849-1		None
Appendant operation agent (Ex ia)		No
Appendant operation agent (Ex ib)		No
Explosion safety category for gas		None
Explosion safety category for dust		None
Width	mm	35
Height	mm	90
Depth	mm	97

Approvals

UL File No.		E29184
UL Category Control No.		NKCR
CSA File No.		2324643
CSA Class No.		3211-07
North America Certification		UL listed, CSA certified
Specially designed for North America		No

Dimensions

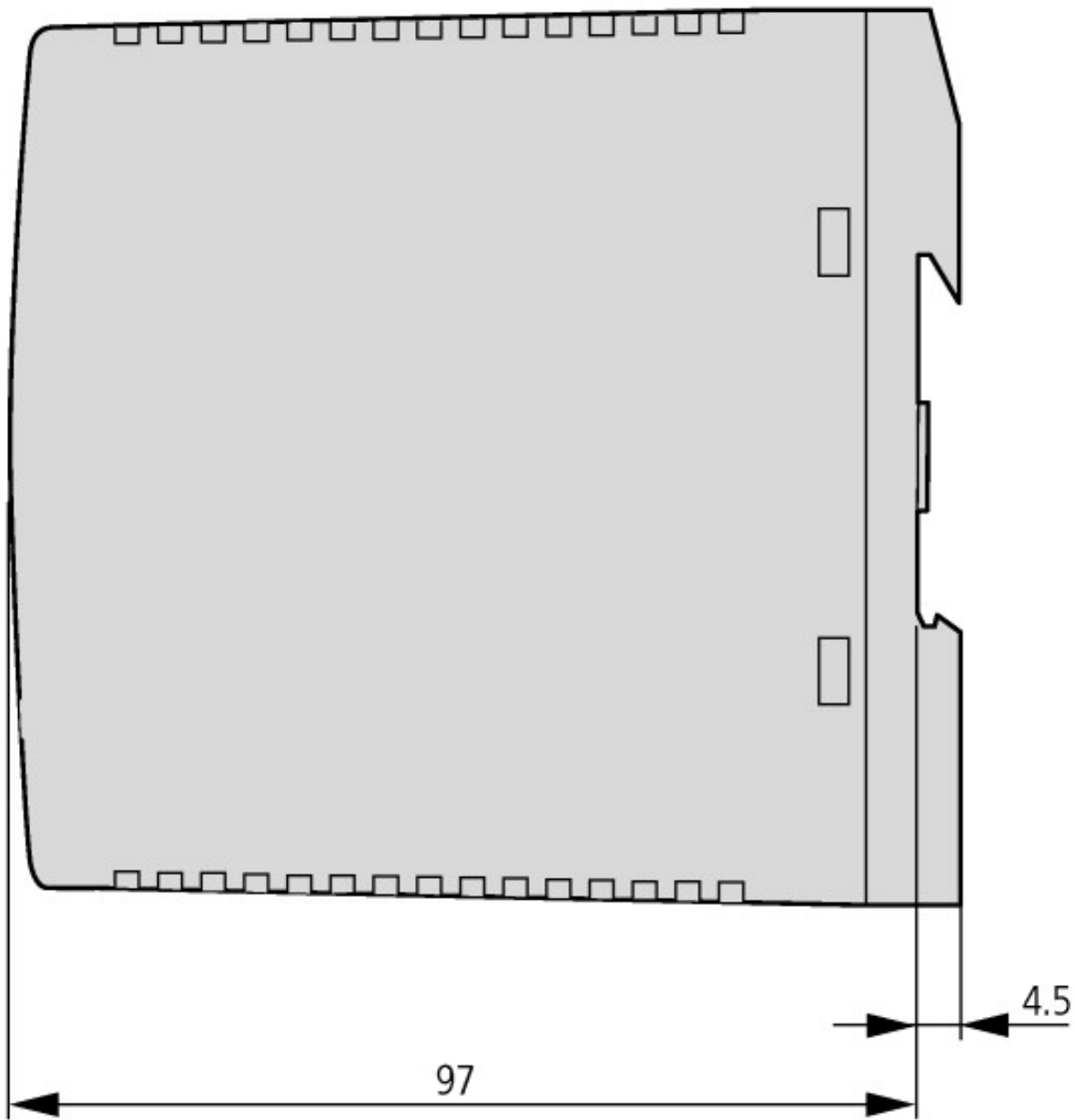

SmartWire-DT I/O modules (IP20)

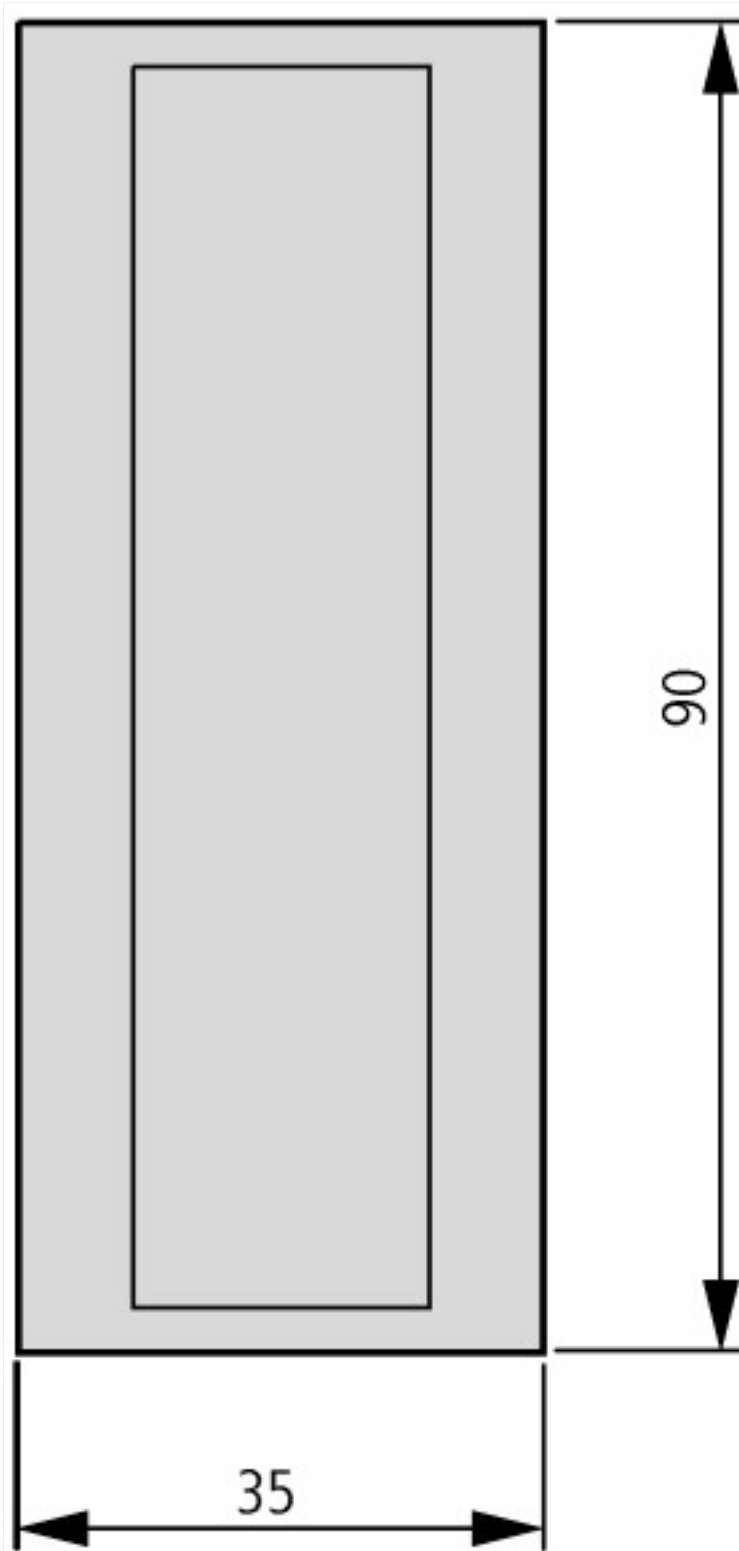

Additional product information (links)

Instruction leaflet "SWD I/O modules EU5E-SWD..." IL05006002Z

Instruction leaflet "SWD I/O modules EU5E-SWD..." IL05006002Z ftp://ftp.moeller.net/DOCUMENTATION/AWA_INSTRUCTIONS/IL05006002Z2015_12.pdf

MN05006001Z (AWB2723-1613) SWD modules

MN05006001Z (AWB2723-1613) SWD-Teilnehmer - Deutsch ftp://ftp.moeller.net/DOCUMENTATION/AWB_MANUALS/MN05006001Z_DE.pdf

MN05006001Z (AWB2723-1613) SWD modules - English ftp://ftp.moeller.net/DOCUMENTATION/AWB_MANUALS/MN05006001Z_EN.pdf

MN05006001Z (AWB2723-1613) udente SWD - italiano ftp://ftp.moeller.net/DOCUMENTATION/AWB_MANUALS/MN05006001Z_IT.pdf

MN05006002Z (AWB2723-1617) SmartWire-DT, The system

MN05006002Z (AWB2723-1617) SmartWire-DT, Das System - Deutsch ftp://ftp.moeller.net/DOCUMENTATION/AWB_MANUALS/MN05006002Z_DE.pdf

MN05006002Z (AWB2723-1617) SmartWire-DT, The system - English ftp://ftp.moeller.net/DOCUMENTATION/AWB_MANUALS/MN05006002Z_EN.pdf

MN05006002Z (AWB2723-1617) SmartWire-DT, il sistema - italiano	ftp://ftp.moeller.net/DOCUMENTATION/AWB_MANUALS/MN05006002Z_IT.pdf
http://ecat.moeller.net/flip-cat?edition=SWCAT&startpage=Title;Product Range Catalog SmartWire-DT	
Technical data	http://ecat.moeller.net/flip-cat?edition=SWCAT&startpage=32
SWD-ASSIST	http://downloadcenter.moeller.net/en/software.a487d8b7-da91-486f-b3ba-a7ca2035db99