



**Illuminated pushbutton actuators, Flat Front, flush, momentary, white, labeled**

**Part no. M30C-FDL-W-X100**  
**Catalog No. 182966**  
**Eaton Catalog No. M30C-FDL-W-X100**

**Technical data**

**General**

Standards			IEC/EN 60947 VDE 0660
Lifespan, mechanical	Operations	x 10 <sup>6</sup>	> 5
Operating frequency	Operations/h		≤ 3600
Actuating force		n	≤ 5
Climatic proofing			Damp heat, constant, to IEC 60068-2-78 Damp heat, cyclic, to IEC 60068-2-30
Degree of Protection			IP66, IP67, IP69
Ambient temperature			
Open		°C	-25 - +70
Mounting position			As required
Mechanical shock resistance		g	15 Shock duration 11 ms Sinusoidal according to IEC 60068-2-27

**Design verification as per IEC/EN 61439**

Technical data for design verification			
Operating ambient temperature max.		°C	-25
Operating ambient temperature max.		°C	70

**Technical data ETIM 6.0**

Low-voltage industrial components (EG000017) / Front element for push button (EC000221)			
Electric engineering, automation, process control engineering / Low-voltage switch technology / Command and alarm device / Front element for push-button actuators (ecl@ss8.1-27-37-12-10 [AKF028011])			
Colour button			White
Number of command positions			1
Construction type lens			Round
Hole diameter		mm	30
Width opening		mm	0
Height meter opening		mm	0
Degree of protection (IP), front side			IP67
Type of button			Flat
Suitable for illumination			Yes
With protection cover			No
Labelled			Yes
Switching function latching			No
Spring-return			Yes
With front ring			Yes
Material front ring			Metal
Colour front ring			Chrome

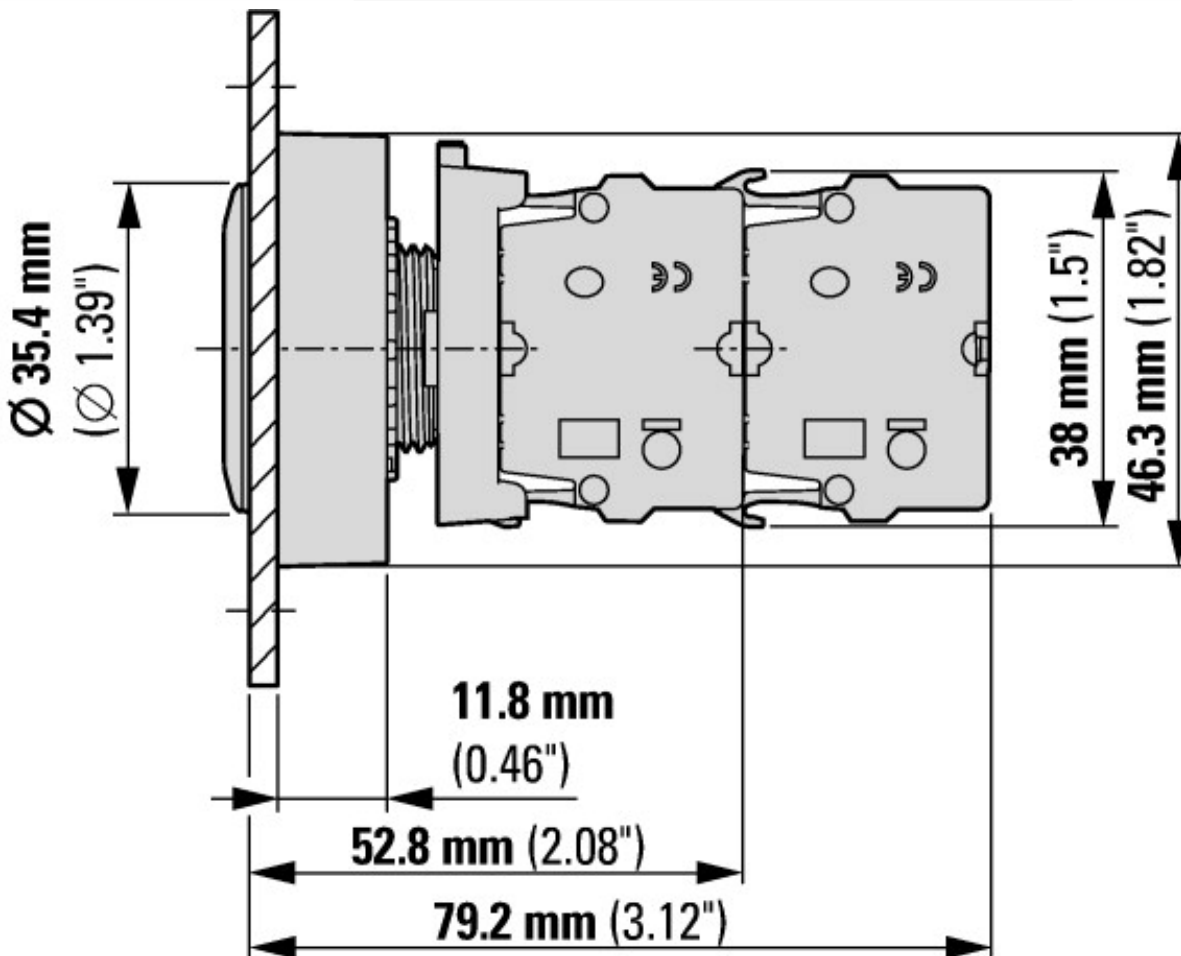
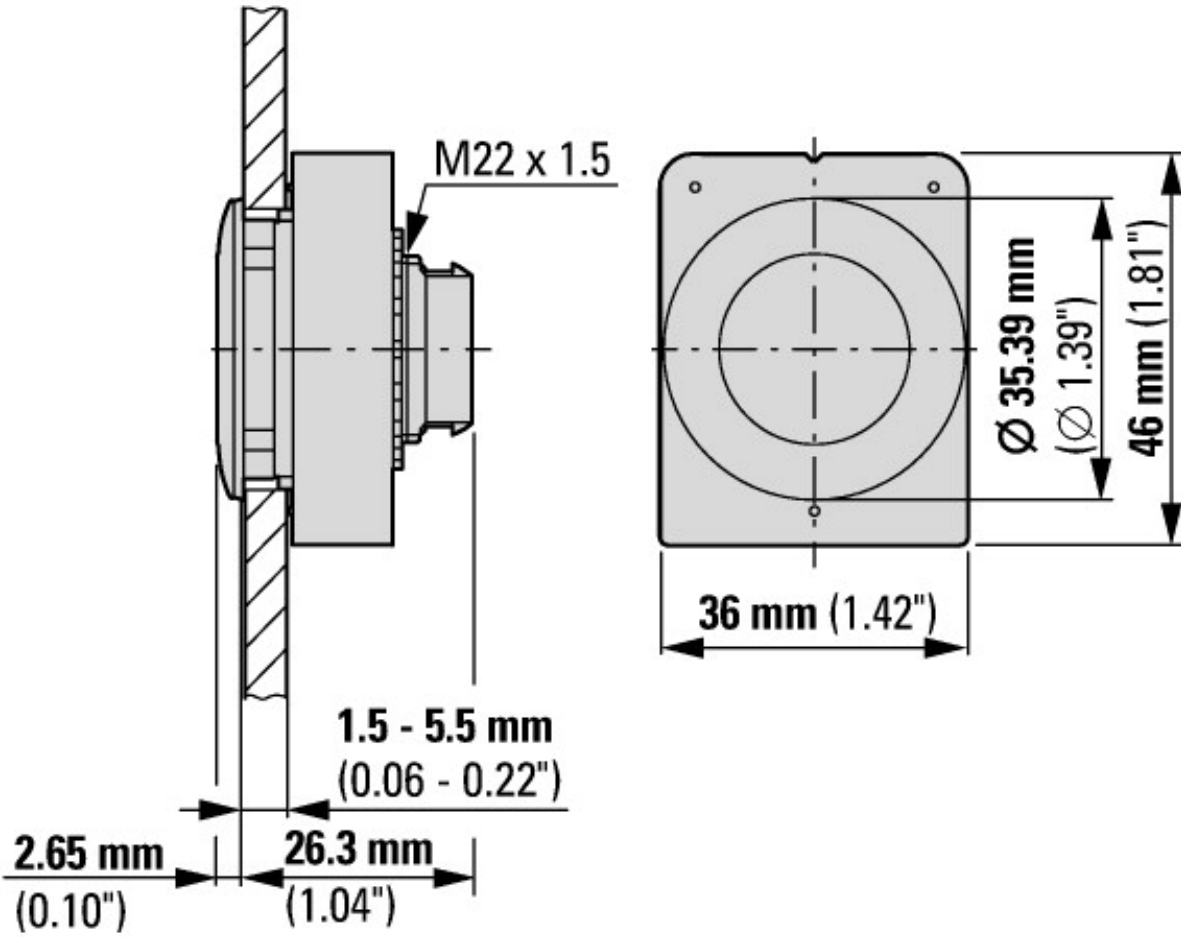

with 2 M22-K... standard contact elements

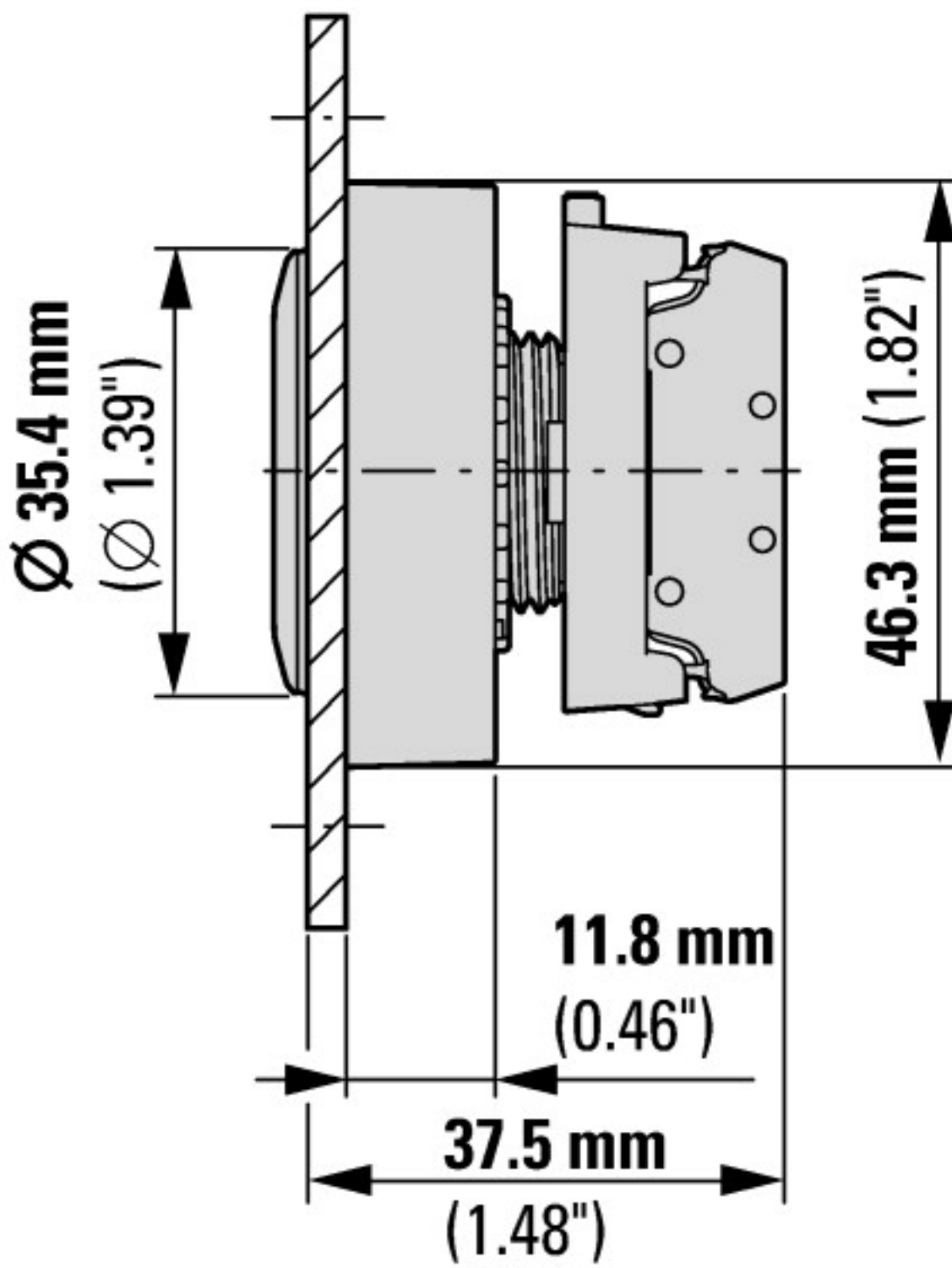

with M22-FK... flat rear contact elements

