

DALI CS



Datasheet **Combi Sensor Module**

Sensor unit for automatic lighting
control in DALI systems

Art. Nr. 86458621 (DALI CS Temp)

DALI CS Combi Sensor Module

Overview

- Sensor Module for DALI lighting systems
- Motion detection
- Light intensity measurement
- motion dependent control
- automatic lighting control (firmware 4.13 and higher)
- Sensor for ambient temperature measurement and monitoring
- on request: integrated IR remote control receiver
- The DALI CS module can be used either as active lighting control unit or for measurements and monitoring only
- Sensor properties are set easily via the “DALI-Cockpit” software tool
- The DALI CS is able to transmit DALI-commands (e.g. ON, OFF, RECALL MIN/MAX, GO TO SCENE X, ...) to single destination addresses, group addresses or broadcast.
- The rotary switch on the back of the housing helps to assign a destination group address easily
- Several DALI CS modules can be used within one DALI-line
- The compact module can easily be installed in recessed conduit boxes or directly on cavity walls.
- The DALI CS must not be connected to the mains. It is directly supplied by the DALI-line.

Specification, Characteristics

Type	DALI CS Temp
article number	86458621
power supply	via DALI-line
typ. current consumption	3.5 mA
input/ouput	DALI
sensors	motion light intensity temperature
function	adjustable
operating temperature	0°C-70°C
storage temperature	-25°C-85°C
protection class	IP20
connecting wire cross section	0.5-1.5 mm ²
operating temperature	RAL9010

PIR Motion Detection:
 distance: <12m, 92 zones
 range: hor.: ±51°, vert. ±46°
 temp.diff. target to ambience: >4°C

Light Intensity Measurement:
 range: 0-2500lux, resolution: 1lux

Temperature Measurement:
 range: 0°C-70°C, resolution: 1°C

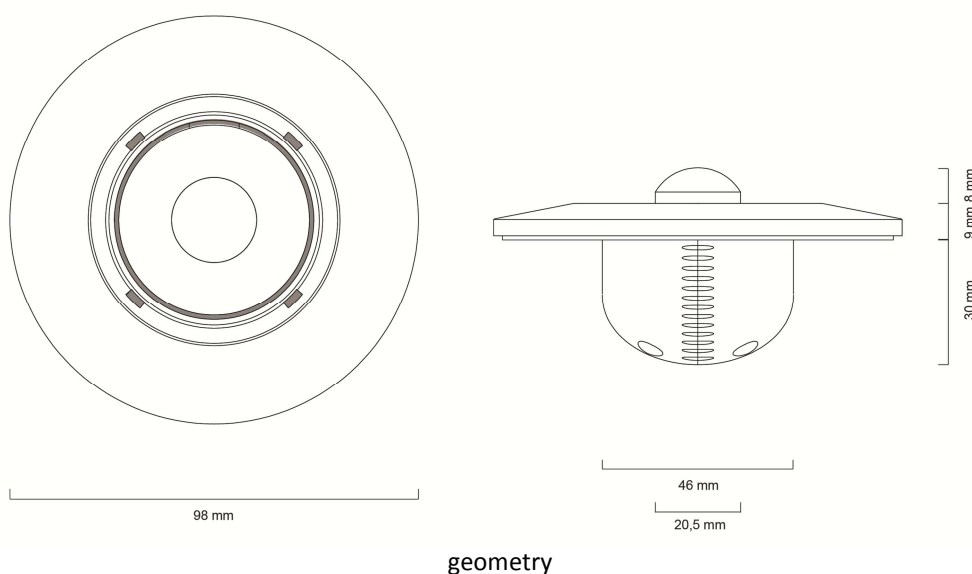
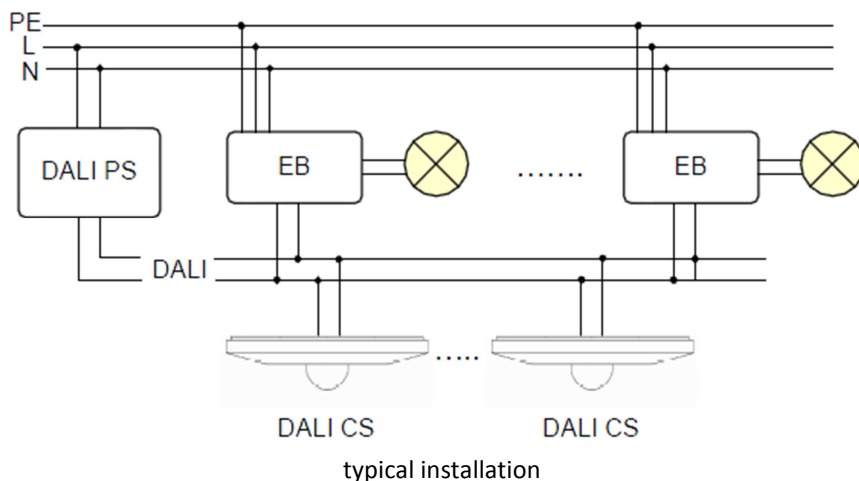

Installation

The DALI CS module is connected to the DALI-line. It is powered directly by the DALI signal line (that is supplied by an adequate bus power supply like the DALI PS). A typical value for the current consumption is 3.5mA.

The DALI-line input is polarity free and protected against overvoltage of up to 270Vac.

Allowed connection wire cross sections range from 0.5mm² to 1.5mm².

The DALI CS mounting ring can be attached to cavity walls directly or by using an electrical box.



rear view / mounting ring

The housing can then simply be attached on the mounting ring. Even in a flush-mounted box there is enough room for a sunken sensor head.



sensor head: sunken and extended

Finally the sensor head can be aligned to the desired position. Declination angles of 40° in vertical and 360° in axial direction are provided.



aligned sensor head

Function and Configuration

The DALI CS measures various physical properties (motion, light intensity and temperature) and offers the possibility to react according to the measurements by sending DALI commands.

Via a DALI-USB interface the software tool “DALI-Cockpit” can communicate with the DALI CS. So the desired function can be configured easily on PC. DALI-Cockpit and DALI-USB interface are required for the

configuration only and can be removed when configuration is finished.

The settings of the sensor components and the configuration of the DALI commands and destination addresses can be defined in the DALI Cockpit. Before going in detail the function of the sensors and the basic operating conditions of the DALI CS will be explained.

Motion Detection

The motion sensor is spatially divided into 92 zones. In each zone the received thermal radiation is determined and differentially compared to the adjacent zones (PIR sensor).

For motion detection there is a need for a temperature difference of at least 4°C between moving object and environment. Heat sources such as copiers or heaters may have a negative influence on motion detection.

This method allows observation of relatively large areas by using only one sensor head. With opening angles of 46.3° and 51.3° and a sensor mounted at a height of 5 meters the 92 zones cover an area of more than 100m².

The distance between sensor and the object of interest should be less than 12 meters.

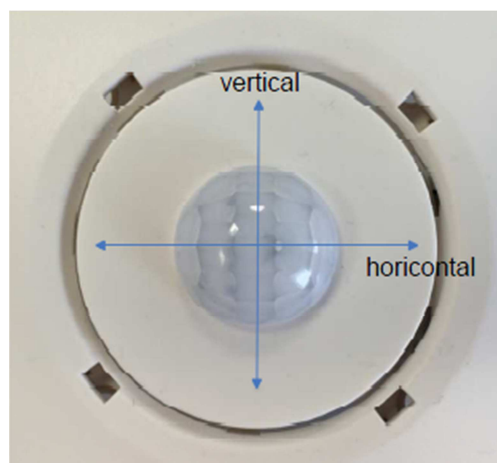

Sensor head vertical (±46°)/horizontal (±51°)

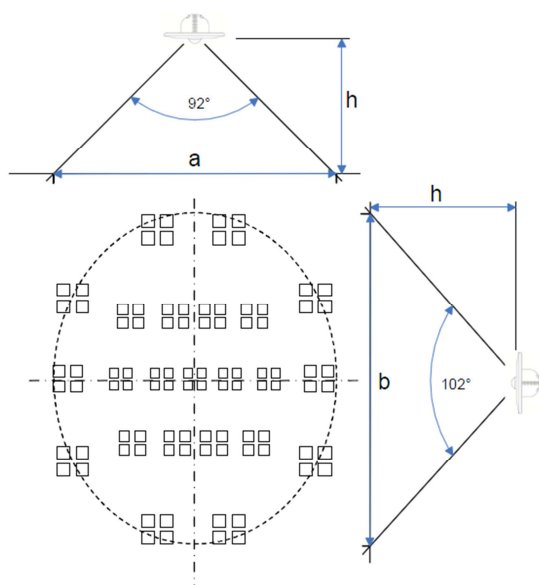

h [m]	a [m]	b [m]	A [m ²]
2,50	5,2	6,2	25,1
2,7	5,6	6,7	29,3
3,0	6,2	7,4	36,2
3,5	7,2	8,6	49,2
4,0	8,3	9,9	64,3
5,0	10,4	12,3	100,4
6,0	12,4	14,8	144,6
8,0	16,6	19,8	257,1
10,0	20,7	24,7	401,7

relation of angle, height and covered detection area

Light Intensity Sensor

The light sensor measures illuminance in a range from 0 to 2500 lux. The resolution is 1 lux.

The incident light is rated by the spectral sensitivity of the human eye and thus a property for the subjective visual perception of brightness.

Temperature Measurement

The temperature sensor covers a range from 0°C to 70°C. The resolution is 1°C.

IR Remote Control Empfänger

On request the DALI CS is available with an integrated IR-remote receiver (instead of the temperature sensor).

Configuration

For applications requiring a motion sensor only the default configuration may be sufficient. The destination address can be set by the rotary switch on the rear side of the sensor (0...Broadcast, 1...15 -> group addresses G0...G14).

In the default configuration light- and temperature-sensor are deactivated. The motion sensor sends the DALI-command RECALL MAX in case of a detected motion and the DALI-command OFF after a delay of 10 minutes if movement isn't detected any longer. The destination address is G0...G14 or broadcast as selected by the rotary switch.

Even several sensors can be used without configuration for the same effective range (e.g. in a corridor), because sensors for the same effective range auto-synchronize themselves.

For any other configuration the free DALI-Cockpit software tool can be used to adjust the sensor individually.

In the DALI-Cockpit the DALI addressing procedure can easily be initiated. After addressing has finished the spatial localization of any DALI CS can be done by forcing the desired sensor to turn on a red LED. Therefore select the check box to switch on the LED in the DALI Cockpit. The relationship between

spatial arrangement and assigned number in the software is simply established that way.

Settings Motion Sensor

The PIR sensor detects motion. Hence on detected movement detection as well as on disappearance of a previously detected motion DALI commands can be defined to be sent on the DALI-line.

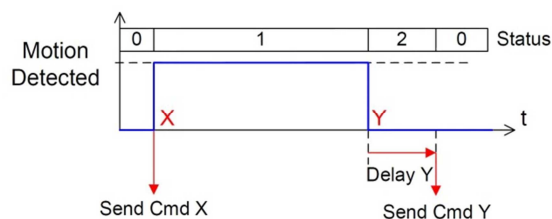

timing motion detection / reaction

In the case of the disappearance of a previously detected motion a delay time between the occurrence of the event and the transmission of the DALI command can be defined.

With these options the light can be switched on and off dependent on motion.

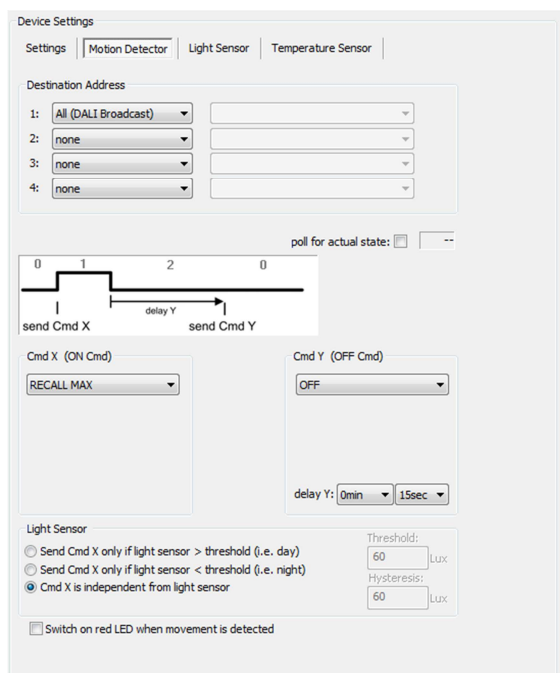

Furthermore the effective range and the dependence on the actual light level (active/inactive over or under a defined threshold (0...1020lux, 4 lux steps)) can be configured, e.g. for different behaviour for day and night.

Settings Light Sensor

Up from firmware version 4.13 the DALI CS offers a control algorithm for automatic brightness control. This method is coupled to the motion sensor. After the motion sensor has detected motion and switched on the light with a user-defined DALI command the automatic brightness control starts and tries to reach the set value of the light intensity. In this operation the effective range of the light sensor is the same like for the motion sensor.

The set value of the light intensity can range from 0...2400 lux in steps of 8lux. Furthermore the auto-adjustment of the set value due to manual dim-commands (UP/DOWN) can be activated or deactivated.

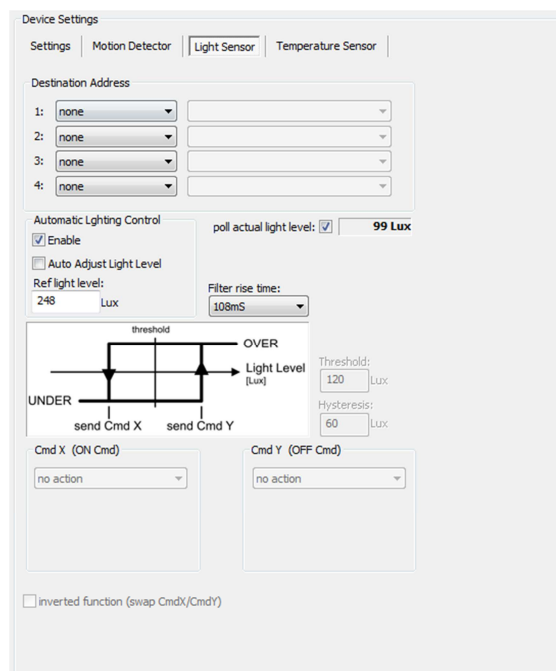

If automatic lighting control is inactive, the effective range can be defined independently from the motion sensor.

Switching thresholds for light intensity can be defined with the help of values for threshold and hysteresis. When the measured value falls below the lower limit or exceeds the upper one various DALI-commands can be selected to be sent as response.

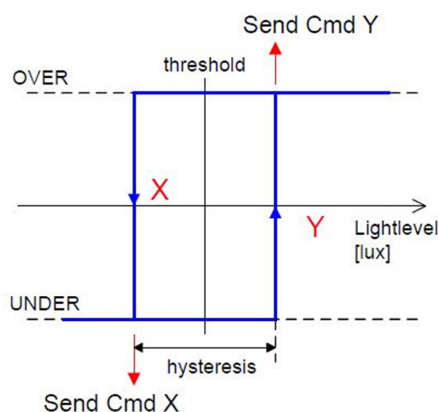

hysteresis light sensor

Settings Temperature Sensor

The setting of switching thresholds is implemented similar to the light sensor. The thresholds can range from -20°C to +70°C (hysteresis 0.1°C to 25.5°C). DALI commands can be defined to be sent to an effective range if the temperature value exceeds the defined thresholds. The effective range is independent from motion sensor and light sensor.

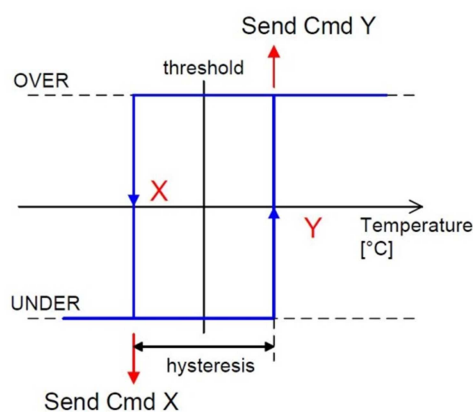

hysteresis temperature sensor

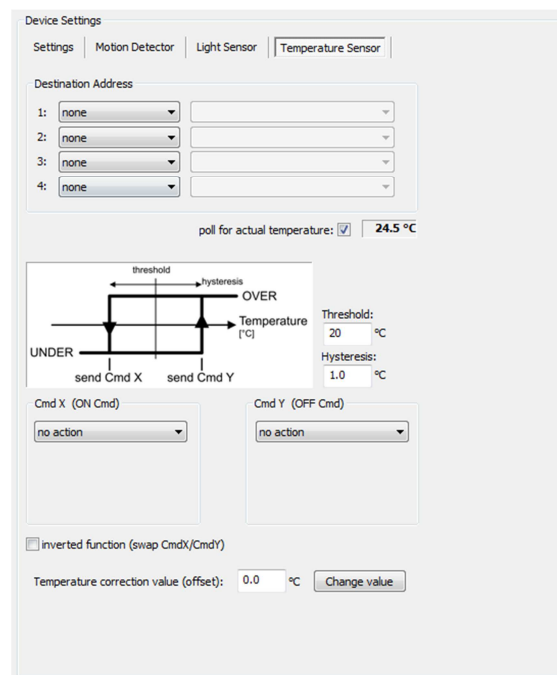

Selectable DALI commands for CmdX/CmdY

For each sensor unit DALI-commands can be used for the event commands CmdX (typically the On-Cmd) and CmdY (typically the Off-Cmd). These commands are sent to the effective range if the corresponding event occurs. Besides the selection below especially for light and temperature hysteresis mode further DALI-commands are available.

CmdX (ON-Cmds):

Cmd number	Cmd name	function
-	DIRECT ARC POWER>0	direct arc power in %
5	RECALL MAX	recalls MAX value
6	RECALL MIN	recalls MIN value
8	ON AND STEP UP	Increases light level by one increment, if OFF switch ON (MIN value)
16-31	GO TO SCENE	go to scene 0-15

CmdY (Off-Cmds):

Cmd number	Cmd name	function
-	DIRECT ARC POWER = 0	direct arc power in %
0	OFF	off
16-31	GO TO SCENE	go to scene 0-15

If direct arc power commands are use as command the fadetime can be set as well.

Operating Behaviour

The DALI CS acts as configured. If motion is detected the DALI CS sends the CmdX as On-Cmd. If manual interaction occurs, the DALI CS reacts as follows:

RECALL MAX, RECALL MIN, ON AND STEP UP, DAP>0%, GOTO SCENE X (if defined as CmdX):

motion sensor deactivated, Light control deactivated

OFF, DAP=0, GOTO SCENE X (if defined as CmdY):

Motion sensor activated (State: Waiting for motion), light control deactivated

GOTO SCENE X (if not defined as CmdX/ CmdY):

no effect

UP/DOWN (if AutoAdjust Light Level enabled):

The set value of the automatic lighting control can be adjusted with the help of UP/DOWN commands sent to the first address of the effective range. The value after the dimming is measured and used as new set value.

Beside the mentioned effect of DALI-commands to the effective range the automatic light control can be activated by proprietary commands as well:

Cmd 218 Store DTR As Auto Light Mode

Cmd 219 Query Auto Light Mode

Auto Light Mode:

0 ... automatic light control disabled

1 ... automatic light control enabled

2 ... automatic light control enabled, auto adjust light level active

Cmd 220 Store DTR as Auto Light Reference

Cmd 221 Query Auto Light Reference

*Auto Light Reference: value * 8lux*

The DALI CS can be used as control device as well as a measurement unit only. In this case we recommend to define no effective ranges and to query the sensor values. A special operating mode is available If each sensor in the unit should act as measurement unit .

Reading Sensor Values and Other Important Commands

The measured values can either be read out with proprietary commands or after having assigned a DALI address to the DALI CS, the values can be read out by querying scene level values.

Proprietary Commands:

Supported Sensors

Cmd215 Query Supported Sensors

bit 0: Motion Sensor supported

bit 1: Light Sensor supported

bit 2: IR sensor supported

bit 3: Temp Sensor supported

Motion Sensor:

Cmd200 Query Motion Status

0 ... no motion detected

1 ... motion detected

2 ... motion has beed detected, delay running

*Cmd101 Motion Sensor OFF-State
sync, from sensor to effective range*

*Cmd102 Motion Sensor ON-State
sync, from sensor to effective range
Lightsensor – Light Level*

*Cmd205 Query Light Level Low
Must be read first*

*Cmd206 Query Light Level High
Light Level = Light Level High * 256 + Light
Level Low*

Temperature:

*Cmd210 Query Temperature
temp = (answer-80)/2 [-40°C ... 87,5°C]*

Query using Scene Levels:

Temperature:

*DALI176 Query Scene 0 Value
Temp High in °C [-128°C bis +127°C]
DALI177 Query Scene 1 Value
Temp Low in 1/256°C*

Temp = Temp High + Temp Low / 256

Light Level:

*DALI 178 Query Scene 2 Value
Light Level High in Lux, must be read first
DALI 179 Query Scene 3 Value
Light Level Low in Lux*

*Light Level = Light Level High * 256 + Light
Level Low*

Motion:

*DALI 180 Query Scene 4 Value
Motion Status:
0 ... no motion
1 ... motion detected*

2 ... motion has been detected, delay running

General Settings

In general settings the operating mode can be changed and a DALI address can be assigned to the device. This DALI address can be used for querying sensor values.

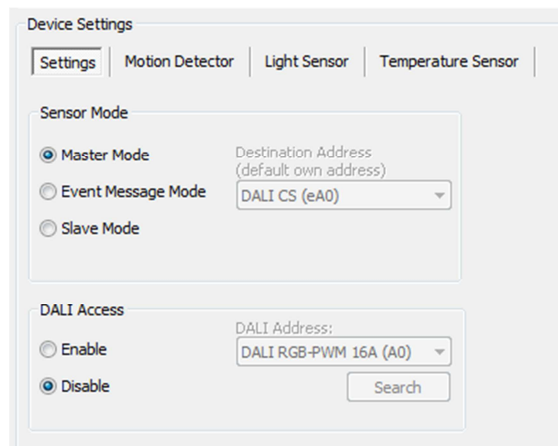

Up from firmware version 4.3 the following operating modes are supported:

Master Mode (Default)

In this operating mode the DALI CS acts as control device and sends event-based DALI-commands to DALI control gear as defined in the settings.

Event Message Mode

In this mode the proprietary synch-commands of the motion sensor can be redirected to any given address. Control Gear are not controlled directly, event messages can be evaluated by a central control unit. Light and temperature values can be queried.

Slave Mode

The DALI CS does not send out any commands. It only answers to queries.

Switching between operating modes:

Cmd225 Set DTR As Operating Mode

Cmd226 Query Operating Mode

- 0 ... *slave mode*
- 1 ... *master mode*
- 2 ... *event message mode*

DALI Instruction Set

The DALI CS operates as control device on the DALI-line and transmits the predefined DALI-commands event-based to the effective range defined.

For the synchronisation of several sensors for the same effective range proprietary command extensions are used.

Additional Information and Equipment

DALI-Cockpit – free configuration tool from Lunatone for DALI systems
<http://lunatone.at/de/dali-systeme/software/>

Lunatone DALI products
<http://www.lunatone.at/de/>

Lunatone datasheets and manuals
<http://lunatone.at/de/downloads/>

Contact

Technical Support: support@lunatone.com

Requests: sales@lunatone.com

www.lunatone.com

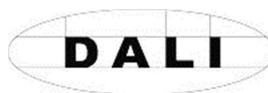

Disclaimer

Subject to change. Information provided without guarantee. The datasheet refers to the current delivery.

The function in installations with other devices must be tested for compatibility in advance.