

458/DIM8 8-Channel Dimmer Module

The 458/DIM8 is an 8-channel digital thyristor dimmer module, capable of leading-edge dimming of resistive and inductive loads. It has both a DALI and an S-DIM/DMX interface, and therefore can be fully integrated into a Digidim or an Imagine router system. It can also be used on the TouchPanel, or used on standalone DALI or Digidim systems.

The module has 8 channels rated at 10 A, with a total current capacity of 48 A, which can be configured as 8 x 6 A channels or 4x10 A channels.

The front of the module is equipped with an LCD display and keypad to set basic configuration parameters and provide basic control of channel and output levels.

The module is easily fitted to a Digidim 458Mx mechanical chassis, in which each load channel is protected by an individual MCB.

Note: Digidim control modules are supplied separately from the 458Mx mechanical chassis: suitable chassis are ordered separately.

Key Features

- Easily attached to a 458Mx chassis and connected to the mains supply for quick installation.
- LCD display screen and a 5-button keypad for monitoring, configuration and manual control.
- Auxiliary power supply can be used to power one TouchPanel.
- Built-in Digidim power supply, which can be used to power DALI systems, if required.

Options Module

There is an internal connection for an options module, which is sold separately.

The options module is used to convert 4 channels into either:

- 1 - 10 V → sink, 50 ballasts drive
- DSI (Digital Signal Interface) → 10 ballasts drive
- PWM (Pulse Width Modulation) → 10 ballasts drive
- DALI broadcast → 10 ballasts drive

Installation Notes

This involves removing the cover from the chassis. Do NOT connect DALI and S-DIM or DMX at the same time. Refer to the 458/DIM8 Installation Guide and 458Mx Chassis Installation Guide for details.



LCD Display



Installation

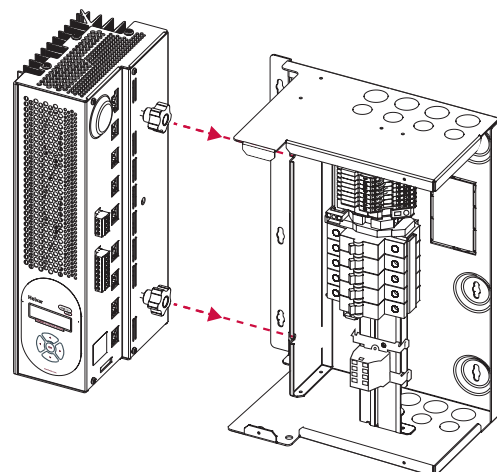

Technical Data

Connections

| | |
|------------------|---|
| DALI: | 0.5 mm ² - 1.5 mm ² (max. 300 m @ 1.5 mm ²) |
| S-DIM/DMX | 0.22 mm ² - 1.5 mm ² low loss RS485 Type (multi-stranded, twisted and shielded) |
| Override | 0.5 mm ² to 1.5 mm ² (screened and twisted) |

Power

| | |
|---------------------------|---|
| Mains supply: | 85 VAC to 264 VAC, 45 - 65 Hz |
| Power consumption: | 1.3 W (no DALI or TouchPanel PSUs used) |

Supply

| | |
|---------------------------|---|
| Supply current: | 48 A (max) |
| Nominal load: | 8x6 A or 4x10 A loads (max 48 A combined) |
| DALI supply: | 250 mA (max), 16 VDC (nominal) |
| TouchPanel supply: | 250 mA (max), 16 VDC (nominal) |

Protection

| | |
|-------------------------------|---|
| Electrical protection: | 6 A MCB and PTC for control board (MCB type C 10 kA). See 458Mx installation guide. |
| Thermal protection: | Control board – resettable fuse, power devices – thermal sensing |

Conformity and Standards

| | |
|-----------------------------|---|
| EMC Emission: | EN 55015 |
| Immunity: | EN 61547 |
| Safety: | EN 60950 |
| Isolation: | 4 kV |
| IP rating: | IP 20 |
| DALI data transfer: | According to DALI standard IEC60929, with Helvar extensions |
| S-DIM data transfer: | Helvar protocol (RS485, 115 kbps) |
| DMX data transfer: | DMX512-A protocol |
| Environmental: | Complies with WEEE and RoHS directives |

Installation

| | |
|------------------|--|
| Mounting: | Attached to 458M1, 458M2, or 458M3 chassis |
|------------------|--|

Mechanical Data

| | |
|--------------------|-----------------------------|
| Dimensions: | See diagram |
| Weight: | 6.2 kg |
| Housing: | Powder coated steel (black) |
| Heatsink: | Anodised aluminium |

Operating and Storage Conditions

| | |
|---------------------------|-------------------------|
| Ambient Temp: | 0°C to 40°C |
| Storage Temp: | -10°C to 70°C |
| Relative Humidity: | Max 90%, non-condensing |

Connections

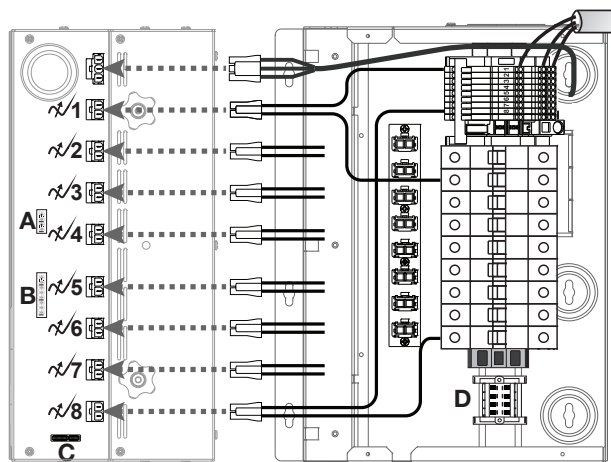

A: DALI supply
B: TouchPanel supply, OVR, S-DIM/DMX
C: Options module socket
D: S-DIM/DMX cable loom

Dimensions

Dimensions in mm

