

Digital DALI electronic ballasts for compact fluorescent lamps



18 - 42 W 220-240 V, 50-60 Hz

- Digital DALI control
- Switch-Control
- Stand-by consumption 0.3 W
- Dimming range 3-100 %
- Multilamp operation
- Single and twin lamp operation



A1 BAT

3

Lamp type	Wattage	No. of lamps	Ballast	EEL	Dimensions	Connection	Weight	Circuit power	Mains current	Lamp power
						(p.35)	(g)	(W)	(A)	(W)
TC-L/ TC-F	18	1	EL1/2x18/24iDim-c	A1 BAT	123x79x28	5	155	18	0.09	16
	18	2	EL1/2x18/24iDim-c	A1 BAT	123x79x28	6	155	35.5	0.16	16
	24	1	EL1/2x18/24iDim-c	A1 BAT	123x79x28	5	155	26	0.12	22
	24	2	EL1/2x18/24iDim-c	A1 BAT	123x79x28	6	155	50	0.23	22
T5c	22	1	EL1/2x18/24iDim-c	A1 BAT	123x79x28	5	155	26	0.12	22
	40	1	EL1/2x18/24iDim-c	A1 BAT	123x79x28	5	155	44.5	0.20	40
TC-DE/ TC-TE	18	1	EL1/2x18iDim-c	A1 BAT	123x79x28	5	155	20	0.09	16.5
	18	2	EL1/2x18iDim-c	A1 BAT	123x79x28	6	155	38	0.17	16.5
	26	1	EL1/2x26-42iDim-c	A1 BAT	123x79x28	5	155	28	0.13	23
	26	2	EL1/2x26-42iDim-c	A1 BAT	123x79x28	6	155	56	0.25	23.5
	26	2	EL2x26-42iDim-c	A1 BAT	123x79x28	7	176	56	0.25	25
	32	1	EL1/2x26-42iDim-c	A1 BAT	123x79x28	5	155	35	0.16	31
	32	2	EL2x26-42iDim-c	A1 BAT	123x79x28	7	176	70.5	0.32	32
	42	1	EL1/2x26-42iDim-c	A1 BAT	123x79x28	5	155	46	0.2	41.5
	42	2	EL2x26-42iDim-c	A1 BAT	123x79x28	7	176	93	0.42	43
	57	1	EL1/2x26-42iDim-c ¹⁾²⁾	A1 BAT	123x79x28	5	155	61	0.27	56

Note: See pages 35 - 37 for connection diagrams and additional characteristics.

1) Tested and recommended by Helvar, not ENEC approved

2) $U_{IN} > 220 V, T_a > 18 °C$

Dimensions

Length 'a' (mm)	123.0
Width 'b' (mm)	79.0
Height 'c' (mm)	28.0
'd' (mm)	100.5
'e' (mm)	65.0
'f' (mm)	111.0
'g' (mm)	25.5

Delivery information

Ballast	Unit package		Transportation package		
	Minimum delivery amount	Carton Box	Pallet 820 x 1280 (pcs.)	Pallet weight (kg)	Pallet height (cm)
EL-iDim-c	10	40	800	148	48

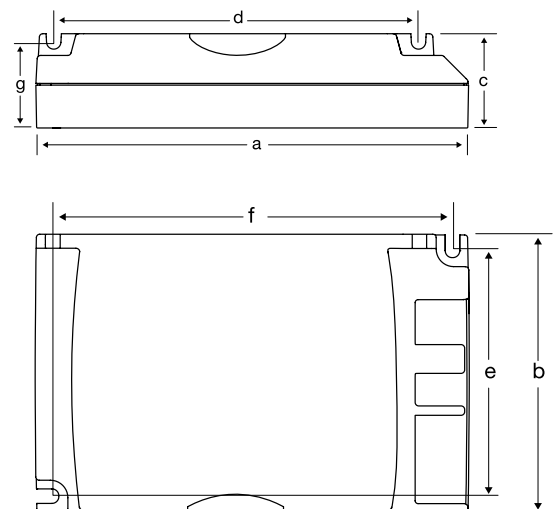

Right to use German patent DE19757295 of Tridonic Atco

Connection diagrams

EL-iDim

NOTE: All wiring to the connectors marked with a red dot (hot wires) should be as short as possible.

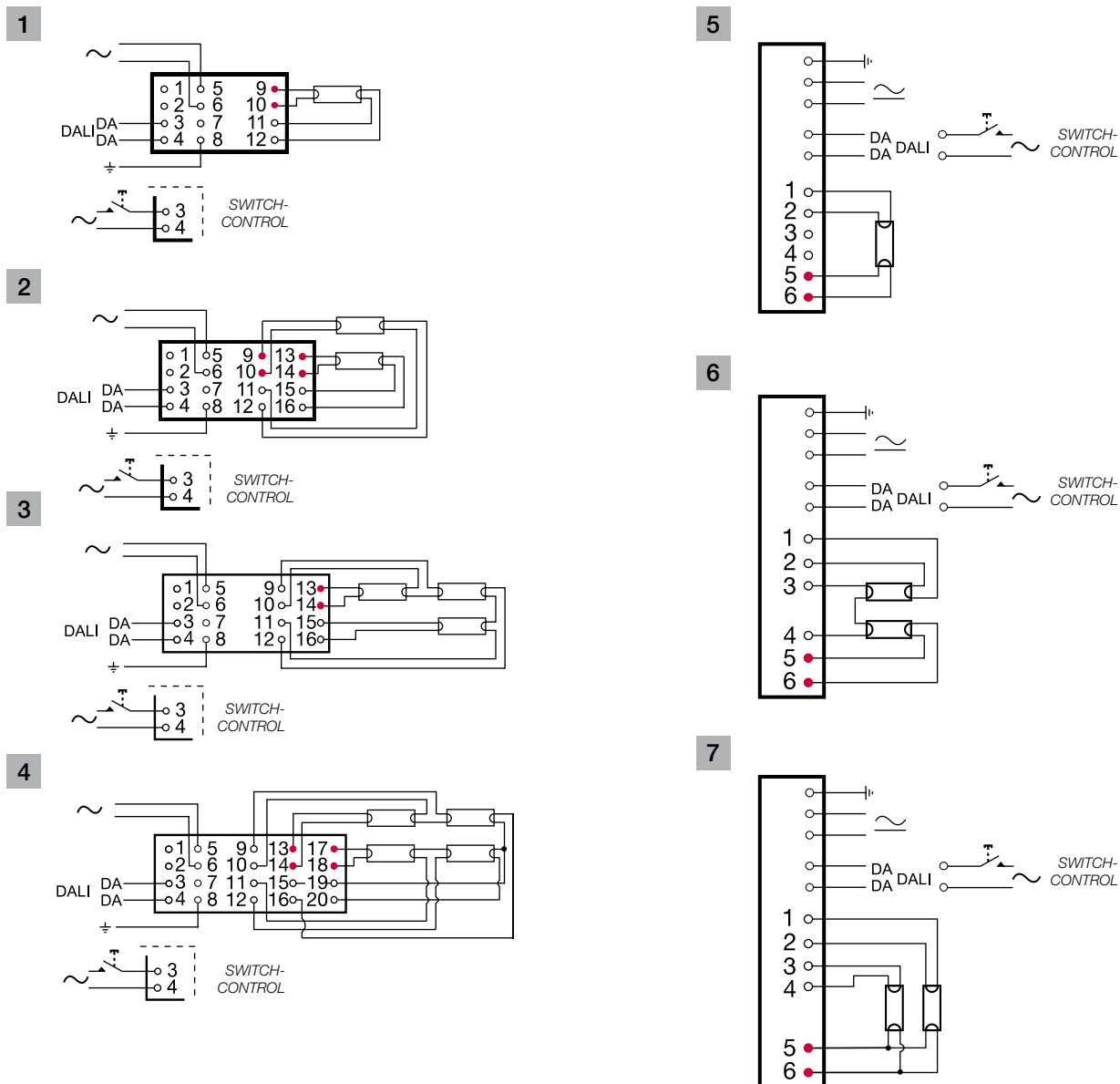

1	EL1x ...iDim
2	EL2x ...iDim
3	EL3x ...iDim
4	EL4x ...iDim
5	EL1/2x...iDim-c
6	EL1/2x...iDim-c
7	EL2x...iDim-c

Characteristics

	EL-iDim	EL-iDim-c
Max.temperature at t_c point	75 °C ³⁾	75 °C
Ambient temperature range	+10...+50 °C ^{1) 5) 6)}	+10...+50 °C ⁵⁾
Storage temperature range	-40...+80 °C	-40...+80 °C
Maximum relative humidity	no condensation	no condensation
Number of starts per lamp	> 50 000	> 50 000
AC Range	198-264 VAC	198-264 VAC
DC range (starting voltage >198VDC)	176-280 VDC	176-280 VDC
Over voltage duration	320 VAC, 1h	320 VAC, 1h
EBLF (Emergency Ballast Lumen Factor)	N/A	> 0.5 ⁷⁾
BLF (Ballast Lumen Factor), steady state	~1	~1
Programmable light output for DC operation	yes	yes
Power factor (at maximum), typical	0.96	0.96
Earth leakage current	< 0.4 mA	< 0.4 mA
Maximum working voltage (Uout)	400 V	400 V
Lifetime (90 % survival)	50 000 h, at t_c	50 000 h, at t_c
Max length of ballast to lamp wiring	1.5 m / 2 m (hot / cold) ²⁾⁴⁾	1 m / 1 m (hot / cold) ⁴⁾
Ignition time, typical	1.0 s	1.0 s ⁸⁾
Type of starting	Preheat (warm start)	Preheat (warm start)

1) To ensure stable operation of TC-L lamps in ambient temperatures below 18 °C it is not recommended to dim the light level below 3 %

2) For TC-L lamps 1 m / 2 m (hot/cold lamp wires)

3) For EL 3x14iDim, $t_c = 65$ °C

4) Minimise lamp wire length variations in order to avoid imbalance in light output.

5) When using EL3x14iDim, EL4x14iDim and EL1/2x18/24iDim-c ballasts in ambient temperatures below 15 °C it is not recommended to dim the light level below 10 % to ensure stable lamp operation.

6) For EL2x80iDim, it is not recommended to dim the light below 5 % in temperatures below 15 °C

7) EL2x26-42iDim-c; EBLF > 0,3

8) EL1/2x18/24iDim-c ignition time = 1.4 s

Standards

	EL-iDim	EL-iDim-c
General and safety requirements EN61347-2-3	●	●
Additional safety requirements for AC/DC supplied ballasts acc. to EN61347-2-3 Annex J	●	●
Performance requirements EN60929	●	●
Preheat starting	●	●
Lamp life acc. to EN60081 / EN60901 *)	●	●
Mains current harmonics, acc. to EN61000-3-2	●	●
Radio Frequency Interference, acc. to EN55015	●	●
Immunity standard, acc.to EN61547	●	●
Vibration test EN60068-2-64 test Fh	●	●
Bump test EN60068-2-29 test Eb	●	●
Thermal protection class EN61347, C5e	●	●
Tested and proven compatible with DALI V1 (IEC62386, 2009)	●	●

* EN 60081 for T5 & T8 fluorescent lamps, EN 60901 for compact fluorescent lamps

Switch-Control Information, EL-iDim / EL-iDim-c ballasts

Switch-Control provides ON/OFF switching and UP/DOWN dimming functionality from one or more simple switches.

Switch-Control and DALI can not be connected to the iDim ballast at the same time.

Suitable switch:

- Automatic return type
- Mains rated

Connection:

- EL-iDim ballasts: To the DALI input
- Wire length: 25 m maximum. diagram A
25 - 200 m, use a capacitor (1 μ F, 275 V) diagram B
- Ballasts per switch: 50 (observe above)
- Ensure all ballasts and associated switches are connected to the same mains phase

Operation:

- Switch off: Short push of the switch (< 0.4 second)
- Switch on: Short push of the switch (< 0.4 second)
- EL-iDim ballasts will switch on to the last set level
- Dimming: Long push of the switch (> 0.5 second)
 - If lamps are off, the ballast dims up from minimum
 - If lamps are on, the ballast dims in the opposite direction to previously
 - The first dimming direction is dimming down

Correction of out of sequence operation:

- Switch the mains supply off and on, or...
- Long push (until all lamps are on), then a short push (all lamps off), then switch on

Compatibility:

Some ballasts manufacturers have functionality similar to Helvar Switch-Control. These methods are NOT COMPATIBLE with each other.

Connection

- To the DALI input

A) 0-25 m

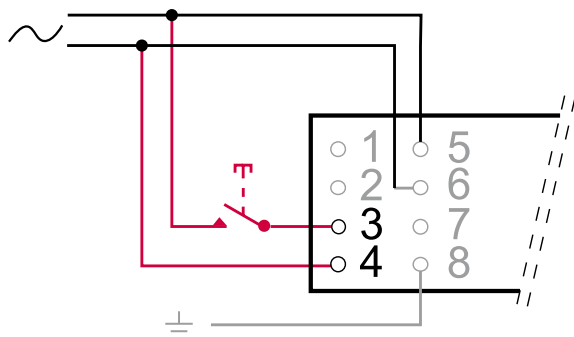

B) 25-200 m

