





**DOL starter, 380 V 400 V 415 V: 3 kW, I<sub>q</sub>= 100 kA, I<sub>r</sub>= 3 - 12 A, 230 V 50 Hz, 240 V 60 Hz, AC voltage**

**Part no. MSC-DE-12-M7(230V50HZ)**  
**Catalog No. 121739**  
**Alternate Catalog XTSE012B007BFNL**  
**No.**  
**EL-Nummer 4315118**  
**(Norway)**

**Delivery program**

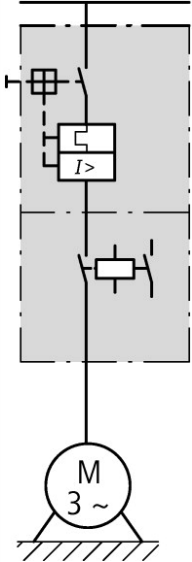
Basic function				DOL starters (complete devices)
Basic device				MSC
				
Notes				Also suitable for motors with efficiency class IE3. IE3-ready devices are identified by the logo on their packaging.
Connection to SmartWire-DT				no
<b>Motor ratings</b>				
Motor rating				
AC-3				
380 V 400 V 415 V	P	kW		3
Rated operational current				
AC-3				
380 V 400 V 415 V	I <sub>e</sub>	A		6.6
Rated short-circuit current 380 - 415 V	I <sub>q</sub>	kA		100
<b>Setting range</b>				
Setting range of overload releases	I <sub>r</sub>	A		3 - 12
				
Coordination				Type of coordination "1"
Contact sequence				
Actuating voltage				230 V 50 Hz, 240 V 60 Hz AC voltage
<b>Motor-protective circuit-breakers</b> PKE12/XTU-12				
Contactor DILM7-10(...)				
<b>DOL starter wiring set</b> Mechanical connection element and electrical electric contact module PKZM0-XDM12				

## Notes

The DOL starters (complete units) consist of a PKE motor protective circuit breaker and a DILM contactor.

With the adapter-less top-hat rail mounting of starters up to 15 A, only the motor protective circuit breaker on the top-hat rail requires an adapter.

The contactors are provided with mechanical support via a mechanical connection element.

Control wire guide with max. 6 conductors up to 2.5 mm external diameter or 4 conductors up to 3.5 mm external diameter.

The connection of the main circuit between PKE and contactor is established with electrical contact modules.

When using DILA-XHIT... auxiliary contacts with MSC-DE-... DOL starters, the plug-in electrical connectors can be removed without removing the front-mounted auxiliary contact.

Cannot be combined with NHI-E...PKZ0-C.

The MSC-DEA... DOL starters are prepared for communication via SmartWire-DT. For this, the PKE-SWD-32 communication module must be added.

Motor output/rated motor current	Rated motor current		
Motor rating	AC-3		
	220 V	380 V	415 V
	230 V	400 V	
	240 V		
	$I_q = 100 \text{ kA}$	$I_q = 100 \text{ kA}$	$I_q = 50 \text{ kA}$
P	I	I	I
kW	A	A	A
0.75	3.2	-	-
1.1	4.6	-	-
1.5	6.3	3.6	3.6
2.2	-	5	5
3	-	6.6	6.6

## Technical data

### General

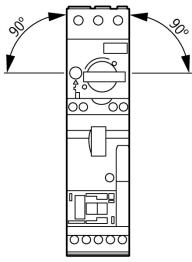
Standards		IEC/EN 60947-4-1, VDE 0660
Mounting position		

### Main conducting paths

Rated impulse withstand voltage	$U_{imp}$	V AC	6000
Overvoltage category/pollution degree			III/3
Rated operational voltage	$U_e$	V	230 - 415
Rated operational current			
Open, 3-pole: 50 – 60 Hz			
380 V 400 V	$I_e$	A	7
AC-4 cycle operation			
Minimum current flow times		ms	500 (Class 5) 700 (Class 10) 900 (Class 15) 1000 (Class 20)
Minimum cut-out periods		ms	500
Note		ms	In AC-4 cycle operation, going below the minimum current flow time can cause overheating of the load (motor). For all combinations with an SWD activation, you need not adhere to the minimum current flow times and minimum cut-out periods.

### Additional technical data

Motor protective circuit breaker PKZM0, PKE			PKZM0 motor-protective circuit-breakers, see motor-protective circuit-breakers/ PKZM0 product group DILM contactors, see contactor product group DILET timing relay, ETR, see contactors, electronic timing relays product group
DILM contactors			
Current heat loss			
Current heat loss at $I_e$ to AC-3/400 V		W	1.32
Power consumption of the coil in a cold state and $1.0 \times U_S$			
Dual-voltage coil 50 Hz	Sealing	W	1.4

### Rating data for approved types

Short Circuit Current Rating		SCCR
------------------------------	--	------

Basic Rating			
SCCR	kA		10
max. Fuse	A		200
max. CB	A		150
480 V High Fault			
SCCR (fuse)	kA		100
max. Fuse	A		125 Class J/CC
SCCR (CB)	kA		65
max. CB	A		100
600 V High Fault			
SCCR (fuse)	kA		100
max. Fuse	A		125 Class J/CC

## Design verification as per IEC/EN 61439

Technical data for design verification			
Rated operational current for specified heat dissipation	$I_n$	A	7
Heat dissipation per pole, current-dependent	$P_{vid}$	W	0.4
Equipment heat dissipation, current-dependent	$P_{vid}$	W	1.3
Static heat dissipation, non-current-dependent	$P_{vs}$	W	1.4
Heat dissipation capacity	$P_{diss}$	W	0
Operating ambient temperature min.		°C	-25
Operating ambient temperature max.		°C	55
IEC/EN 61439 design verification			
10.2 Strength of materials and parts			
10.2.2 Corrosion resistance			Meets the product standard's requirements.
10.2.3.1 Verification of thermal stability of enclosures			Meets the product standard's requirements.
10.2.3.2 Verification of resistance of insulating materials to normal heat			Meets the product standard's requirements.
10.2.3.3 Verification of resistance of insulating materials to abnormal heat and fire due to internal electric effects			Meets the product standard's requirements.
10.2.4 Resistance to ultra-violet (UV) radiation			Meets the product standard's requirements.
10.2.5 Lifting			Does not apply, since the entire switchgear needs to be evaluated.
10.2.6 Mechanical impact			Does not apply, since the entire switchgear needs to be evaluated.
10.2.7 Inscriptions			Meets the product standard's requirements.
10.3 Degree of protection of ASSEMBLIES			Does not apply, since the entire switchgear needs to be evaluated.
10.4 Clearances and creepage distances			Meets the product standard's requirements.
10.5 Protection against electric shock			Does not apply, since the entire switchgear needs to be evaluated.
10.6 Incorporation of switching devices and components			Does not apply, since the entire switchgear needs to be evaluated.
10.7 Internal electrical circuits and connections			Is the panel builder's responsibility.
10.8 Connections for external conductors			Is the panel builder's responsibility.
10.9 Insulation properties			
10.9.2 Power-frequency electric strength			Is the panel builder's responsibility.
10.9.3 Impulse withstand voltage			Is the panel builder's responsibility.
10.9.4 Testing of enclosures made of insulating material			Is the panel builder's responsibility.
10.10 Temperature rise			The panel builder is responsible for the temperature rise calculation. Eaton will provide heat dissipation data for the devices.
10.11 Short-circuit rating			Is the panel builder's responsibility. The specifications for the switchgear must be observed.
10.12 Electromagnetic compatibility			Is the panel builder's responsibility. The specifications for the switchgear must be observed.
10.13 Mechanical function			The device meets the requirements, provided the information in the instruction leaflet (IL) is observed.

## Technical data ETIM 7.0

Low-voltage industrial components (EG000017) / Motor starter/Motor starter combination (EC001037)			
Electric engineering, automation, process control engineering / Low-voltage switch technology / Load breakout, motor breakout / Motor starter combination (ecl@ss10.0.1-27-37-09-05 [AJZ718013])			
Kind of motor starter			Direct starter

With short-circuit release		Yes
Rated control supply voltage Us at AC 50HZ	V	230 - 230
Rated control supply voltage Us at AC 60HZ	V	0 - 0
Rated control supply voltage Us at DC	V	0 - 0
Voltage type for actuating		AC
Rated operation power at AC-3, 230 V, 3-phase	kW	1.5
Rated operation power at AC-3, 400 V	kW	3
Rated power, 460 V, 60 Hz, 3-phase	kW	0
Rated power, 575 V, 60 Hz, 3-phase	kW	0
Rated operation current Ie	A	6.6
Rated operation current at AC-3, 400 V	A	7
Overload release current setting	A	3 - 12
Rated conditional short-circuit current, type 1, 480 Y/277 V	A	0
Rated conditional short-circuit current, type 1, 600 Y/347 V	A	0
Rated conditional short-circuit current, type 2, 230 V	A	0
Rated conditional short-circuit current, type 2, 400 V	A	0
Number of auxiliary contacts as normally open contact		1
Number of auxiliary contacts as normally closed contact		0
Ambient temperature, upper operating limit	°C	60
Temperature compensated overload protection		Yes
Release class		Adjustable
Type of electrical connection of main circuit		Screw connection
Type of electrical connection for auxiliary- and control current circuit		Screw connection
Rail mounting possible		Yes
With transformer		No
Number of command positions		0
Suitable for emergency stop		No
Coordination class according to IEC 60947-4-3		Class 1
Number of indicator lights		0
External reset possible		No
With fuse		No
Degree of protection (IP)		IP20
Degree of protection (NEMA)		Other
Supporting protocol for TCP/IP		No
Supporting protocol for PROFIBUS		No
Supporting protocol for CAN		No
Supporting protocol for INTERBUS		No
Supporting protocol for ASI		No
Supporting protocol for MODBUS		No
Supporting protocol for Data-Highway		No
Supporting protocol for DeviceNet		No
Supporting protocol for SUCONET		No
Supporting protocol for LON		No
Supporting protocol for PROFINET IO		No
Supporting protocol for PROFINET CBA		No
Supporting protocol for SERCOS		No
Supporting protocol for Foundation Fieldbus		No
Supporting protocol for EtherNet/IP		No
Supporting protocol for AS-Interface Safety at Work		No
Supporting protocol for DeviceNet Safety		No
Supporting protocol for INTERBUS-Safety		No
Supporting protocol for PROFIsafe		No
Supporting protocol for SafetyBUS p		No
Supporting protocol for other bus systems		No
Width	mm	45

Height	mm	198
Depth	mm	102

## Dimensions

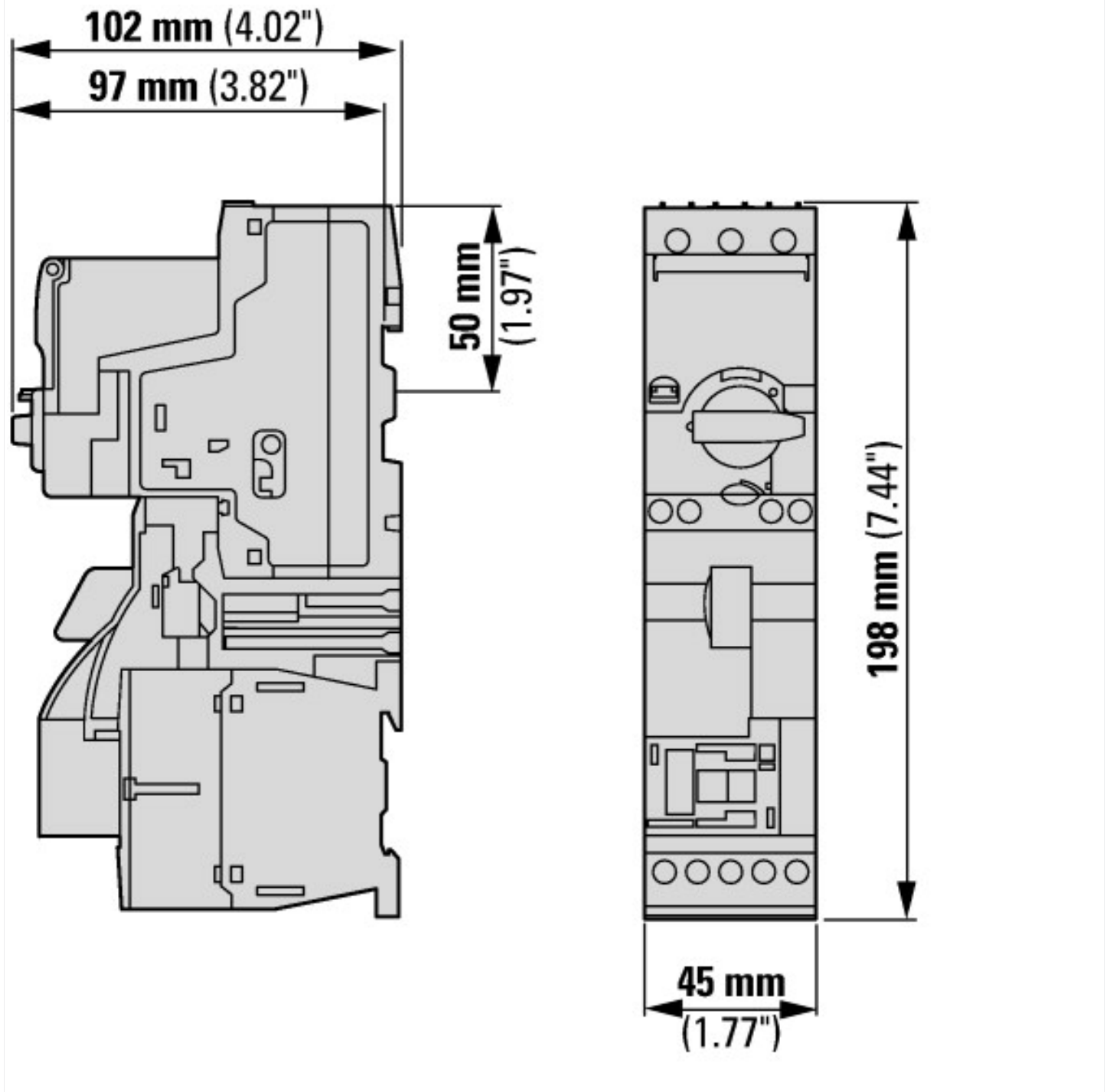

## Assets (links)

### Declaration of CE Conformity

00002889

### Instruction Leaflets

IL034038ZU2018\_06