

**Product selected: INSTAR 90 HALOGEN 50 ( ) WH**

Downlights that offer a very high light comfort level, due to a deep lamp position and faceted chrome finish reflector. Taking QT10 and QT12 lamps up to 75w, Instar Halogen fittings are IP44-rated and come with a safety glass which also protects the reflector and lamp against dust and dirt

**Product Image**



**Product Line Drawing**

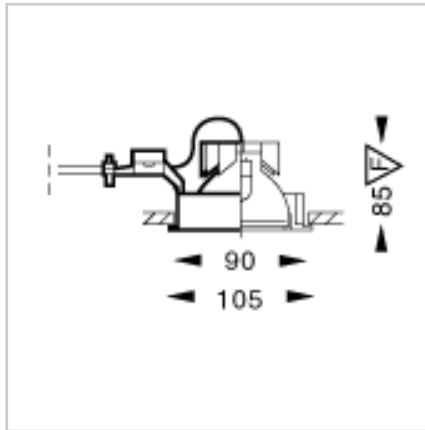

**Lamp(s)**

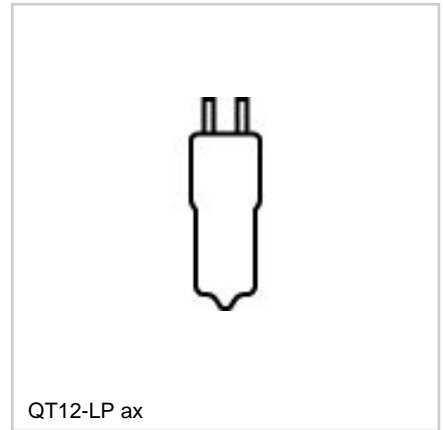

**Light Distribution**

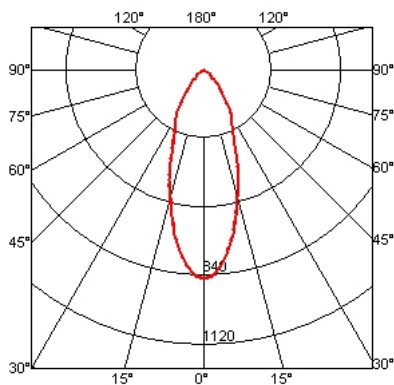

**Product Details**

<b>Order code</b>	3021850
<b>Item name</b>	INSTAR 90 HALOGEN 50 ( ) WH
<b>Mounting</b>	Ceiling recessed
<b>Place of use</b>	Interior
<b>Colour</b>	White
<b>Cutout shape</b>	Round
<b>Cutout diameter (mm)</b>	90
<b>Recessed depth</b>	85
<b>Diameter (mm)</b>	105
<b>Weight (kg)</b>	0.18
<b>Distribution type</b>	Direct - Symmetric
<b>Beam</b>	Flood
<b>Optical controller material</b>	Safety glass cover
<b>Lamps description</b>	1 x QT-ax12 50W GY6.35
<b>Number of lamps</b>	1
<b>Lamp included</b>	No
<b>Number of heads</b>	1
<b>Emergency</b>	Without
<b>Transformer availability</b>	Separate item
<b>Transformer mounting</b>	Remote
<b>Transformer type</b>	Electronic
<b>Voltage (V)</b>	12